



Type SCC

**Swing Check valves
Cast Steel
Pressure Seal
Buttweld End
Class 900, 1500 & 2500
50 - 400 mm
(2" - 16")**

Applications

- Power stations, general industry, process engineering
- For water, steam, gas, oil & other non-aggressive media
- Further applications on request

Operating Data

- Pressure up to 431 bar (6250 psi)
- Temperature up to +593°C/1100°F
- Pressure-temperature ratings as per ASME B 16.34, Special class

Materials

ANSI Special class (as per ASME B 16.34)

- # 900/1500/2500 - A 216 WCB from 0°C to 425°C
- # 900/1500/2500 - A 217 WC9/WC6 from 0°C to 593°C
- # Other materials on request

Design

- As per ASME B 16.34
- Pressure Seal Bonnet Design
- Stellite hard-faced Seats & Disc surface
- Graphite gaskets

Remarks

Forged Valves leaflet no.	: 7240.1/5-10
Pressure Seal Gate Valve leaflet no.	: 7241.2/7-10
Pressure Seal Globe Valve leaflet no.	: 7242.2/6-10
Cast Steel Gate Valve leaflet no.	: 7244.2/5-10
Cast Steel Globe Valve leaflet no.	: 7245.2/5-10
Cast Steel Check Valve leaflet no.	: 7246.2/5-10
Operating instructions no.	: 0500.80/03-18 G3

On all enquiries / orders please specify :

- | | |
|--------------------------------|-----------------------------------------|
| 1. Type | 8. Material of construction |
| 2. ANSI Pressure class | 9. Flow medium |
| 3. Size | 10. Flow rate Min. / Max. |
| 4. Design pressure/temperature | 11. Type of end connection |
| 5. Operating pressure | 12. Pipe schedule ID / OD |
| 6. Operating temperature | 13. Variants |
| 7. Differential pressure | 14. Leaflet number |
| | 15. Valve data sheet
(if applicable) |

When ordering spares, indicate valve serial number.

Product features to our customer benefit

Inside Hinge Pin
 Body Seat Ring St6 (HF)
 Disc Seats St6 (HF)
 Seal Weld
 Hinge Bracket
 Disc Carrier
 Body Special class to ASME B 16.34

- Valves meets ASME 16.34 Special Class requirements
- Inside hinge pin mounted design - no leakage path to atmosphere
- Self aligning free floating and non-rotating disc
- Designed to open at low differential pressures

Thrust ring (Segmental)
 Spacer ring
 Graphite gasket
 Bonnet Special class to ASME B16.34

Pressure seal

- Die-moulded graphite gasket
- Segmental ring arrangement with knock out holes provides for easy disassembly

Disc
 Seal weld
 Body

Flow Seal

- Fully stellited, body & Disc seat
- Seat rings - seal welded to body
- Lapped Seat & Disc faces for leak tightness
- Streamlined flow path ensures minimum pressure drop

Hinge pin
 Seat ring
 Disc Carrier
 Disc
 Cotter pin

Disc Design

- Self aligning disc ensures perfect seating
- Designed to open at low differential pressure

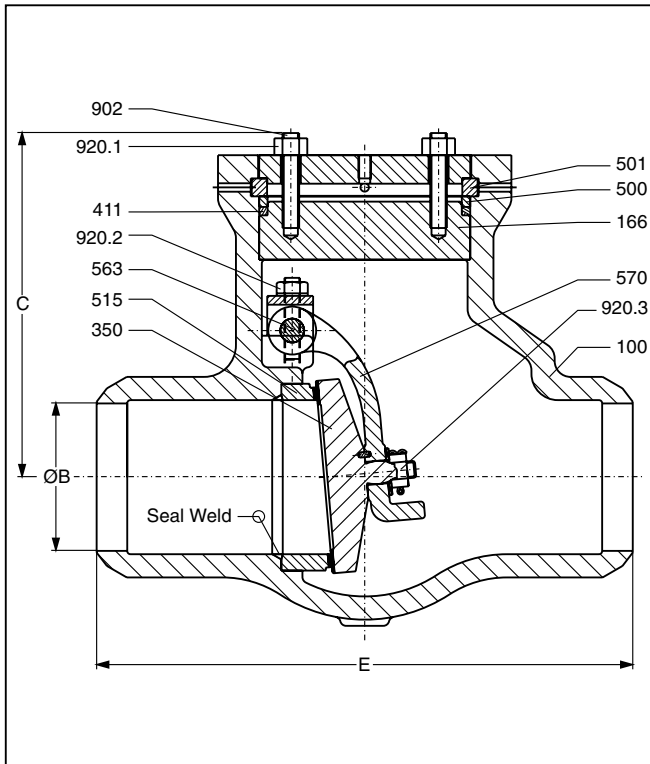

Dimensions in mm

Class 900

	50	80	100	150	200	250	300
E	215.9	304.8	355.6	508.0	660.4	787.4	914.4
ØB*	49.2	73.5	92.0	140.0	182.5	230.0	273.0
C_(max)	180.0	240.0	290.0	320.0	375.0	440.0	500.0

* Schedule 80 up to 3". Schedule 120 for 4" and above.
Alternate schedule on request.

Class 1500

	50	80	100	150	200	250	300	350	400
E	215.9	304.8	406.4	558.8	711.2	863.6	990.6	1066.8	1194.0
ØB*	43.0	66.5	87.5	132.0	173.0	216.0	257.0	284.0	325.5
C_(max)	230.0	270.0	315.0	400.0	440.0	475.0	630.0	700.0	770.0

* Schedule 160. Alternate schedule on request.

Class 2500

	50	80	100	150	200	250	300
E	279.4	368.3	457.2	609.4	762.0	914.4	1041.4
ØB*	38.0	58.5	80.0	124.5	173.0	216.0	257.0
C_(max)	225.0	270.0	315.0	390.0	425.0	500.0	630.0

* Schedule XXS up to 6". Schedule 160 for 8" and above.
Alternate schedule on request.

Design Specifications

- General valve design & pressure, temperature rating : ASME B 16.34 Special class
- Butt weld end design : ASME B 16.25
- End to end dimension : ASME B 16.10
- Testing : API 598

Materials

Part No.	Description	Material		
100	Body	A 216-WCB	A 217-WC9	A 217-WC6
166	Bonnet	A 216-WCB	A 217-WC9	A 217-WC6
350	Disc	A 216-WCB+ST6	A 217-WC9+ST6	A 217-WC9+ST6
411	Gasket	Graphite	Graphite	Graphite
500	Spacer Ring	A 217-CA15/A 182-F22	A 217-CA15/A 182-F22	A 217-CA15/A 182-F22
501	Trust Ring	A 182-F22/A 217-WC9	A 182-F22/A 217-WC9	A 182-F22/ A 217-WC9
515	Seat Ring	A 105+ST6	A 182-F22+ST6	A 182-F22+ST6
563	Hinge Pin	A 276-410/A 479-410/2	A 276-410/A 479-410/2	A 276-410/A 479-410/2
570	Disc Carrier	A 216-WCB	A 217-WC9	A 217-WC9
902	Stud	A 193-B7	A 193-B16	A 193-B16
920.1/2/3	Hex. Nut	A 194-2H	A 194-4 / 7	A 194-4 / 7

Test Specifications

Test / Test pressure	#900		#1500		#2500		Testing medium
	kg/cm ²	psi	kg/cm ²	psi	kg/cm ²	psi	
Shell	238	3375	395	5625	659	9375	Water
Seat	174	2475	290	4125	484	6875	

**Rating for Group 1.1 Material : A 216 Gr. WCB⁽¹⁾
Special Class**

Temperature		# 900		# 1500		# 2500	
°F	°C	psi	kg/cm ²	psi	kg/cm ²	psi	kg/cm ²
-20 to 100	-17 to 38	2250	158.1	3750	263.5	6250	439.2
200	93.3	2250	158.1	3750	263.5	6250	439.2
300	148.9	2220	156.0	3700	260.0	6170	433.6
400	204.4	2200	154.6	3665	257.6	6105	429.0
500	260.0	2200	154.6	3665	257.6	6105	429.0
600	315.6	2200	154.6	3665	257.6	6105	429.0
650	343.3	2145	150.7	3575	251.2	5960	418.8
700	371.1	2075	145.8	3455	242.8	5760	404.8
750	398.9	1905	133.9	3170	222.8	5285	371.4
800	426.7	1545	108.6	2570	180.6	4285	301.1
850	454.4	1195	84.0	1995	140.2	3320	233.3
900	482.2	860	60.4	1435	100.8	2395	168.3
950	510.0	515	36.2	855	60.1	1430	100.5
1000	537.8	320	22.5	535	37.6	895	62.9

1) Permissible, but not recommended for prolonged use above 800°F

**Rating for Group 1.9 Material : A 217 Gr. WC6⁽¹⁾⁽²⁾
Special Class**

Temperature		# 900		# 1500		# 2500	
°F	°C	psi	kg/cm ²	psi	kg/cm ²	psi	kg/cm ²
-20 to 100	-17 to 38	2250	158.1	3750	263.5	6250	439.2
200	93.3	2250	158.1	3750	263.5	6250	439.2
300	148.9	2250	158.1	3750	263.5	6250	439.2
400	204.4	2250	158.1	3750	263.5	6250	439.2
500	260.0	2250	158.1	3750	263.5	6250	439.2
600	315.6	2250	158.1	3750	263.5	6250	439.2
650	343.3	2250	158.1	3750	263.5	6250	439.2
700	371.1	2200	154.6	3665	257.6	6110	429.4
750	398.9	2185	153.5	3645	256.1	6070	426.6
800	426.7	2160	151.8	3600	253.0	6000	421.6
850	454.4	2030	142.7	3385	237.9	5645	396.7
900	482.2	1760	123.7	2935	206.3	4895	344.0
950	510.0	1195	84.0	1995	140.2	3320	233.3
1000	537.8	810	56.9	1350	94.9	2250	158.1
1050	565.6	540	37.9	900	63.2	1500	105.4
1100	593.3	360	25.3	600	42.2	1000	70.3
1150	621.1	245	17.2	405	28.5	680	47.8
1200	648.9	155	10.9	255	17.9	430	30.2

1) Use Normalised and tempered material only.

2) Not to be used over 1100°F

**Rating for Group 1.3 Material : A 352 Gr. LCB⁽¹⁾
Special Class**

Temperature		# 900		# 1500		# 2500	
°F	°C	psi	kg/cm ²	psi	kg/cm ²	psi	kg/cm ²
-20 to 100	-17 to 38	2090	146.9	3480	244.6	5805	407.9
200	93.3	2090	146.9	3480	244.6	5805	407.9
300	148.9	2090	146.9	3480	244.6	5805	407.9
400	204.4	2090	146.9	3480	244.6	5805	407.9
500	260.0	2090	146.9	3480	244.6	5805	407.9
600	315.6	2090	146.9	3480	244.6	5805	407.9
650	343.3	2080	146.2	3470	243.9	5780	406.2
700	371.1	1985	139.5	3305	232.3	5510	387.2
750	398.9	1785	125.4	2980	209.4	4965	348.9
800	426.7	1465	103.0	2445	171.8	4070	286.0
850	454.4	1120	78.7	1865	131.1	3105	218.2
900	482.2	760	53.4	1265	88.9	2105	147.9
950	510.0	515	36.2	855	60.1	1430	100.5
1000	537.8	320	22.5	535	37.6	895	62.9

1) Not to be used over 650°F

**Rating for Group 1.10 Material : A 217 Gr. WC9⁽¹⁾⁽²⁾
Special Class**

Temperature		# 900		# 1500		# 2500	
°F	°C	psi	kg/cm ²	psi	kg/cm ²	psi	kg/cm ²
-20 to 100	-17 to 38	2250	158.1	3750	263.5	6250	439.2
200	93.3	2250	158.1	3750	263.5	6250	439.2
300	148.9	2200	156.0	3695	259.7	6160	432.9
400	204.4	2185	153.5	3640	255.8	6065	426.2
500	260.0	2175	152.8	3620	254.4	6035	424.1
600	315.6	2165	152.1	3605	253.3	6010	422.3
650	343.3	2145	150.7	3580	251.6	5965	419.2
700	371.1	2120	149.0	3535	248.4	5895	414.3
750	398.9	2120	149.0	3535	248.4	5895	414.3
800	426.7	2120	149.0	3535	248.4	5895	414.3
850	454.4	2030	142.7	3385	237.9	5645	396.7
900	482.2	1800	126.5	3000	210.8	5000	351.4
950	510.0	1415	99.4	2360	165.8	3930	276.2
1000	537.8	1005	70.6	1670	117.4	2785	195.7
1050	565.6	655	46.0	1095	77.0	1820	127.9
1100	593.3	410	28.8	685	48.1	1145	80.5
1150	621.1	255	17.9	430	30.2	715	50.2
1200	648.9	155	10.9	255	17.9	430	30.2

1) Use Normalised and tempered material only.

2) Not to be used over 1100°F