



EN

**Please carefully read these operating instructions before use. · Do not discard.  
The operator shall be liable for any damage caused by installation or operating errors.  
The latest version of the operating instructions are available on our homepage.**

### Supplementary information



*Fig. 1: Please read!*

Read the following supplementary information in its entirety! Should you already know this information, you will benefit more from referring to the operating instructions.

The following are highlighted separately in the document:

- Enumerated lists
- ➔ Operating instructions
- ⇒ Outcome of the instructions

- see (reference)

### Information



*This provides important information relating to the correct operation of the unit or is intended to make your work easier.*

### Safety Information

Safety information is identified by pictograms - see "Safety Chapter".

# Table of contents

<b>1</b>	<b>Identity code</b> .....	<b>5</b>
<b>2</b>	<b>About this product</b> .....	<b>7</b>
<b>3</b>	<b>Safety chapter</b> .....	<b>8</b>
<b>4</b>	<b>Storage and transport</b> .....	<b>11</b>
<b>5</b>	<b>Overview of equipment</b> .....	<b>12</b>
<b>6</b>	<b>Functional description</b> .....	<b>13</b>
<b>7</b>	<b>Assembly and Installation</b> .....	<b>14</b>
	7.1 Assembly.....	14
	7.2 Installation, hydraulic.....	15
	7.3 Installation, electrical.....	16
	7.3.1 Current output.....	17
	7.3.2 Counter output.....	17
	7.3.3 Current output and counter output.....	20
	7.3.4 Output for controlled pump .....	20
<b>8</b>	<b>Set up</b> .....	<b>21</b>
	8.1 Operating unit.....	21
	8.1.1 LCD screen.....	21
	8.1.2 LEDs.....	21
	8.1.3 Control keys.....	21
	8.2 Check display variables.....	23
	8.3 Operating menu overview.....	25
	8.4 Changing to adjustment mode.....	26
	8.4.1 "Operation" main menu.....	26
	8.4.2 "Set-up" main menu.....	26
	8.4.3 "Calibration" main menu.....	31
	8.4.4 "Zero set" main menu.....	43
	8.4.5 "Info" main menu.....	44
	8.4.6 "Language" main menu.....	44
<b>9</b>	<b>Start up</b> .....	<b>45</b>
<b>10</b>	<b>Maintenance, repair and disposal</b> .....	<b>47</b>
	10.1 Maintenance.....	48
	10.2 Repairs.....	48
	10.3 Disposal.....	48
<b>11</b>	<b>Troubleshooting</b> .....	<b>49</b>
	11.1 DulcoFlow® error.....	50

---

## Table of contents

---

11.2	Pump error in connection with DulcoFlow®.....	51
11.3	All Other Faults.....	52
<b>12</b>	<b>Technical Data.....</b>	<b>53</b>
<b>13</b>	<b>Dimensions sheet.....</b>	<b>56</b>
<b>14</b>	<b>Factory settings.....</b>	<b>57</b>
<b>15</b>	<b>EC Declaration of Conformity.....</b>	<b>58</b>
<b>16</b>	<b>Decontamination declaration.....</b>	<b>59</b>
<b>17</b>	<b>Index.....</b>	<b>60</b>

# 1 Identity code

Product range flow meter DulcoFlow®		
DFMa	Type	For pump product ranges
	05	Beta, gamma/ L: 1000 - 0413/0713; gamma/ X: 1000 - 0414/0715 (with the exception of 0220); delta: 1608 - 1612
	08	Beta, gamma/ L: 1005/1605 - 0420 gamma/ X: 1604 - 0224 delta: 1020 - 0450 Sigma/ 1
		<b>Seal material</b>
	E	EPDM
	VAR- IOUS SET- TING S	FPM
	T	PTFE
		<b>Hydraulic connector</b>
	1	6/4 mm
	2	8/5 mm
	3	12/9 mm
		<b>Electrical connection</b>
	A	2 m European
	B	2 m Swiss
	CHLO RINE STOR AGE TANK	2 m Australian
	D	2 m USA
		<b>Signal output</b>

---

## Identity code

---

### Product range flow meter DulcoFlow®

					0	No output
					1	Current output
					2	Counter output
					3	Current and counter output
					4	Output for controlled pump
						<b>Design</b>
					0	With ProMinent® Logo
					2	Without ProMinent® Logo
						<b>Accessories</b>
					0	No accessories

---

## 2 About this product

The flow meter DulcoFlow® is intended for the measurement of pulsating volumetric flows in ProMinent® metering pumps (recommended) and a stroke volume of approx. 0.03 ... 10 ml. The flow meter normally sits on the discharge side. Clarify with "Technical Support" at head office whether the flow meter can also be installed on the suction side in a special case. All wetted parts are made of PVDF. This ensures that aggressive media can also be measured without problem. The device is installed approximately 30 cm after the pump in the metering line. Interfering influences, such as air bubbles, are identified and an error message concerning them forwarded to the analysis unit. The DulcoFlow can only be used in combination with the delta software if the metering stroke type is set to "fast".

Optionally combined with a delta® series metering pump a DulcoFlow® flow meter can maintain a constant flow.

The DulcoFlow® flow meter can not only be used for recording and measurement of volume flows, but also for monitoring individual metering strokes. In this case the device is calibrated to the stroke volume set at the pump. A lower and upper limit can be entered, which if exceeded or undershot, results in no feedback to the pump. This creates an error message. The connection to the pump takes place via the input for the "Flow Control" dosing monitor

The device is designed for wall mounting.

### 3 Safety chapter



#### Explanation of the safety information

The following signal words are used in these operating instructions to identify different severities of a hazard:

Signal word	Meaning
<b>WARNING</b>	Denotes a possibly hazardous situation. If this is disregarded, you are in a life-threatening situation and this can result in serious injuries.
<b>CAUTION</b>	Denotes a possibly hazardous situation. If this is disregarded, it could result in slight or minor injuries or material damage.

#### Warning signs denoting different types of danger

The following warning signs are used in these operating instructions to denote different types of danger:

Warning signs	Type of danger
	Warning – high-voltage.
	Warning – danger zone.

#### Correct and proper use

- The device may only be used with liquid metering chemicals.
- The device can only be used with pulsing liquid flows with a clear zero flow.

- The device may only be used after it has been correctly installed and commissioned in accordance with the technical data and specifications contained in the operating instructions.
- Observe the general limitations with regard to viscosity limits, chemical resistance and density - see also ProMinent resistance list (In the product equipment catalogue or at [www.prominent.com](http://www.prominent.com))!
- Any other uses or modifications are prohibited.
- The device is not suitable for measuring continuous liquid flows.
- The device may not be used to measure gaseous media or solids.
- The device may not be used with combustible media without appropriate protective measures.
- The device may not be used with explosive media.
- The device may not be used with radioactive media.
- The device is not intended for exterior applications without use of suitable protective equipment.
- The device should only be operated by trained and authorised personnel, see the following "Qualifications" table.
- You are obliged to observe the information contained in the operating instructions at the different phases of the system's service life.



Safety information



**WARNING!**

**Danger of electric shock**

A mains voltage may exist inside the housing.

- If the housing has been damaged, you must disconnect the device from the mains immediately. It may only be returned to service after an authorised repair.



**WARNING!**

**Warning of dangerous or unknown feed chemical**

Should a dangerous or unknown feed chemical be used: It may escape from the hydraulic components during maintenance work.

- Take appropriate protective measures before working on the device (safety glasses, safety gloves, ...). Observe the safety data sheet for the feed chemical.
- Drain and flush the hydraulic parts before working on the device.



**CAUTION!**

**Warning of feed chemical spraying around**

Feed chemical can spray out of the hydraulic components if they are manipulated or opened due to pressure in the hydraulic and adjacent parts of the system.

- Disconnect the pump of the device hydraulic system from the mains power supply and ensure that it cannot be switched on again by unauthorised persons.
- Depressurise the system before commencing any work on hydraulic parts.



**CAUTION!**

**Danger of personnel injury and material damage**

The use of untested third party parts can result in personnel injuries and material damage.

- Only fit parts to the device, which have been tested and recommended by ProMinent.



**NOTICE!**

**Warning of illegal operation**

Observe the regulations that apply where the device is installed.

**Information in the event of an emergency**

In an emergency, disconnect the device from the mains!

If feed chemical escapes, also depressurise the device hydraulic system. Adhere to the safety data sheet for the feed chemical.

### Qualification of personnel

Activity	Qualification level
Storage, transport, unpacking	Instructed personnel
Installation, installation of hydraulic system	Technical personnel
Electrical installation	Electrician
Operation	Instructed personnel
Maintenance	Technical personnel
Repairs	Customer service - authorised by ProMinent
Decommissioning, disposal	Technical personnel
Troubleshooting	Technical personnel, electrician, instructed personnel

### Technical personnel

A qualified employee is deemed to be a person who is able to assess the tasks assigned to him and recognise possible hazards based on his/her technical training, knowledge and experience, as well as knowledge of pertinent regulations.

### Electrician

Electricians are deemed to be people, who are able to complete work on electrical systems and recognize and avoid possible hazards independently based on their technical training and experience, as well as knowledge of pertinent standards and regulations. Electricians should be specifically trained for the working environment in which they are employed and know the relevant standards and regulations. Electricians must comply with the provisions of the applicable statutory directives on accident prevention.

### Instructed personnel

An instructed person is deemed to be a person who has been instructed and, if required, trained in the tasks assigned to him/her and possible dangers that could result from improper behaviour, as well as having been instructed in the required protective equipment and protective measures.

### Customer Service department

Customer Service refers to service technicians, who have received proven training and have been authorised by ProMinent® to work on the system.

## 4 Storage and transport

### Safety information



#### WARNING!

Only return the device for repair in a cleaned state and with flushed hydraulic parts - refer to the chapter "Decommissioning"!

Only send the unit complete with a filled in Decontamination Declaration form. The Decontamination Declaration constitutes an integral part of an inspection / repair order. A unit can only be inspected or repaired when a Decontamination Declaration Form is submitted that has been completed correctly and in full by an authorised and qualified person on behalf of the operator.

The "Decontamination Declaration Form" can be found in the Appendix or under [www.prominent.com](http://www.prominent.com).

#### ! NOTICE!

#### Danger of material damage

The device can be damaged by incorrect or improper storage or transportation!

- The device should only be stored or transported in a well packaged state - preferably in its original packaging.
- The packaged unit should also only be stored or transported in accordance with the stipulated storage conditions.
- The packaged unit should be protected from moisture and the ingress of chemicals.

### Ambient conditions

Data	Value	Unit
Minimum storage and transport temperature	-10	°C
Maximum storage and transport temperature	+50	°C
Air humidity	< 95	% rel. humidity*

\* non-condensing

## 5 Overview of equipment

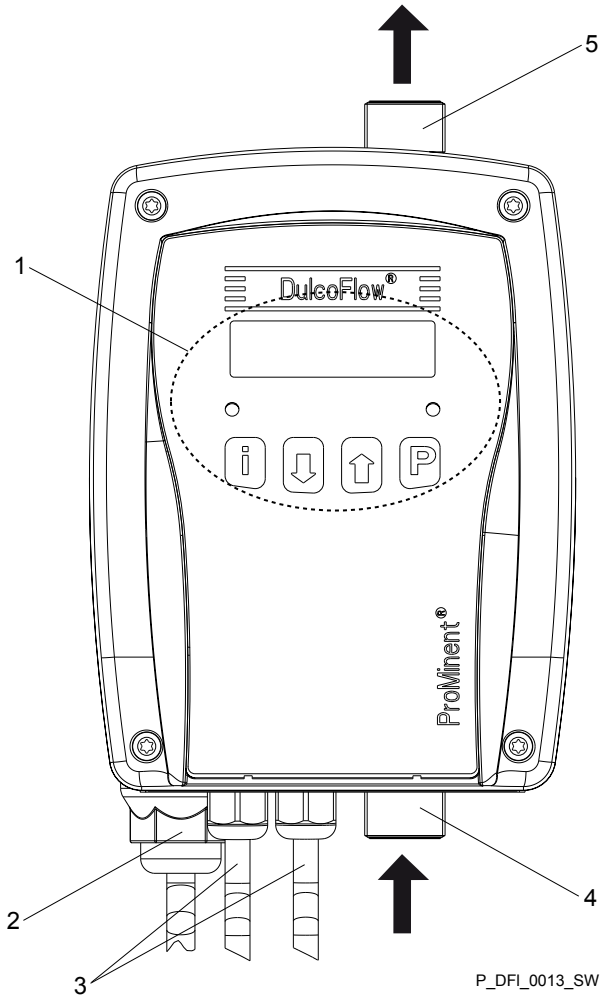

Fig. 2: Overview of equipment DulcoFlow® with arrows showing flow

- |   |  |   |                         |
|---|--|---|-------------------------|
| 1 | Control elements - see chapter "Settings" - "Operating unit" | 3 | Signal outputs (option) |
| 2 | Mains connection   | 4 | Feed chemical inlet     |
|   |  | 5 | Feed chemical outlet    |

## **6 Functional description**

The DulcoFlow® flow meter measures the volume flow of pulsing flows. The ultrasonic, time of flight measurement method is used. For the time of flight measurement, a sound signal is alternately transmitted in and against the direction of flow. The time difference is then a measure of the mean flow velocity. Use of the ultrasound measurement method automatically compensates any temperature induced changes in the medium. Operation without moving parts guarantees a long service life and wear-free operation.

The DulcoFlow® calculates the mass flow from the volume flow and the density of the feed chemical.

Additionally the DulcoFlow® can measure the metering strokes of the metering pump and hence replace a dosing monitor such as the Flow Control. A metering pump, such as the gamma or delta®, can use these signals as acknowledgement pulses for its individual strokes. If the acknowledge pulses are missing or if the capacity exceeds the specified limit values, the metering pump stops after an adjustable number of missing pulses and goes into fault mode - see metering pump operating instructions.

The DulcoFlow® gives the flow reading, stroke feedback, or error messages via the various output types. It is also possible to regulate the flow using a delta® with a control module.

# 7 Assembly and Installation

## Safety Information



### WARNING!

Assemble the device prior to undertaking the electrical installation.



### WARNING!

Observe the information in the "Technical data" chapter.



### WARNING!

#### Danger of electric shock

If the device is used outdoors without a cover or weatherproof roof, water may be able to collect on the seals and penetrate the housing or direct sunlight may cause the housing to be corroded.

- Always use a cover or weatherproof roof when using the unit outdoors.



### CAUTION!

#### Warning against illegal operation

Observe the regulations that apply where the device is installed.



*The device is resistant to normal atmospheres in plant rooms.*

## 7.1 Assembly



*Install the device so that the hose between it and the pump is approximately 20 ... 30 cm long.*

*This ensures it measures accurately.*



*Mount the device vertically and upright.*

*This ensures it measures accurately.*



*For **suction-side** assembly (minimum requirements):*

*Route the suction line so that it has a constant upwards slope and use a foot valve (prevents air bubbles and vibrations).*



Mount the device vertically and upright on the wall using the two eyes on the housing.



*Do not forget the washers.*

## 7.2 Installation, hydraulic

### CAUTION!

#### Warning of escaping feed chemical

Feed chemical can escape in the event that the hose lines are incorrectly installed.

- Only use original hoses with the specified hose dimensions.
- Avoid reducing the hose sizes.



#### Flow direction

The flow direction through the device goes from the bottom to the top.



#### Hydraulic dampers

Install hydraulic dampers, such as accumulators, inline dampers or bladder accumulators / diaphragm accumulators downstream of the DFMs.

A zero flow must be available.

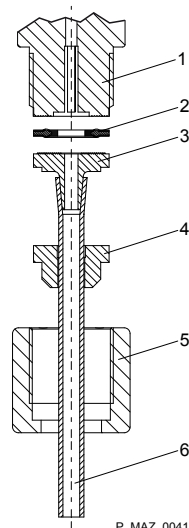





P\_MAZ\_0041\_SW

Fig. 3: Installing the hose line

- 1 Connector
- 2 Seal
- 3 Nozzle
- 4 Clamp ring
- 5 Union nut
- 6 Hose

#### Installing the hosing:

1.  Cut off the ends of the hoses (6) so that they are straight.
2.  Unscrew the union nut (5) and push over the hose together with the clamp ring (4).
3.  Push the hose end (6) up to the stop over the nozzle (3).
4.  Tighten the union nut (5).
5.  Pull on the hose (6) and tighten up the union nut (5).

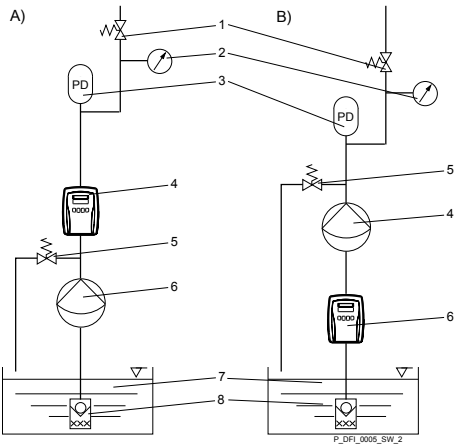

Fig. 4: Hydraulic system of the DulcoFlow®. A) discharge-side, B) suction-side

- 1 Back pressure valve
- 2 Manometer (recommended)
- 3 Hydraulic Damper (optional)
- 4 DulcoFlow®
- 5 Overflow device (optional)
- 6 Metering pump
- 7 Storage tank
- 8 Foot valve

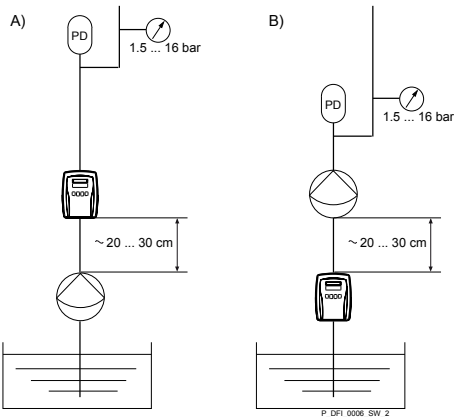

Fig. 5: Hydraulic installation parameters. A) discharge-side, B) suction-side



Clarify with "Technical Support" at head office whether the flow meter can also be installed on the **suction side** in a special case.

## 7.3 Installation, electrical



### WARNING!

#### Danger of electric shock

The use of a residual current circuit breaker drastically increases survival chances should persons come into contact with the mains voltage due to an electrical accident.

- Always fit a residual current circuit breaker on-site.

A metering pump, monitor, PLC or other devices can be connected to the flow meter.

The following alternative electrical outputs are available via cable:

- Current output (identity code characteristic "signal output" "1");
- Counter output (identity code characteristic "signal output" "2");
- Current output and counter output (identity code characteristic "signal output" "3");
- Controlled pump output (identity code characteristic "signal output" "4");



### 7.3.1 Current output

#### Current output

The following can be signalled via the current output (standard signal output (mA)):

- Instantaneous flow
- Fault

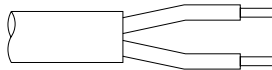

P\_DFI\_0011\_SW

Fig. 6

Lead	Function
brown	+
white	-

Technical data:

Data	Value	Unit
Current*	0/4 .. 20	mA
Maximum load	400	Ω

\* zero volt connection

Max. cable length	30 m
-------------------	------

### 7.3.2 Counter output

#### 7.3.2.1 Counter output as stroke feedback output

##### Counter output as stroke feedback output

The counter output as stroke feedback output can be used to signal stroke feedback, provided it is set accordingly - see chapter "Settings".

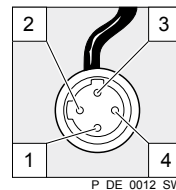

P\_DE\_0012\_SW

Fig. 7

# Assembly and Installation

1. ➔ To report stroke feedback on the metering pumps – such as gamma and delta®, plug the cable from the flow meter on the pump into the "dosing monitor" terminal.
  - ⇒ The identifier for the dosing monitor must appear on the LCD screen of the pump.
2. ➔ If it does not appear, make the necessary settings at the metering pump.

## 7.3.2.2 Counter output as frequency output

### Counter output as frequency output

The counter output as frequency output can be used to signal flow or an error, provided it is set accordingly - see chapter "Settings".

1. ➔ Remove the connected socket.
2. ➔ Remove the insulation of the leads to match the terminals of your monitor.
3. ➔ Crimp on a suitable cable end sleeve.
4. ➔ Connect the cable to the monitor in accordance with the following connection information and the operating instructions supplied with the monitor:

### NPN connection information

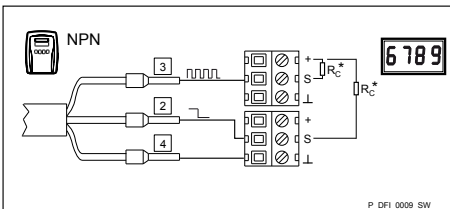

Fig. 8: Wiring diagram NPN-outputs to indicating instrument or PLC

Rc\* Collector resistance or pull-up resistance. For more information - see the next page

### Pin assignment

Pin	Lead	Function	Value range	Unit
-	-	Supply voltage (monitor)	5 ... 30	VAR-IOUS SET-TINGS
2	white ***	Error signal	high = yes low = no	-
3	blue ***	Frequency signal**	0 ... 10000	Hz
4	black ***	GND	0	VAR-IOUS SET-TINGS

\*\* Open collector. \*\* Rectangular pulses; pulse: Pause = 1 : 1.

At frequencies below 10 Hz: The pulse length is fixed at 20 ms and the pulse interval varies with the signal to be emitted.

\*\*\* zero volt connection

### PNP connection information

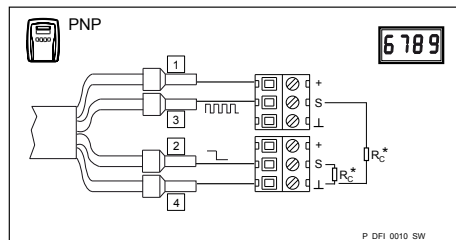

Fig. 9: Wiring diagram PNP-outputs to indicating instrument or PLC

Rc\* Collector resistance or pull-up resistance. For more information, see below.

## Pin assignment

Pin	Lead	Function	Value range	Unit
1	brown	Supply voltage (monitor)	5 ... 30	VARIOUS SETTINGS
2	white ***	Error signal	low = yes high = no	-
3	blue ***	Frequency signal**	0 ... 10000	Hz
4	black ***	GND	0	VARIOUS SETTINGS

\*\* Open collector. \*\* Rectangular pulses; pulse: Pause = 1 : 1.

At frequencies below 10 Hz: The pulse length is fixed at 20 ms and the pulse interval varies with the signal to be emitted.

\*\*\* zero volt connection

## Collector resistance $R_C$ , minimum level



### CAUTION!

The current  $I$  through the signal leads must be limited by means of a suitably scaled collector resistor  $R_C$ , as otherwise the output transistors may be damaged.



*The lower the value of collector resistor  $R_C$ , the further the frequency signal can be transported without distortion - see  $\psi$  'Collector resistance  $R_C$  for frequency signal lead' on page 20.*

*The lower the value of collector resistor  $R_C$ , the higher the frequencies which can be transported without distortion - see  $\psi$  'Collector resistance  $R_C$ , minimum level' on page 19.*

The following applies to collector resistor  $R_C$  on an external device:

- It may already be integrated in the device
- It may already be integrated in a low-pass filter in the device
- It may be possible to connect it on the device
- It may be missing entirely and must then be screwed to the terminals.

Refer to the operating instructions for the external device.

Search terms:

- Collector resistor
- Pull-up resistance
- Open-collector input or O.C.

## Minimum value for $R_C$ dependent on supply voltage $U$

Supply voltage $U$	$R_{C \min}$
5 V	100 $\Omega$
9 V	180 $\Omega$
12 V	240 $\Omega$
24 V	480 $\Omega$
30 V	680 $\Omega$

$$R_{C \min} = U / 0.050 \text{ A}$$

### Collector resistance $R_C$ for frequency signal lead



The collector resistance  $R_C$  (or pull-up resistance) and the cable capacity  $C_K$  form an RC member which smooths the edges of the rectangular pulse. The collector resistor  $R_C$  for the frequency signal lead should be selected to be as low as possible above  $R_C$  - dependent on the maximum frequency and the requirements on the slope rate for the monitor being used.

### Maximum cable lengths for various $R_C$ and $f_{\max}$

$R_C^*$	$f_{\max}$		
$\Omega$	0.5 kHz	1 kHz	10 kHz
100 000	2.5 m	0.7 m	-
10 000	30 m	17	0.7 m
1 000	30 m	30 m	17 m
680	30 m	30 m	25.5 m
480	30 m	30 m	30 m
240	30 m	30 m	30 m
180	30 m	30 m	30 m
100	30 m	30 m	30 m

\* Minimum value depending on the supply voltage supplied by your monitor - refer to its operating instructions and table [↗ 'Collector resistance  \$R\_C\$ , minimum level'](#) on page 19.

The table applies to cable with a specific capacity of 100 pF/m and in any case unshielded cable such as type LiYY control cabling supplied by e.g. Lapp.

### Selection of collector resistor $R_C$

- Supply voltage of monitor = 30 V
- Rating for maximum frequency  $f_{\max} = 10$  kHz

1. ➔ Use table [↗ 'Collector resistance  \$R\_C\$ , minimum level'](#) on page 19 to look up the value for  $R_C$  corresponding to 30 V.

⇒ This is 680  $\Omega$ .

2. ➔ Refer to table [↗ 'NPN connection information'](#) on page 18 with the row for 680  $\Omega$  and search for the length value from the column for  $f_{\max} = 10$  kHz.

⇒ This amounts to 25.5 m.

### 7.3.3 Current output and counter output

#### Current output

The device has both a current output (standard signal output (mA)) and also a counter output. For a description of these outputs - see [↗ Chapter 7.3.1 'Current output'](#) on page 17 and [↗ Chapter 7.3.2 'Counter output'](#) on page 17.

### 7.3.4 Output for controlled pump

#### Current output

The device has an output for a controlled pump. I.e., in conjunction with a delta® series metering pump a DulcoFlow® flow meter can maintain a constant flow. To do this plug the cable plug into control module socket. For more information - see the "Supplementary operating instructions for the delta® solenoid metering pump - control module delta®".

## 8 Set up

### 8.1 Operating unit

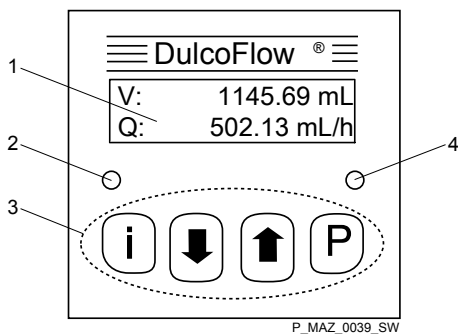

Fig. 10: Operating unit DulcoFlow®

- 1 LCD screen
- 2 Status LED
- 3 Control keys
- 4 Stroke feedback LED

#### 8.1.1 LCD screen

The LCD screen comprises a two-line display.

#### 8.1.2 LEDs

The status LEDs (left) shows the following information:

LED	Information
green	Status OK
orange	Warning
red	Fault

The stroke feedback LED (right) shows the following information:



LED	Information
off	No pressure surge identified
green, illuminated	Pressure surge detected - within tolerance
red, illuminated	Pressure surge detected - outside tolerance

#### 8.1.3 Control keys

The control keys are designated as follows:

Key	Description
	[i]
	[DOWN]
	[UP]
	[P]

# Set up

  = set-up option

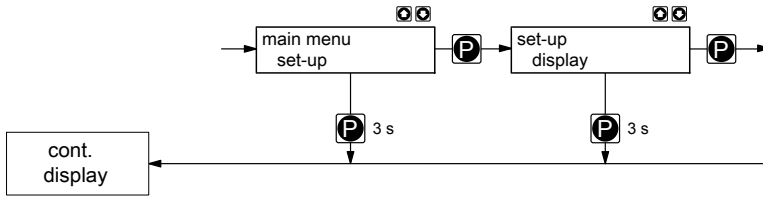









Fig. 11: Navigation within the operating menu



The control keys have different functions in the continuous display, in the operating menu and in the menu branches.

## In the continuous display





Key	Functions
	Changes to continuous display
	Changes into the operating menu (press for 2s)
 +	Reset the total quantity and the strokes, which are displayed in the continuous display, to "zero".
	
 +	Reset to factory settings (press for 10 s)
	

Key	Functions
	Open menu branch (switch to the first item of the selected menu branch).

## In the operating menu

Key	Functions
	Change to the previous menu branch
	Change to the next menu branch

## In a menu item of a menu branch

Key	Functions
	Switches between the continuous changing of a number and digit by digit changing
	Increase/change the set value
	Reduce/change the set value
	Accept the configured value and change to the next menu item of the menu branch.  In digit by digit changing: Within a number change to the next figure.

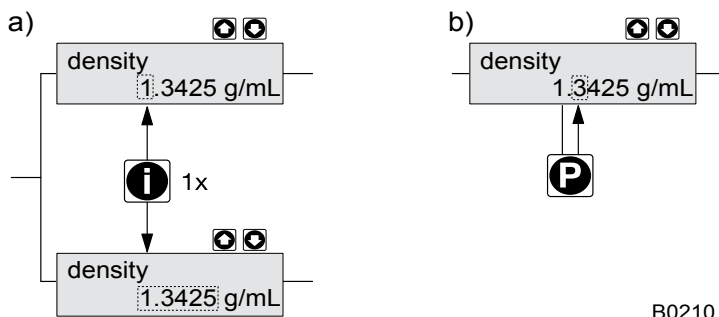

B0210

Fig. 12: a) Change between continuous changing of a number and digit by digit changing; b) Changes the position within the number

## Key [P] - additional generally-applicable functions:

Press duration	Function
approx. 2 s	Open the operating menu
approx. 3 s	Quit the operating menu without saving the configured values and return to the continuous display



A modified set value is only adopted, if it has previously been confirmed by briefly pressing [P].

## 8.2 Check display variables

Before you adjust the flow meter, you can check the current display variables on the continuous display:

## Set up

Press  $[i]$  ("i" for "Information"), if the LCD screen is displaying a continuous display - i.e. no display of the operating menu.

⇒ Each press of the  $[i]$  key toggles the continuous display output to the screen to another continuous display.

The appearance of the continuous displays depend on the selected measured variables (volumes or mass) - see below.



Press  $[i]$  to switch from continuous display to continuous display.

### Continuous display for the "Volume" measured variable

Continuous display	Description	
m: Q:	243,32 mL 171,05 mL/h	Total quantity* V and instantaneous volume flow Q
V: N:	243,32 mL 637	Total quantity* V and number of strokes* N
V/H: %SH:	0,382 mL 102,3 %	Volume per stroke V/H and deviation from the setpoint of the stroke volume %SH

\* since the last reset

### Continuous displays for the "Mass" measured variable

(If 'mass' was set under 'Operation' → 'Measured variable'.)

Continuous display	Description	
m: Q:	326,05 g 229,21 g/h	Total quantity* m and instantaneous mass flow Q
m: N:	326,05 g 527	Total quantity* m and number of strokes* N
m/H: %SH:	0,619 g 97,8 %	Mass per stroke m/H and deviation from the setpoint of the stroke mass %SH

\* since the last reset



#### Reset values

- Press the two [arrow keys] to set the total quantity and strokes to zero.
- In the main menu "Zero set", the total quantity and the strokes can be set to "zero" independently of each other.



### 8.3 Operating menu overview

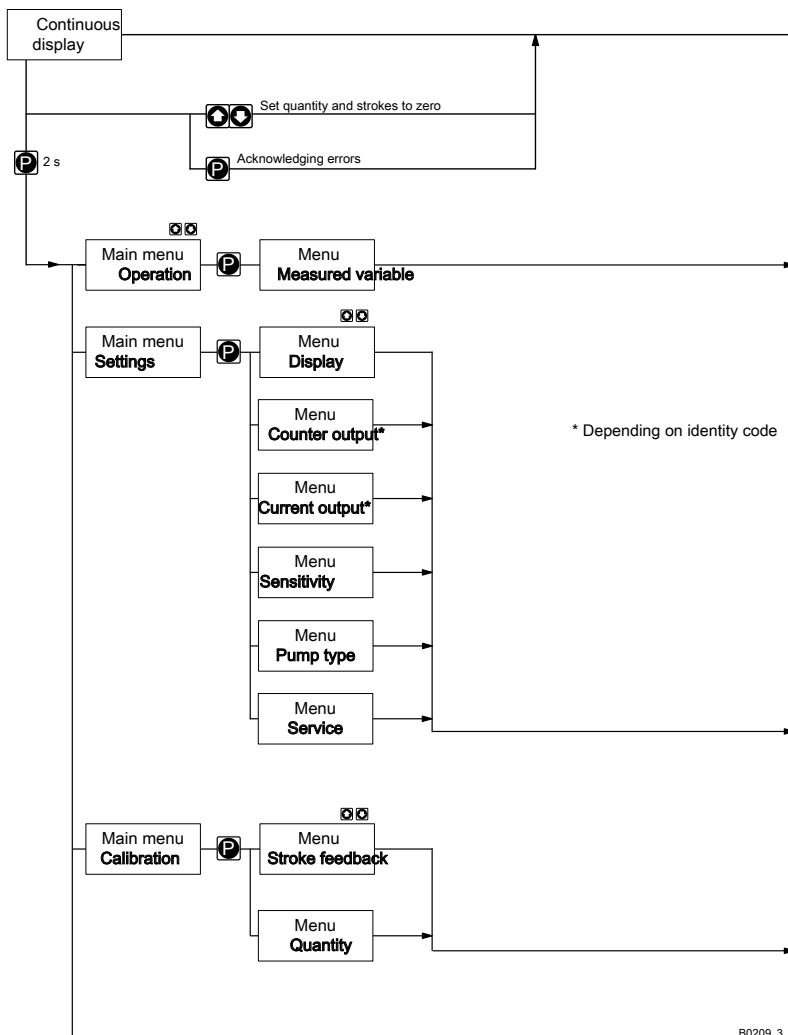

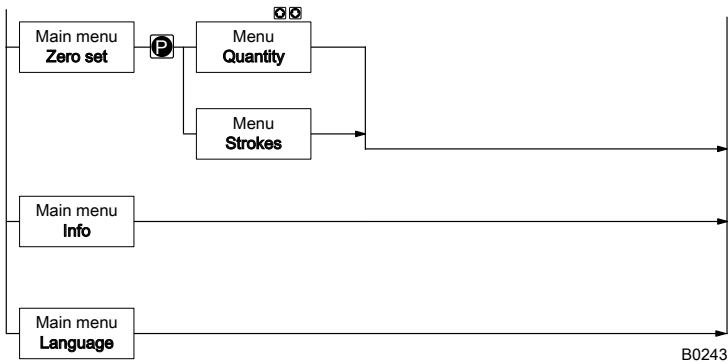

## 8.4 Changing to adjustment mode

If *[P]* is pressed for 2 seconds in a continuous display, the device changes to adjustment mode.

The following main menus can be selected in adjustment mode:

- 1 - Operation
- 2 - Settings
- 3 - Calibration
- 4 - Zero set
- 5 - Info
- 6 - Language

### 8.4.1 "Operation" main menu

main menu  
mode

The measured variables can be selected from the "Operation" main menu:

- 'Volume' (-flow)
- 'Mass' (-flow)
- 'Quantity' (-flow)

The appearance of a few menus is dependent on this.

If 'Mass' is selected, then the mass density of the medium must be additionally entered.

### 8.4.2 "Set-up" main menu

main menu  
set-up

The following menus can be selected from the "set-up" main menu:

- 1 - 'Display'
- 3 - 'Current output' (identity code characteristic "signal output" "1")
- 2 - 'Counter output' (identity code characteristic "signal output" "2")
- 4 - 'Service' (for customer service only)

### 8.4.2.1 "Display" menu

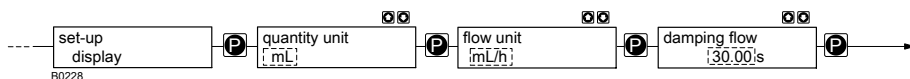

In the '*display*' menu, the units can be selected for the quantities and flow.

Moreover, the damping of the displayed flow values can be changed (not for quantities), if they change too quickly / slowly in the display.

The greater the set integration constant in the menu item '*damping flow*', the greater the damping of the displayed flow values.

#### Non-metric units and their conversion

Unit	Meaning	Conversion
1 gal	1 US liquid gallon	= 3.785421 L
1 lb(s)	1 Pound	= 453.59237 g

### 8.4.2.2 "Counter output" menu

(for identity code characteristic "signal output" "2" and "3")

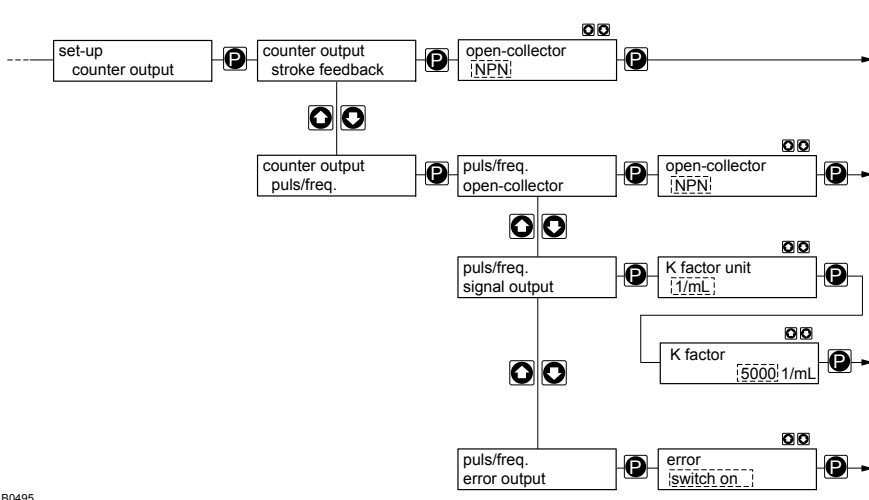

B0495

In the '*counter output*' menu the counter output can be set either as a pulse/frequency output to output the instantaneous flow, as an error signal or as a feedback message.

### **pulse/frequency (frequency output)**

Firstly the type of the output ( '*Open-Collector*' ) can be selected so that it is suitable for the connected device (NPN / PNP).

The K factor can be set via the '*signal output*' menu. This is then used by the DulcoFlow® to convert the current Q flow via the counter output to an external device as frequency f.

$f = K * Q$  with

Frequency f in Hz

K factor K in 1/mL or pulse/mL

Flow Q in mL/s

The DulcoFlow® gives an error message in the event that these pre-specified limit values are exceeded and the status LED (left) lights up in orange.

In the '*error output*' menu a setting can be made to determine whether the DulcoFlow® outputs an error signal via the counter output to an external device. It works like a relay in status NO.

### **Stroke feedback**

For stroke feedback, e.g. to a Prominent metering pump, as with a Flow Control® dosing monitor, the cable must be fed from the counter output to the "dosing monitor" terminal of the metering pump.

Then the '*stroke feedback*' must be calibrated under '*calibration*', see chapter "Calibration".

### 8.4.2.3 "Current output" menu

(for identity code characteristic "signal output" "1", "3" and "4")

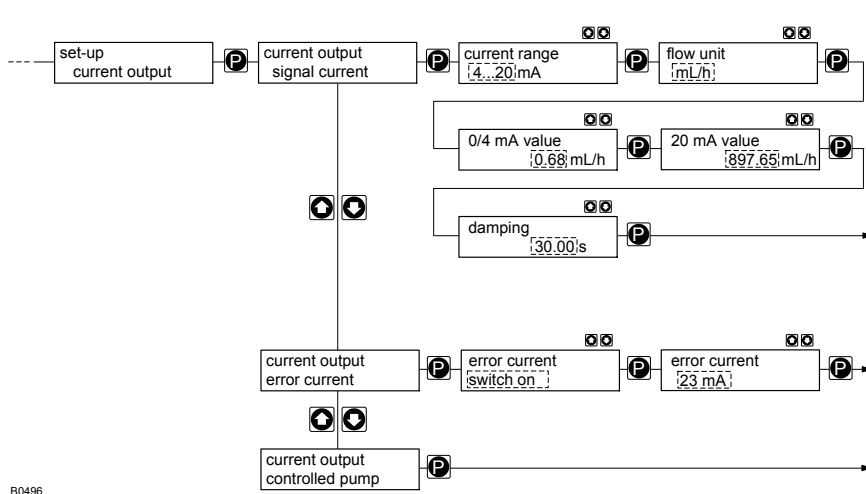

B0496

In the *'current output'* menu the standard signal output (mA) can be set either to output the instantaneous flow, an error signal or to interact with the control module of a metering pump delta®.

In the *'signal current'* menu a setting can be made to determine how the DulcoFlow® outputs the instantaneous flow via the current output to an external device.

You can enter any behaviour for the current signal proportional to the flow. In order to do so, it is possible e.g. to enter any two points P1 (4 mA, Q1) and P2 (20 mA, Q2) (Q1 is the flow at which the DulcoFlow® outputs 4 mA.); this means that one line is specified and the behaviour:

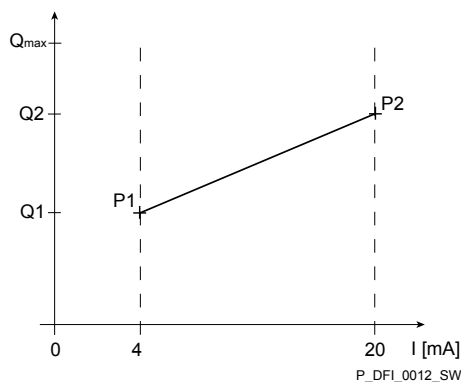

Fig. 13: Diagram for flow Q as current signal (here: 4 ... 20 mA)

---

## Set up

---



*Plot a diagram as shown above - with values for (4 mA, Q1) and P2 (20 mA, Q2) or (0 mA, Q1) and P2 (20 mA, Q2) - in order to be able to output flow Q of the DulcoFlow® as desired as a current signal.*

The DulcoFlow® gives an error message in the event that these pre-specified limit values are exceeded and the status LED (left) lights up in orange.

Moreover, the damping of the displayed flow values can be changed (not for quantities), if they change too quickly / slowly in the display.

The greater the set integration constant in the menu item '*damping*', the greater the damping of the displayed flow values.

In the '*error output*' menu a setting can be made to determine whether the DulcoFlow® outputs an error signal via the current output to an external device (23 / 3.6 mA).

If the '*controlled pump*' menu is selected, the DulcoFlow® with the control module of a metering pump delta® can control the flow - see the "Supplementary operating instructions for the metering pump delta® - control module delta®".

### 8.4.2.4 "Sensitivity" menu

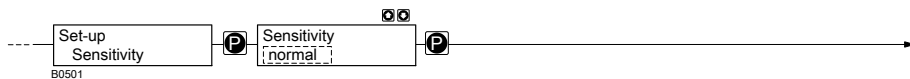

The sensitivity of the device to disturbances, like air bubbles, can be reduced in the "Sensitivity" menu.

At the same time, this also reduces measuring sensitivity.

Sensitivity setting	Sensitivity to air bubbles	Measuring accuracy
Normal	high	high
...	...	...
Step 4	low	low

### 8.4.2.5 "Pump type" menu

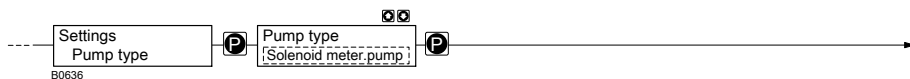

The pump type has to be set in the "Pump type" menu.

### 8.4.2.6 "Service" menu

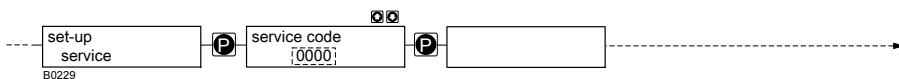

The "service" menu is password protected and only for customer service.

### 8.4.3 "Calibration" main menu

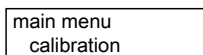

From the "calibration" menu either the flow measurement can be calibrated or the stroke feedback set up.

### 8.4.3.1 Calibrate "stroke feedback"

#### 8.4.3.1.1 For "volume"

The permitted range for the stroke volume V/H can be specified in this menu. If the stroke volume moves outside of this range, e.g. due to a changed back pressure, the DulcoFlow® no longer gives any stroke feedback to the

---

## Set up

---

metering pump and the right LED now illuminates as a steady red instead of green. ProMinent metering pumps, such as the gamma or delta<sup>®</sup> go into fault mode after a series of defective strokes (pump set up).



## About setpoint and tolerances

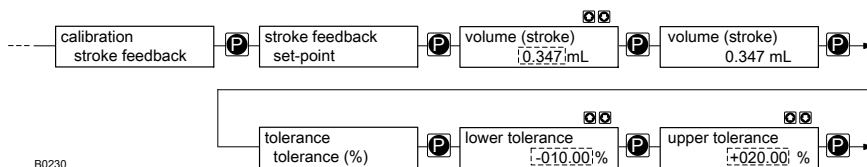

Specify the allowed range for the stroke volume V/H via the setpoint of the stroke volume V/H and tolerances in %:

1. Follow the menu path *'Calibration → Stroke feedback → Set-point'* and press *[P]*.
  - ⇒ The menu item *'volume (stroke)'* displays the currently stored setpoint.
2. Start the metering pump.
  - ⇒ The actual measured value is displayed.
3. Turn the stroke length adjustment knob until the desired setpoint is displayed.
4. Press the *[P]* key.
  - ⇒ The displayed measured value is saved as a setpoint and the menu item *'tolerance tolerances'* appears.



*The setpoint is valid as 100%.*

5. Stop the metering pump.
6. Press the *[P]* key.
7. Enter the *'lower tolerance'* using the *[arrow keys]* and press *[P]*.
8. Enter the *'upper tolerance'* using the *[arrow keys]* and press *[P]*.
  - ⇒ The continuous display appears again.



*The desired setpoint can also be entered, without having to use the stroke adjustment dial or the pump having to be running, directly under 'volume (stroke)' using the [arrow keys].*

### Upper limit values

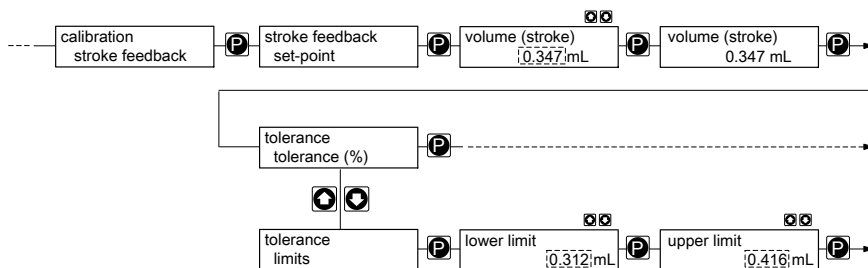

B0231

Alternatively, the desired limits for the allowed range of the stroke volume can be entered under 'lower limit' and 'upper limit':

1. Follow the menu path 'Calibration → Stroke feedback → Set-point' and press [P].  
⇒ The menu item 'volume (stroke)' displays the currently stored setpoint.
  2. Start the metering pump.  
⇒ The actual measured value is displayed.
  3. Turn the stroke length adjustment knob until the desired setpoint is displayed.
  4. Press the [P] key.  
⇒ The displayed measured value is saved as a setpoint and the menu item 'tolerance tolerances' appears.
-  The setpoint is valid as 100%.
5. Use the [arrow keys] to toggle to the 'Tolerance limit values (abs)' menu item and press [P].
  6. Turn the stroke length adjustment dial down until the desired lower limit is reached and press [P].
  7. Proceed in the same way for the upper limit.  
⇒ The continuous display appears again.
  8. Stop the metering pump.



*The desired setpoint can also be entered, without having to use the stroke adjustment dial or the pump having to be running, directly under 'volume (stroke)' using the [arrow keys].*

#### 8.4.3.1.2 For "Mass"

The permitted range for the mass per stroke m/H can be specified in this menu. If the mass per stroke moves outside of this range, e.g. due to a changed back pressure, the DulcoFlow® no longer gives any stroke feedback to the metering pump and the right LED now illuminates as a steady red instead of green. ProMinent metering pumps, such as the gamma or delta® go into fault mode after a series of defective strokes (pump set up).

### About setpoint and tolerances

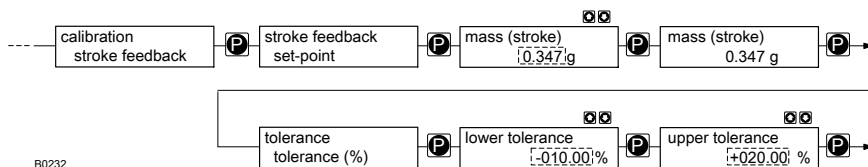

Specify the allowed range for the mass per stroke m/H via the setpoint of the stroke volume m/H and tolerances in %:

1. Follow the menu path *'Calibration → Stroke feedback → Set-point'* and press [P].
  - ⇒ The menu item *'mass (stroke)'* displays the currently stored setpoint.
2. Start the metering pump.
  - ⇒ The actual measured value is displayed.
3. Turn the stroke length adjustment knob until the desired setpoint is displayed.
4. Press the [P] key.
  - ⇒ The displayed measured value is saved as a setpoint and the menu item *'tolerance tolerances'* appears.



*The setpoint is valid as 100%.*

5. Press the [P] key.
6. Enter the *'lower tolerance'* using the [arrow keys] and press [P].
7. Enter the *'upper tolerance'* using the [arrow keys] and press [P].
  - ⇒ The continuous display appears again.
8. Stop the metering pump.



*The desired setpoint can also be entered, without having to use the stroke adjustment dial or the pump having to be running, directly under 'Mass (stroke)' using the [arrow keys].*

## Upper limit values

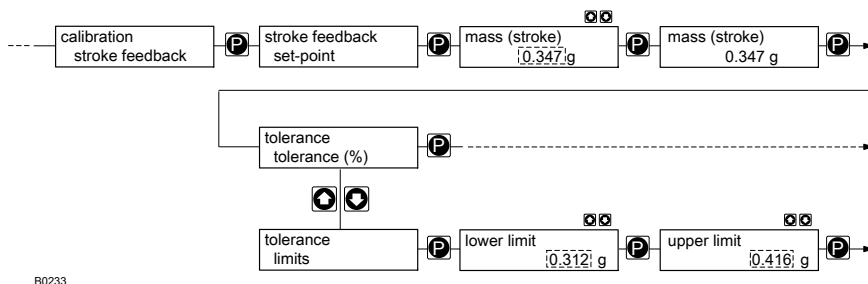

Alternatively, the desired limits for the allowed range of the stroke mass can be entered under *'lower limit'* and *'upper limit'*:

1. Follow the menu path *'Calibration → Stroke feedback → Set-point'* and press *[P]*.
  - ⇒ The menu item *'mass (stroke)'* displays the currently stored setpoint.
2. Start the metering pump.
  - ⇒ The actual measured value is displayed.
3. Turn the stroke length adjustment knob until the desired setpoint is displayed.
4. Press the *[P]* key.
  - ⇒ The displayed measured value is saved as a setpoint and the menu item *'tolerance tolerances'* appears.



*The setpoint is valid as 100%.*

5. Use the *[arrow keys]* to toggle to the *'Tolerance limit values (abs)'* menu item and press *[P]*.
6. Turn the stroke length adjustment dial down until the desired lower limit is reached and press *[P]*.
7. Proceed in the same way for the upper limit.
  - ⇒ The continuous display appears again.
8. Stop the metering pump.



*The desired setpoint can also be entered, without having to use the stroke adjustment dial or the pump having to be running, directly under 'Mass (stroke)' using the [arrow keys].*

### 8.4.3.2 Calibrate "quantity"



*Only calibrate the quantity flow if the displayed values do not attain the expected accuracy.*



*Under the option "Output for controlled pump", deactivate the control.*

### 8.4.3.2.1 By input

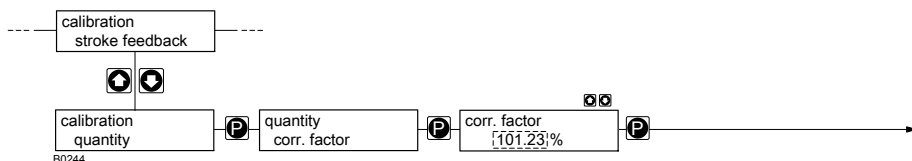

If the new correction factor is known in %, it can be entered directly here.

It is obtained by dividing a value you have measured yourself by the displayed value and multiplying the result by 100.

1. ➤ Follow the menu path '*calibration* → *stroke feedback*'.
2. ➤ Use the [arrow keys] to toggle to the '*Calibration quantity*' menu item and press [P] twice.
3. ➤ Use the [arrow keys] to enter the '*Corr. factor*' and press [P].
  - ⇒ The continuous display appears again.

### 8.4.3.2.2 By measured values



#### CAUTION!

#### Danger with dangerous feed chemicals

Provided the following handling instructions are followed, contact with the feed chemical is possible.

- If the feed chemical is dangerous, take appropriate safety precautions when carrying out the following handling instructions.
- Observe the feed chemical safety data sheet.

Depending on the set measured variable, a calibration menu appears for:

- Volume
- Mass

# Set up



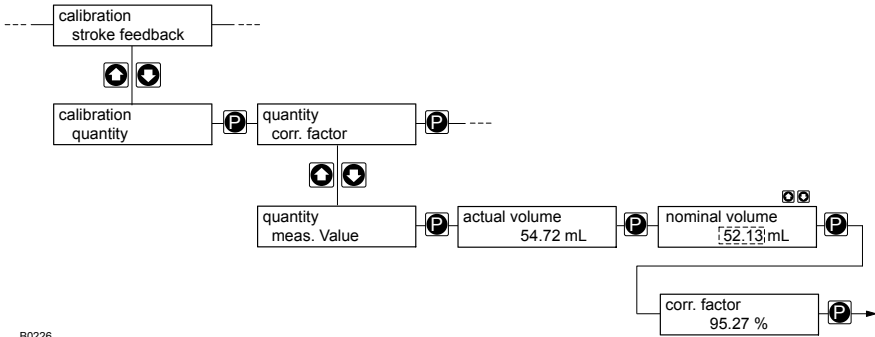

## Volume



B0226







## Requirements:

- 1 measuring cylinder which can be read sufficiently accurately
  - The metering pump suction line is fed, bubble-free into the measuring cylinder.
1.  Record the fluid level in the measuring cylinder.
  2.  Switch from the 'Calibration stroke feedback' menu item using the [arrow keys] to the 'Calibration quantity' menu item and press [P].
    - ⇒ The menu item 'Quantity corr. factor' appears.
  3.  Switch from the 'Quantity input' menu item using the [arrow keys] to the 'Measured value quantity' menu item and press [P].
    - ⇒ The menu item 'Actual volume' appears.
  4.  Start the metering pump.



Select the number of strokes so that the reading error at the measuring cylinder (half of the smallest readable volume graduation divided by the metered total volume) is smaller than the Dulcoflow<sup>®</sup> measurement error.

5.  Stop the metering pump.
6.  Record the fluid level in the measuring cylinder and calculate the difference.
7.  Press the [P] key.
  - ⇒ The menu item 'nominal volume' appears.
8.  Adjust the value in the 'Actual volume' menu item to this differential value using the [arrow keys] and press [P].
  - ⇒ The menu item 'Corr. factor' appears. It shows the calculated correction factor.
9.  Press [P] to return to the continuous display.

It is also possible to manually calculate the correction factor and enter it directly under 'entry' - 'corr. factor'.

# Set up



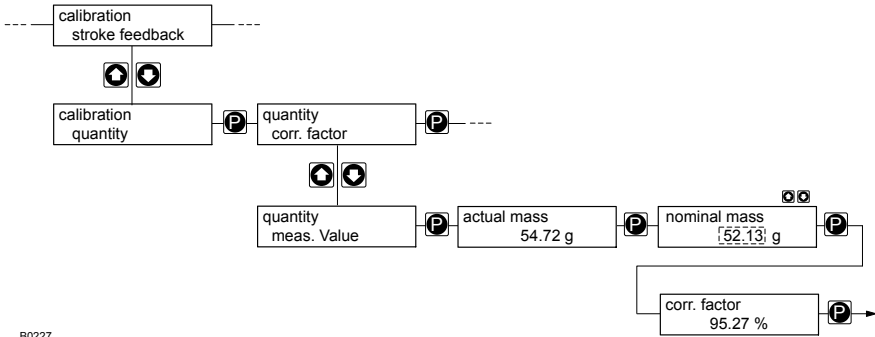

## Earth



B0227





## Requirements:

- 1 weighing instrument which can be read sufficiently accurately
- 1 vessel with feed chemical
- the metering pump's suction line is fed, bubble-free into the measuring vessel.

1.  Zero the weighing instrument.
2.  Switch from the 'Calibration stroke feedback' menu item using the [arrow keys] to the 'Calibration quantity' menu item and press [P].
  - ⇨ The menu item 'Quantity corr. factor' appears.
3.  Switch from the 'Quantity input' menu item using the [arrow keys] to the 'Measured value quantity' menu item and press [P].
  - ⇨ The menu item 'actual mass' appears.
4.  Start the metering pump.



Select the number of strokes so that the reading error at the weighing instrument (half of the smallest readable mass graduation divided by the metered total mass) is smaller than the Dulcoflow measurement error.

5.  Stop the metering pump.
6.  Read off the weight from the weighing instrument.
7.  Press the [P] key.
  - ⇨ The menu item 'nominal mass' appears.
8.  Adjust the value in the 'Nominal volume' menu item to the weight read off using the [arrow keys] and press [P].
  - ⇨ The menu item 'Corr. factor' appears. It shows the calculated correction factor.
9.  Press [P] to return to the continuous display.

It is also possible to manually calculate the correction factor and enter it directly under 'entry' - 'correction factor'.

#### 8.4.4 "Zero set" main menu

main menu zero set
-----------------------

In the main menu "Zero set", the total quantity and the strokes, which are displayed in the continuous display, can be set to "zero" independently of each other.



*If the arrow keys are simultaneously pressed, the total quantity and the strokes are simultaneously set to "Zero".*

*Holding down [ i ] and [P] simultaneously for 10 s, resets the device to its factory settings - see "Factory settings" at the end of the operating instructions.*

### 8.4.5 "Info" main menu

main menu
info

This information can be read-off in the "Info" main menu:









Code	Meaning
ID	Identity code
SN	Serial number
HW	Hardware version
SW	Firmware version
BL	Bootloader version

### 8.4.6 "Language" main menu

main menu
language

The operating language can be selected from the "language" main menu.

## 9 Start up

1.  Connect the device hydraulically with the overall installation.
2.  Connect the signal cables for the device.
3.  Connect the device to the supply voltage.
4.  If necessary set:
  - the 'language' - see *Chapter 8.4.6 "Language" main menu' on page 44*
  - the 'pump type' - see *Chapter 8.4.2.5 "Pump type" menu' on page 31*
  - the measured variable to "mass" and density of the feed chemical - see *Chapter 8.4 "Changing to adjustment mode' on page 26*
  - the units - see *Chapter 8.4.2.1 "Display" menu' on page 27*
  - the current output - see *Chapter 8.4.2.3 "Current output" menu' on page 29*
  - the counter output - see *Chapter 8.4.2.2 "Counter output" menu' on page 27*
5.  Allow the metering pump to prime and bleed the installation - simultaneously press both *[arrow keys]* on the pump's control unit.
6.  On the unit, press *[P]* to acknowledge the 'gas bubbles' fault.
7.  Allow the metering pump to run.
8.  If used as a dosing monitor: Check whether the stroke feedback to the metering pump is plausible.
 

If this is not the case, proceed in accordance with the handling instructions, which can be found after the tips.
9.  Check whether the displayed values are plausible.

If this is not the case, proceed in accordance with the handling instructions, which can be found after the tips.

10.  Check whether the frequency signals and the mA signals of the device have the expected effect if these signals are being used.

If this is not the case, proceed in accordance with the handling instructions, which can be found after the tips.





Press *[P]* to acknowledge if the metering pump goes into fault mode during start up.





For use with the metering pump delta<sup>®</sup> set to "dosing" - "set-up" (discharge stroke)" - "fast".

### Operation as a dosing monitor

1.  Under 'set-up → set counter output' to 'stroke feedback'.
2.  In the menu 'calibration' set the 'stroke feedback' - see *Chapter 8.4.3.1 Calibrate "stroke feedback" on page 31*

### Operation as a flow meter

1.  In the menu 'calibration' calibrate the 'quantity' - see *Chapter 8.4.3.2 Calibrate "quantity" on page 38*
2.  Check whether the displayed values are plausible.

### Function "transmit flow value Q"

(for identity code characteristic "signal output" "1")

1. ➤ Set up the desired values under 'Settings → Current output → Signal current' - see [Chapter 8.4.2.3 "Current output" menu](#) on page 29.
2. ➤ Check whether the displayed values are plausible.

(for identity code characteristic "signal output" "4")

1. ➤ Under 'Set-up → Current output' set to 'controlled pump'.
2. ➤ Set the control module delta<sup>®</sup> according to the supplementary operating conditions and check whether everything functions as desired.

(for identity code characteristic "signal output" "2")

1. ➤ Set up the desired values under 'Settings → Counter output → Pulse/frequency → Signal output' - see [Chapter 8.4.2.2 "Counter output" menu](#) on page 27.
2. ➤ Check whether the displayed values are plausible.

### Function "transmit error signal"

(for identity code characteristic "signal output" "1" and "3")

1. ➤ Under 'set-up → current output → error current' set the desired error result and set the 'error current'.
2. ➤ Cause the error to occur and check whether everything functions as desired.

(for identity code characteristic "signal output" "2" and "3")

1. ➤ Under 'set-up → counter output → puls/freq. → error output' set the desired error result.
2. ➤ Cause the error to occur and check whether everything functions as desired.

## 10 Maintenance, repair and disposal



### **WARNING!**

#### **Danger from chemical residues**

There is normally chemical residue in the measurement pipe and housing after operation. This chemical residue could be hazardous to people.

- It is mandatory that the safety information relating to the "Storage, transport and unpacking" chapter is read before shipping or transporting the unit.
- Thoroughly clean the measurement pipe and the housing to remove chemicals and dirt. Adhere to the safety data sheet for the feed chemical.

### 10.1 Maintenance

Interval	Maintenance work
Regularly	Check whether the correct flow value is displayed. If this is not the case, recalibrate the flow - see chapter "calibrate".
	If stroke feedback is used: Adjust the stroke length with the metering pump running and set just above the programmed upper limit - the flow identifier at the pump should no longer flash. Adjust the stroke length with the metering pump running and set just below the programmed lower limit - the flow identifier at the pump should no longer flash. If this is not the case, check for the cause and as necessary readjust the DulcoFlow® - see <a href="#">Chapter 8.4.3.1 'Calibrate "stroke feedback" on page 31</a>
	If stroke feedback is used: Check whether the stroke feedback LED (right-hand side of the device) illuminates in time with the strokes. If this is not the case, check for the cause and rectify as necessary.
	Check whether feed chemical is coming out.
	If necessary, carefully wipe the device with a soft cloth and soapy water.

### 10.2 Repairs

Only ProMinent of customer service authorised by ProMinent may repair the DulcoFlow® flow meter.

### 10.3 Disposal



#### CAUTION!

#### Environmental hazard due to electronic waste

There are electronic components in the device, which can have a toxic effect on the environment.

- Separate the electronic components from the remaining parts.
- Observe the current applicable regulations in your country.



## 11 Troubleshooting



### **WARNING!**

#### **Warning of dangerous or unknown feed chemical**

Should a dangerous or unknown feed chemical be used: It may escape from the hydraulic components during maintenance work.

- Before maintenance work, take appropriate protective measures (safety glasses, safety gloves, ...). Observe the safety data sheet for the feed chemical.
- Drain and flush the liquid end of the metering pump before working on it.

### 11.1 DulcoFlow® error

#### Faults with error messages

The left device LED lights up red if an error exists.

Fault description	Cause	Remedy
Bubbles detected	There are too many bubbles or particles in the feed chemical.	Avoid bubbles or particles in the feed chemical.

#### Warning with error message

The left device LED lights up orange if a warning exists.

Fault description	Cause	Remedy
$Q(\text{Hz}) > Q_{\text{max}}$	Flow value Q has exceeded the pre-specified upper limit for the counter output.	Identify and rectify the reason for this on the system or DulcoFlow®.
$Q(\text{Hz}) < 0$	Flow value Q has undershot the pre-specified lower limit for the counter output.	Identify and rectify the reason for this on the system or DulcoFlow®.
$Q(\text{mA}) > Q_{\text{max}}$	Flow value Q has exceeded the pre-specified upper limit for the current output.	Identify and rectify the reason for this on the system or DulcoFlow®.
$Q(\text{mA}) < Q_{\text{min}}$	Flow value Q has undershot the pre-specified lower limit for the current output.	Identify and rectify the reason for this on the system or DulcoFlow®.



#### **LED signals**

*For further information about LED signals, see the "Settings" chapter.*

## 11.2 Pump error in connection with DulcoFlow®



To return the pump to operating status after one of the following errors, press key [P].

In the event of an error an LED lights up red and the flow identifier flashes.

Fault description	Cause	Remedy
The pump stops during priming.	Due to air in the liquid end, the DulcoFlow® has not output an acknowledge pulse.	During priming pull out the cable to the DulcoFlow® out - the function "Flow" is disabled while the cable is out.
The pump stops during DulcoFlow® set-up.	The DulcoFlow® has emitted too few sequential acknowledge pulses.	Press key [P].
The pump stops while running.	There is air in the liquid end, gaseous feed chemical.	<ul style="list-style-type: none"> <li>■ Pull out the cable to the DulcoFlow® from the pump.</li> <li>■ Bleed the liquid end.</li> <li>■ Plug the cable to the DulcoFlow® into the socket on the pump.</li> <li>■ Increase the number of acknowledge pulses in the pump's menu.</li> </ul>

## Troubleshooting

Fault description	Cause	Remedy
	There is air in the liquid end, the chemical feed container is empty.	<ul style="list-style-type: none"> <li>■ Fill the metering tank.</li> <li>■ Pull out the cable to the DulcoFlow® from the pump.</li> <li>■ Bleed the liquid end.</li> <li>■ Plug the cable to the DulcoFlow® into the socket on the pump.</li> </ul>
	Gas is present in the dosing head - leaks in the path between the chemical feed container and the DulcoFlow®.	<ul style="list-style-type: none"> <li>■ Repair the leak.</li> <li>■ Pull out the cable to the DulcoFlow® from the pump.</li> <li>■ Bleed the liquid end.</li> <li>■ Plug the cable to the DulcoFlow® into the socket on the pump.</li> </ul>
	Blockage between the DulcoFlow® and metering tank	<ul style="list-style-type: none"> <li>■ Clear the blockage.</li> <li>■ Pull out the cable to the DulcoFlow® from the pump.</li> <li>■ Bleed the liquid end.</li> <li>■ Plug the cable to the DulcoFlow® into the socket on the pump.</li> </ul>
	The stroke adjustment dial is mis-set	- see metering pump operating instructions
	The feed chemical viscosity is too high	- see metering pump operating instructions

### 11.3 All Other Faults

#### All other faults:

Inform your customer service department or your ProMinent branch.

## 12 Technical Data

### Performance Data

Data	Value	Unit
Smallest measurable stroke volume, pulsing approx.	0.03	mL/stroke
Largest measurable stroke volume, pulsing approx.	10.00	mL/stroke
Accuracy over at least 100 strokes:	± 2	%*

\* relative to the measured value

### Electrical data

Data	Value	Unit
Stroke feedback, output**:	1	Contact/stroke
Frequency output**:	0 ... 10 000	Hz
Current output, max. load:	400	Ω
Degree of protection:	IP 65	
Supply voltage:	100...230	V AC
Power consumption	5	W
Mains supply frequency:	50/60	Hz

\*\* Open collector. \*\* Rectangular pulses; pulse: Pause = 1 : 1.

At frequencies below 10 Hz: The pulse length is fixed at 20 ms and the pulse interval varies with the signal to be emitted.

### Media requirements

Material compatibility with: PVDF, seal material

Data	Value	Unit
Medium pressure:	1.5...16	bar
Medium temperature:	-10...+45	°C
Sound pressure level:	1000 ... 2500	m/s

---

## Technical Data

---

### Ambient conditions

Data	Value	Unit
Minimum storage and transport temperature	-10	°C
Maximum storage and transport temperature	+50	°C
Ambient temperature during operation, min.	-10	°C
Ambient temperature during operation, max.	+50	°C
Maximum air humidity *	95	% rel. humidity

\* non-condensing

### Materials

Component	Material
Measurement pipe	PVDF
Seals, hydraulic	- see "Identity code"
Housing	PPE+GF20
Screws, etc.	A2
Electronics	Electronic components

### Hose connection nominal widths

- see "Identity code"

**Compatibility for flow measurement**

Type	Pumps
05	Beta, gamma/ L: 1000 - 0413/0713 gamma/ X: 1000 - 0414/0715 (with the exception of 0220) delta: 1608 - 1612
08	Beta, gamma/ L: 1005/1605 - 0420 gamma/ X: 1604 - 0224 delta: 1020 - 0450 Sigma/ 1

13 Dimensions sheet

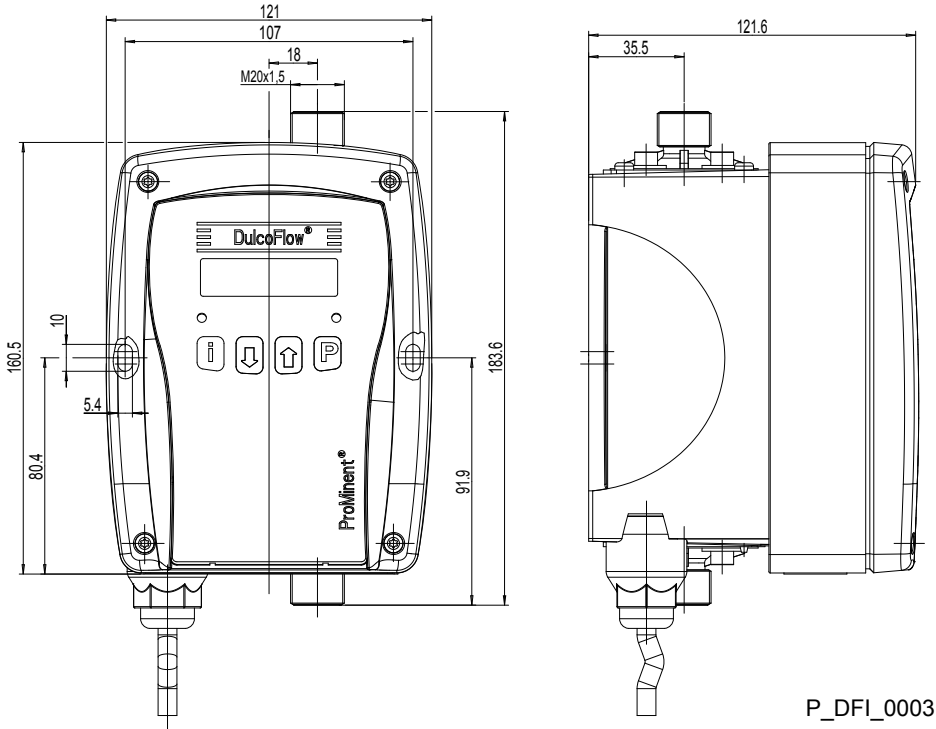

P\_DFI\_0003

Fig. 14: Dimensional drawing DulcoFlow® - dimensions in mm



## 14 Factory settings

### DulcoFlow® DFMa factory settings

Parameter	Value
<b>Settings</b>	
Measured variable	Volume
Unit of density	g/mL
Density	1.0
Volume unit	mL
Flow unit	L/h
Flow damping	10.00 s
Counter output	Stroke feedback
K factor unit	1/mL
K factor	1000
Error output	off
Open collector	NPN
Current output	4...20 mA
Flow unit	mL/h
0/4 mA value	0
20 mA value	1000
Error current	off
Sensitivity	Normal
Pump type	Solenoid meter. pump
Current output damping	10.00 s
Pump type	Solenoid meter. pump
<b>Calibration</b>	
Correction factor	100 %

Parameter	Value
Stroke volume	1 ml
Plus tolerance	100 %
Minus tolerance	-100 %
Upper limit	2 mL
Lower limit	0 mL
Language	German

### 15 EC Declaration of Conformity

In accordance with DIRECTIVE 2006/42/EC OF THE EUROPEAN PARLIAMENT AND OF THE COUNCIL, Appendix I, BASIC HEALTH AND SAFETY REQUIREMENTS, section 1.7.4.2. C.

We,

- ProMinent Dosiertechnik GmbH
- Im Schuhmachergewann 5 - 11
- D - 69123 Heidelberg,

hereby declare that the product specified in the following, complies with the relevant basic health and safety requirements of the EC Directive, on the basis of its functional concept and design and in the version distributed by us. Any modification to the product not approved by us will invalidate this declaration.

#### Extract from the EC Declaration of Conformity

Designation of the product:	DulcoFlow ultrasonic flow meter
Product type:	DFMa...
Serial number:	see nameplate on the unit
Relevant EC directives:	EC Low Voltage Directive (2006/95/EC) EC EMC Directive (2004/108/EC)
Harmonised standards applied, in particular:	EN 60335-1, EN 61010-1 EN 55011, EN 61000-6-1/2/3/4, EN 61326-1
Date:	28.01.2013

The EC Declaration of Conformity is available to download on our homepage.

# 16 Decontamination declaration

ProMinent®

## Declaration of Decontamination

(see download: [www.prominent.com](http://www.prominent.com))

Because of legal regulations and for the safety of our employees and operation equipment, we need the „declaration of decontamination“, with your signature, before your order can be handled.  
**Please make absolutely sure to include it with the shipping documents, or – even better – attach it to the outside of the packaging.**

Please return your products to:

Type of instrument / sensor: \_\_\_\_\_ Serial number: \_\_\_\_\_  
 Gerätetyp: \_\_\_\_\_ Seriennummer: \_\_\_\_\_

Process data: Temperature: \_\_\_\_\_ [°C] Pressure: \_\_\_\_\_ [bar]  
 Prozessdaten: Temperatur: \_\_\_\_\_ Druck: \_\_\_\_\_

Mediums and warnings:  
 Warnhinweise zum Medium:



	Medium/ Concentration Medium/ Konzentration	Identifi- cation CAS No.	flammable entzünd- lich	toxic giftig	corrosive ätzend	harmful/ irritant gesundheitss- chädlich/reizend	other* sonstiges*	harmless unbedenklich
Process medium Medium im Prozess								
Medium for process- cleaning Medium zur Prozessreinigung								
Returned part cleaned with Medium zur Endreinigung								

\* explosive; oxidising; dangerous for the environment; biological risk; radioactive  
 \* explosiv; brandfördernd; umweltgefährlich; biogefährlich; radioaktiv

Please tick should one of the above be applicable, include security sheet and, if necessary, special handling instructions.

Reason for return:

Company data:

Company: \_\_\_\_\_ Phone number: \_\_\_\_\_  
 Contact person: \_\_\_\_\_ Fax: \_\_\_\_\_  
 Street: \_\_\_\_\_ E-Mail: \_\_\_\_\_  
 Address: \_\_\_\_\_ Your order No: \_\_\_\_\_

“We hereby certify that the returned parts have been carefully cleaned. To the best of our knowledge they are free from any residues in dangerous quantities.”

Place, date \_\_\_\_\_ Company stamp and legally binding signature \_\_\_\_\_

## 17 Index

### A

About this product	7
Adjustment mode	26
Ambient conditions	54
Applied harmonised standards	58
Assembly	14

### B

BL	44
Bubbles	29

### C

Calibration	31
Capacity cable Ck	18, 20
Check display variables	23
Checking	23
Collector resistance Rc	18, 20
Collector resistance Rc, minimum level	19
Compatibility	55
Connection information	18
Continuous display	23
Control keys	21
controlled pump	20, 29
Correct and proper use	8
Correction factor	39, 40, 42
Counter output	17, 20, 27
Current output	17, 20, 29

### D

Damping	27, 29
Decontamination declaration	59
Density	26
Designation of the product	58
Dimensions sheet	56
Display	27
Disposal	47
Dosing monitor	17, 28, 45

### E

Earth	26, 35, 42
Electrical data	53
Emergency	9
Error output	28, 29
Error signal	46
Explanation of the safety information	8

### F

Fault	17, 20
Flow	17, 20
Flow diagram	29
Flow meter	45
Frequency output	18, 28
Functional description	13

### H

HW	44
Hydraulic system	16

### I

ID	44
Identity code	5
Info	44
Information in the event of an emergency	9
Input	39
Installation	14

### L

Language	44
LCD screen	21
Leads	18
LEDs	21
Limit values	34, 37

### M

Main menu	26
Maintenance	47
Mass flow	26
Materials	54
Max. cable length	17, 20
Measured values	39
Media requirements	53
Medium	53

### N

NPN	18
-----	----

### O

Open-collector output	18
Operating Menu	25
Operating menu overview	25
Operating unit	21
Operation	26

Output for controlled pump . . . . .	20	Standard signal output (mA) . . . . .	17, 20
Overview of equipment . . . . .	12	Start up . . . . .	45
<b>P</b>		Storage . . . . .	11
Performance Data . . . . .	53	Stroke feedback . . . . .	17, 28, 31
PNP . . . . .	18	Supplementary information . . . . .	2
Pull-up resistance . . . . .	19, 20	SW . . . . .	44
pulse/frequency output . . . . .	28	<b>T</b>	
Pump type . . . . .	31	Technical Data . . . . .	53
<b>Q</b>		Tolerances . . . . .	33, 36
Qualification of personnel . . . . .	10	Transport . . . . .	11
Quantity . . . . .	38	Troubleshooting . . . . .	49
<b>R</b>		<b>U</b>	
Relevant EC directives . . . . .	58	Units . . . . .	27
Repair . . . . .	47	<b>V</b>	
<b>S</b>		Volume . . . . .	26, 31, 40
Safety chapter . . . . .	8	Volume flow . . . . .	26
Sensitivity . . . . .	31	<b>W</b>	
Serial number . . . . .	58	Warning sign . . . . .	8
Service . . . . .	31	Wiring Diagram . . . . .	18
Set up . . . . .	21	<b>Z</b>	
Setpoint . . . . .	33, 36	Zero set . . . . .	43
Settings . . . . .	26		
Slope rate . . . . .	20		
SN . . . . .	44		

---

---

---

---



ProMinent GmbH  
Im Schuhmachergewann 5-11  
69123 Heidelberg  
Germany  
Telephone: +49 6221 842-0  
Fax: +49 6221 842-612  
email: [info@prominent.com](mailto:info@prominent.com)  
Internet: [www.prominent.com](http://www.prominent.com)

985702, 7, en\_GB