

# Operating instructions

## Solenoid Metering Pump

### gamma/ L, GALa



Please carefully read these operating instructions before use! · Do not discard!  
The operator shall be liable for any damage caused by installation or operating errors!  
Technical changes reserved.

ProMinent Dosiertechnik GmbH  
Im Schuhmachergewann 5-11  
D-69123 Heidelberg  
Telephone: +49 6221 842-0  
Fax: +49 6221 842-617  
email: [info@prominent.com](mailto:info@prominent.com)  
Internet: [www.prominent.com](http://www.prominent.com)

987612, 2, en\_GB

## Supplementary information



Fig. 1: Please read!

Read the following supplementary information in its entirety! Should you already know this information, you have an even greater need of the Operating Instructions.

The following are highlighted separately in the document:

- Enumerated lists



Instructions

⇒ Outcome of the instructions

## Information



*This provides important information relating to the correct operation of the device or is intended to make your work easier.*

## Safety notes

Safety notes are identified by pictograms - see Safety Chapter.

## General user instructions

Two sets of operating instructions are required for the safe, correct and proper operation of the metering pumps: The product-specific operating instructions and the "General Operating Instructions for ProMinent® Solenoid Metering Pumps".

Both sets of operating instructions are only valid when read together.

Please read these operating instructions carefully before use! Do not discard!

## State the identity code and serial number

Please state identity code and serial number, which you can find on the nameplate when you contact us or order spare parts. This enables the device type and material versions to be clearly identified.

## General non-discriminatory approach

In order to make it easier to read, this document uses the male form in grammatical structures but with an implied neutral sense. It is aimed equally at both men and women. We kindly ask female readers for their understanding in this simplification of the text.

# Table of contents

<b>1</b>	<b>Identity code</b> .....	<b>6</b>
<b>2</b>	<b>About this pump</b> .....	<b>8</b>
<b>3</b>	<b>Safety chapter</b> .....	<b>9</b>
<b>4</b>	<b>Storage, transport and unpacking</b> .....	<b>14</b>
<b>5</b>	<b>Overview of equipment and control elements</b> .....	<b>16</b>
	5.1 Overview of equipment.....	16
	5.2 Control elements.....	17
	5.2.1 Key functions.....	17
	5.2.2 Stroke length adjustment knob.....	18
	5.2.3 Control elements.....	18
<b>6</b>	<b>Functional description</b> .....	<b>20</b>
	6.1 Liquid End.....	20
	6.2 Drive Unit.....	20
	6.3 Capacity.....	20
	6.4 Self-Bleeding.....	20
	6.5 Functional description of control.....	20
	6.5.1 Operating modes, functions, options.....	20
	6.5.2 Function and fault indicator.....	22
	6.5.3 Hierarchy of operating modes, functions and fault statuses.....	22
<b>7</b>	<b>Assembly</b> .....	<b>23</b>
<b>8</b>	<b>Installation, hydraulic</b> .....	<b>24</b>
	8.1 Install hose lines.....	25
	8.1.1 Installation for metering pumps without bleed valve.....	25
	8.1.2 Installation for metering pumps with bleed valve.....	27
	8.1.3 Installation for metering pumps with self-bleeding (SEK type).....	28
<b>9</b>	<b>Installation, electrical</b> .....	<b>30</b>
	9.1 Supply voltage connector.....	31
	9.2 Description of the sockets.....	32
	9.2.1 "External control" terminal.....	32
	9.2.2 "Level Switch" terminal.....	33
	9.2.3 "Dosing monitor" terminal.....	33
	9.2.4 Relay.....	34
<b>10</b>	<b>Adjustment</b> .....	<b>36</b>
	10.1 Basic principles of pump adjustment.....	36
	10.2 Checking adjustable values.....	37
	10.3 Changing to adjustment mode.....	37
	10.4 Operating mode selection (MODE menu).....	38
	10.5 Operating mode settings (SET menu).....	39
	10.5.1 "Manual" operating mode settings.....	39
	10.5.2 "Analog" operating mode settings (ANALG menu).....	39
	10.5.3 "Contact" operating mode settings (CNTCT menu).....	42
	10.5.4 "Batch" operating mode settings (BATCH menu).....	44
	10.6 Programmable function settings (SET menu).....	44
	10.6.1 "Calibrate" function settings (CALIB menu).....	45
	10.6.2 "Pressure ratings" function settings (PRESS menu).....	46
	10.6.3 "Auxiliary frequency" function settings (AUX menu).....	47
	10.6.4 "Flow" function settings (FLOW menu).....	47
	10.7 Setting the code (CODE menu).....	47
	10.8 Deleting the total number of strokes or total litres (CLEAR window).....	48

<b>11</b>	<b>Operation.....</b>	<b>49</b>
	11.1 Manual operation.....	49
	11.2 Remote operation.....	51
<b>12</b>	<b>Maintenance.....</b>	<b>52</b>
<b>13</b>	<b>Repairs.....</b>	<b>54</b>
	13.1 Cleaning valves.....	54
	13.2 Replacing the metering diaphragm.....	56
<b>14</b>	<b>Troubleshooting.....</b>	<b>60</b>
	14.1 Faults without a fault alert.....	60
	14.2 Faults with error message.....	60
	14.2.1 Fault alerts.....	60
	14.2.2 Warning Alerts.....	61
	14.3 All Other Faults.....	62
<b>15</b>	<b>Decommissioning.....</b>	<b>63</b>
<b>16</b>	<b>Technical data.....</b>	<b>65</b>
	16.1 Performance data.....	65
	16.2 Accuracy.....	66
	16.2.1 Standard Liquid End.....	66
	16.2.2 Self-Bleeding Liquid End.....	66
	16.3 Viscosity.....	66
	16.4 Material specifications.....	67
	16.5 Electrical data.....	67
	16.6 Temperatures.....	67
	16.7 Climate.....	68
	16.8 Protection class and Safety Requirements.....	68
	16.9 Compatibility.....	68
	16.10 Sound pressure level.....	69
	16.11 Shipping weight.....	69
<b>17</b>	<b>EC Declaration of Conformity.....</b>	<b>70</b>
<b>18</b>	<b>Operating / adjustment overview.....</b>	<b>72</b>
<b>19</b>	<b>Continuous displays.....</b>	<b>74</b>
<b>20</b>	<b>Index.....</b>	<b>75</b>

# 1 Identity code

Product range gamma/ L				
GALa	Type	Performance		
		bar	l/h	
	1000	10	0.74	Solenoid Ø 70 / M70
	1601	16	1.1	
	1602	16	2.1	
	1005	10	4.4	
	0708	7	7.1	
	0413	4	12.3	
	0220	2	19.0	
	1605	16	4.1	Solenoid Ø 85 / M85
	1008	10	6.8	
	0713	7	11.0	
	0420	4	17.1	
	0232	2	32.0	
		<b>Material version</b>		
	PPE	Polypropylene / EPDM		
	PPB	Polypropylene / FPM		
	NPE	Clear acrylic / EPDM		
	NPB	Clear acrylic / FPM		
	PVT	PVDF / PTFE		
	TTT	PTFE/PTFE		
	SST	Stainless steel 1.4571 / PTFE		
		<b>Dosing head version</b>		
	0	without bleed valve, without valve spring only for NP, TT and SS		
	1	without bleed valve, with valve spring only for NP, TT and SS		
	2	with bleed valve, without valve spring only for PP, NP, PV, not for type 0232		
	3	with bleed valve, with valve spring only for PP, NP, PV, not for type 0232		
	4	without bleed valve, with valve spring for more highly viscous media		
	9	self-bleeding only for PP and NP, not for types 1000 and 0232		
		<b>Hydraulic connector</b>		
	0	Standard connector in line with technical data		
	5	Connector for 12/6 tube, discharge side only		
	9	Connector for 10/4 tube, discharge side only		
		<b>Design</b>		
	0	with ProMinent logo		
		<b>Power supply</b>		
	U	100 - 230 V, ±10 %, 50/60 Hz		
	M	12 ... 24 V DC (M 70 only)		
	N	24 V DC (M 85 only)		

Product range gamma/ L						
					P	24 V AC
						<b>Cable and plug</b>
					A	2 m European
					B	2 m Swiss
					C	2 m Australian
					D	2 m USA
					1	2 m open end
						<b>Relay</b>
					0	No relay
					1	fault indicating relay (NC) (change-over relay)
					3	fault indicating relay (NO) (change-over relay)
					4	as 1 + pacing relay, (per 1x ON)
					5	as 3 + pacing relay, (per 1x ON)
						<b>Accessories</b>
					0	No accessories
					1	with foot and injection valve, 2 m PVC suction line, 5 m PE metering line, only for PP, PC and NP
					2	as 0 + calibration cylinder
					3	as 1 + calibration cylinder
						<b>Control versions</b>
					0	Manual + external 1:1
					1	Manual + external with pulse control
					2	Manual + external 1:1 + analog current
					3	Manual + external with pulse control + analog current
					4	as 0 + timer
					5	as 3 + timer
					P	as 3 + PROFIBUS®
						<b>Access code</b>
					0	no access code
					1	with access code
						<b>Dosing monitor</b>
					0	Input for pulses
					1	Input for continuous contact
						<b>Pause / level</b>
					0	Pause N/C, level N/C

## 2 About this pump

Pumps in the ProMinent gamma/ L product range are microprocessor-controlled solenoid metering pumps with the following characteristics:

- The capacity can be displayed in l/h or gal/h respectively (in a calibrated state or in strokes/min)
- The stroke length is infinitely adjustable and is shown in the LCD display
- The stroke rate can be set digitally precisely and is shown in the LCD display
- The rated pressure of the gamma/ L can be adapted by pressure ratings to a system
- Two pumps can be actuated differently by means of the same standard signal
- Large illuminated LCD display

The hydraulic parts of the gamma/ L are identical to those of the Beta®.



### 3 Safety chapter



#### Explanation of the safety information

The following signal words are used in these operating instructions to identify different severities of a hazard:

Signal word	Meaning
<b>WARNING</b>	Denotes a possibly hazardous situation. If this is disregarded, you are in a life-threatening situation and this can result in serious injuries.
<b>CAUTION</b>	Denotes a possibly hazardous situation. If this is disregarded, it could result in slight or minor injuries or material damage.

#### Warning signs denoting different types of danger

The following warning signs are used in these operating instructions to denote different types of danger:

Warning signs	Type of danger
	Warning – automatic start-up.
	Warning – high-voltage.
	Warning – danger zone.

#### Correct and proper use

- The pump may only be used to meter liquid metering chemicals.
- The pump may only be started up after it has been correctly installed and commissioned in accordance with the technical data and specifications contained in the operating instructions.
- Observe the general limitations with regard to viscosity limits, chemical resistance and density - see also ProMinent® resistance list (In the product equipment catalogue or at [www.prominent.com](http://www.prominent.com)).
- Any other uses or modifications are prohibited.
- The pump is not intended for the metering of gaseous media or solids.
- The pump is not intended for the metering of explosive media.
- The pump is not intended for operation in hazardous locations.
- The pump is not intended for exterior applications without use of suitable protective equipment.
- The pump should only be operated by trained and authorised personnel, see the following "Qualifications" table.
- You are obliged to observe the information contained in the operating instructions at the different phases of the device's service life.

### Safety notes



#### **WARNING!**

##### **Warning about personal and material damage**

The pump can start to pump, as soon as it is connected to the mains voltage.

- Install an emergency cut-off switch in the pump power supply line or integrate the pump in the emergency cut-off management of the system.



#### **WARNING!**

##### **Danger of electric shock**

A mains voltage may exist inside the pump housing.

- If the pump housing has been damaged, you must disconnect it from the mains immediately. It may only be returned to service after an authorised repair.



#### **WARNING!**

##### **Fire danger**

Combustible media may only be transported using stainless steel dosing heads. In exceptional cases where this is not possible, PTFE with carbon can be used, whereby our TT\_ versions are manufactured from this conducting plastic. Here, the operator is urged to take special care due to the low mechanical strength.



#### **WARNING!**

##### **Warning of dangerous or unknown feed chemical**

Should a dangerous or unknown feed chemical be used: It may escape from the hydraulic components when working on the pump.

- Take appropriate protective measures before working on the pump (e.g. safety glasses, safety gloves, ...). Observe the safety data sheet for the feed chemical.
- Drain and flush the liquid end before working on the pump.



#### **WARNING!**

##### **Danger from hazardous substances!**

Possible consequence: Fatal or very serious injuries.

Please ensure when handling hazardous substances that you have read the latest safety data sheets provided by the manufacture of the hazardous substance. The actions required are described in the safety data sheet. Check the safety data sheet regularly and replace, if necessary, as the hazard potential of a substance can be re-evaluated at any time based on new findings.

The system operator is responsible for ensuring that these safety data sheets are available and that they are kept up to date, as well as for producing an associated hazard assessment for the workstations affected.

**CAUTION!****Warning of feed chemical spraying around**

Feed chemical can spray out of the hydraulic components if they are manipulated or opened due to pressure in the liquid end and adjacent parts of the system.

- Disconnect the pump from the mains power supply and ensure that it cannot be switched on again by unauthorised persons.
- Depressurise the system before commencing any work on hydraulic parts.

**CAUTION!****Warning of feed chemical spraying around**

An unsuitable feed chemical can damage the parts of the pump contacted by the chemical.

- Take into account the resistance of the materials which will come into contact with the chemical when selecting the feed chemical - see the ProMinent product catalogue or under [www.prominent.com](http://www.prominent.com).

**CAUTION!****Warning of feed chemical spraying around**

The metering pump can generate a multiple of its rated pressure. If a discharge line is blocked, hydraulic parts may burst.

- Correctly install a relief valve in the discharge line downstream of the metering pump.

**CAUTION!****Danger of personnel injury and material damage**

The use of untested third party parts can result in personnel injuries and material damage.

- Only fit parts to metering pumps, which have been tested and recommended by ProMinent.

**CAUTION!****Danger from incorrectly operated or inadequately maintained pumps**

Danger can arise from a poorly accessible pump due to incorrect operation and poor maintenance.

- Ensure that the pump is accessible at all times.
- Adhere to the maintenance intervals.

**CAUTION!****Danger from incorrect metering**

Should a different liquid end size be fitted, this will change the metering behaviour of the pump.

- Have the pump reprogrammed in the works.



**CAUTION!**

**Warning of illegal operation**

Observe the regulations that apply where the unit is to be installed.

**Fixed separating protective equipment**

- Dosing head
- Housing
- Hood (houses the control elements)

The dosing head may only be removed by the customer in accordance with the "Repair" chapter.

The housing and the hood may only be removed by ProMinent customer service department.

**Information in the event of an emergency**

In an emergency, either pull out the mains plug or press the customer installed emergency-off switch or disconnect the pump according to the emergency-off management for your system!

If feed chemical escapes, also depressurise the hydraulic system around the pump. Adhere to the safety data sheet for the feed chemical.

**Qualification of personnel**

Activity	Qualification level
Storage, transport, unpacking	Instructed person
Assembly, installation of hydraulic system	Technical personnel, service
Installation, electrical	Electrical technician
Operation	Instructed person
Maintenance, repair	Technical personnel, service
Decommissioning, disposal	Technical personnel, service
Troubleshooting	Technical personnel, electrical technician, instructed person, service

**Explanation of the terms:**

**Technical personnel**

A qualified employee is deemed to be a person who is able to assess the tasks assigned to him and recognise possible dangers based on his/her technical training, knowledge and experience, as well as knowledge of pertinent regulations.

Note:

A qualification of equal validity to a technical qualification can also be gained by several years employment in the relevant work area.

**Electrical technician**

Electrical technicians are deemed to be people, who are able to complete work on electrical systems and recognize and avoid possible dangers independently based on their technical training and experience, as well as knowledge of pertinent standards and regulations.

Electrical technicians should be specifically trained for the working environment in which they are employed and know the relevant standards and regulations.

Electrical technicians must comply with the provisions of the applicable statutory directives on accident prevention.

**Instructed person**

An instructed person is deemed to be a person who has been instructed and, if required, trained in the tasks assigned to him/her and possible dangers that could result from improper behaviour, as well as having been instructed in the required protective equipment and protective measures.

**Service**

Customer Service department refers to service technicians, who have received proven training and have been authorised by ProMinent or ProMaqua to work on the system.

**Sound pressure level**

Sound pressure level LpA < 70 dB in accordance with EN ISO 20361:2010-10

at maximum stroke length, maximum stroke rate, maximum back pressure (water)

## 4 Storage, transport and unpacking

### Safety notes



**WARNING!**

The transporting of pumps which have been used with radioactive feed chemicals is forbidden!

They will also not be accepted by ProMinent!



**WARNING!**

Only return the metering pump for repair in a cleaned state and with a flushed liquid end - refer to the section on decommissioning!

Only send metering pumps with a filled in Decontamination Declaration form. The Decontamination Declaration constitutes an integral part of an inspection / repair order. A unit can only be inspected or repaired if a Decontamination Declaration is submitted that has been completed correctly and in full by an authorised and qualified person on behalf of the pump operator.

The "Decontamination Declaration" form can be found in the General Operating Instructions or under [www.prominent.com](http://www.prominent.com).



**CAUTION!**

**Danger of material damage**

The device can be damaged by incorrect or improper storage or transportation!

- The unit should only be stored or transported in a well packaged state - preferably in its original packaging.
- The packaged unit should also only be stored or transported in accordance with the stipulated storage conditions.
- The packaged unit should be protected from moisture and the ingress of chemicals.

Personnel:  Technical personnel

### Ambient conditions

Data	Value	Unit
Minimum storage and transport temperature	-10	°C
Maximum storage and transport temperature	+50	°C
Air humidity	< 95	% rel. humidity*

\* non-condensing

### Scope of supply

Compare the delivery note with the scope of supply:

- Metering pump with mains power cable
- Connector kit for tube/pipe connection
- Product-specific operating instructions with EC Declaration of Conformity
- CD with order information, exploded diagrams, performance diagrams and data sheets
- Optional accessories if ordered

## 5 Overview of equipment and control elements

### 5.1 Overview of equipment

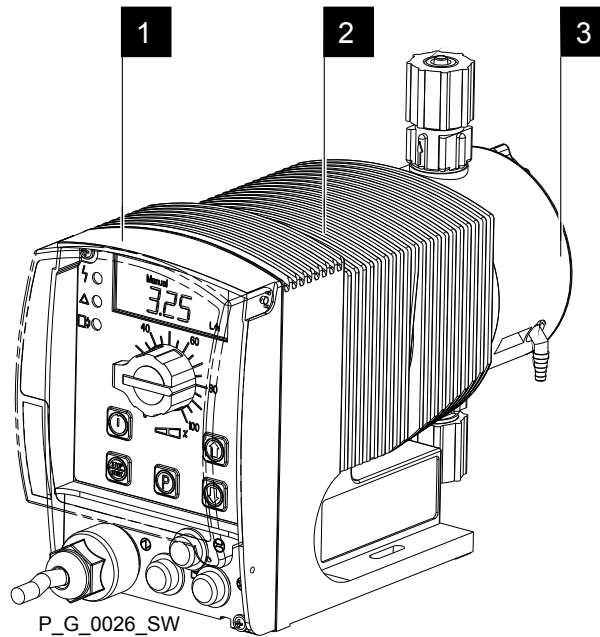

Fig. 2: Overview of equipment, total

- 1 Control unit
- 2 Drive unit
- 3 Liquid end

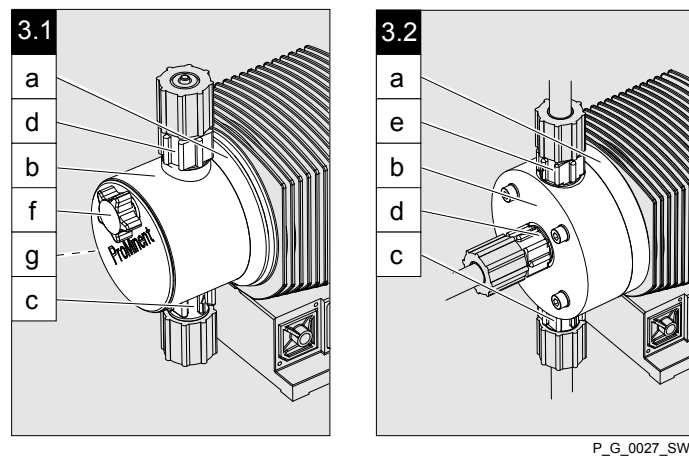

Fig. 3: 3.1 Liquid end with bleed valve, 3.2 Self-bleeding liquid end (SEK)

- a Backplate
- b Dosing head
- g Suction valve
- d Discharge valve
- e Bleed valve, self-bleeding
- f Bleed valve
- c Bypass hose nozzle, concealed



## 5.2 Control elements

### Control elements, overview

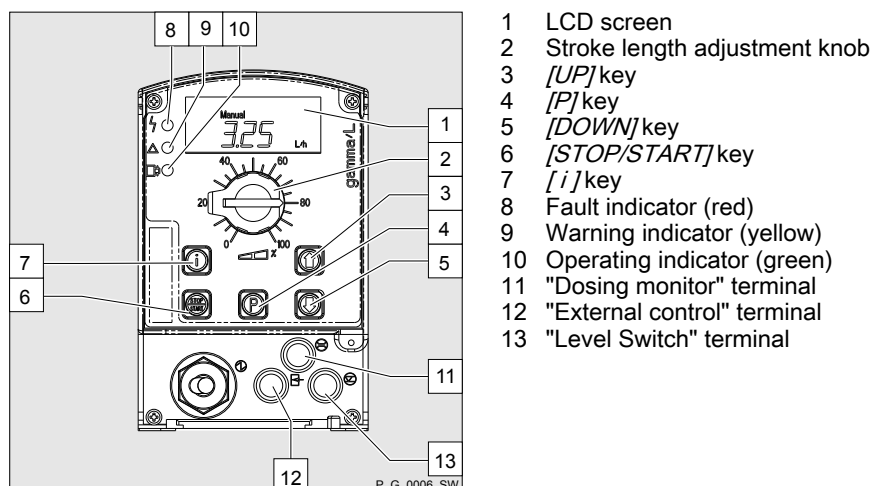

Fig. 4

### 5.2.1 Key functions

Key	Application	In continuous displays (operation)	In adjustment mode (set up)
[STOP/START]	Pressed briefly	Stop pump,	Stop pump,
		start pump	start pump
[P]	Pressed briefly	Start batch (only in 'Batch' operating mode), acknowledge fault	Confirm entry - jump to next menu point or to continuous display
	Pressed for 2 s	Change to adjustment mode	-
	Pressed for 3 s	-	Jump to continuous display
	Pressed for 10 s	Display software version	-
	Pressed for 15 s	Load factory settings (calibration)	-
[i]	Pressed 1x	Change between the continuous displays	Change between "Changing individual numbers" and "Changing a number"
	Pressed 2x	-	Under "change individual digits": jump to the first number
[UP], [DOWN]	Individually pressed (until 'Set' identifier appears)	Change directly changeable variables	Select another setting, change individual number or number
	Pressed simultaneously	Priming (in "Stroke rate" continuous display)	-

## 5.2.2 Stroke length adjustment knob

The stroke length can be adjusted using the stroke length adjustment knob and with it the volume per stroke.

## 5.2.3 Control elements



*Familiarise yourself with the pump control elements using the "Control elements and key functions" overview!*

### Identifiers

The LCD screen supports the operation and adjustment of the pump with different identifiers:

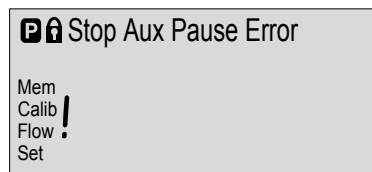

B0081

Fig. 5

The identifiers have the following meanings:

Identifiers	Meaning
<b>P</b>	The pump is in adjustment mode.
	In the continuous display: Security lock (if a code was set). In adjustment mode: Indicates entry into 'CODE' menu.
'Stop'	The pump was stopped using the [STOP/START]key.
'Aux'	The pump is currently pumping with the auxiliary rate as the stroke rate.
'Pause'	In the 'AUX' menu. The pump is in the 'AUX' menu.
'Error'	The pump was externally stopped by the "Pause" function (externally).
'Mem'	In "Contact" and "Batch" operating modes: The auxiliary function "Memory" has been set. In the 'CNTCT' or 'BATCH' menu (identifier 'Mem' flashes): The auxiliary function "Memory" can be set.
'Calib'	The pump is in the 'CALIB' menu. In the continuous display (identifier 'Calib' flashes): Deviations of the stroke length from the value to the time of calibration by more than 10 scale divisions, that is with a stroke length of 40 %, if this is set at less than 30 % or at greater than 50 %.
'Flow'	The pump is in the 'FLOW' menu.
'Set'	The pump is in the 'SET' menu.
<b>!</b>	The number of strokes achieves is higher than the maximum figures of 99999 that can be displayed in the LCD screen.



*The pump only shows the metering volume and the capacity in the calibrated state in l or l/h or in gal or gal/h.*

## 6 Functional description

### 6.1 Liquid End

The dosing process is performed as follows: The diaphragm is pressed into the dosing head; the pressure in the dosing head closes the suction valve and the feed chemical flows through the discharge valve out of the dosing head. The diaphragm is now drawn out of the dosing head; the discharge valve closes due to the negative pressure in the dosing head and fresh feed chemical flows through the suction valve into the dosing head. One cycle is completed.

### 6.2 Drive Unit

The diaphragm is driven by an electromagnet, which is controlled by an electronic controller.

### 6.3 Capacity

The capacity is determined by the stroke length and the stroke rate. The stroke length can be adjusted between 0 and 100 % using the stroke length adjustment knob. A metering volume of between 30 to 100% is reproduced as being technically sensible (SEK type: 50 - 100 %)! The stroke rate can be set using the arrow keys (not in "Analog" operating mode) within a range of 0 - 180 strokes/min.

### 6.4 Self-Bleeding

Self-bleeding liquid ends (SEK types) are capable of independent priming when a discharge line is connected and diverting existent air pockets via a bypass. During operation they are also capable of conveying away gases which are produced, independently of the operating pressure in the system. It is also possible to dose precisely in a depressurised state due to the integral back pressure valve.

## 6.5 Functional description of control

### 6.5.1 Operating modes, functions, options

#### Operating modes

The operating modes are selected via the *'MODE'* menu (dependent on the identity code, some operating modes may not be present):

***'Analog'* operating mode** (Identity code, control variant: analog). The stroke rate is controlled using an analog current signal via the "External control" terminal. Processing of the current signal can be preselected via the control unit.

***'Manual'* operating mode** The stroke rate is set manually via the control unit. 100 % corresponds to 180 strokes/min.

***'Contact'* operating mode:** This operating mode provides the option of making fine adjustments using small scaling or transfer factors. The metering can be triggered either by a pulse received via the "External control" terminal or through a contact or a semiconductor switching element. A metering quantity (batch) or a number of strokes (scaling or transfer factor 0.01 to 99.99) can be pre-selected via the control unit using the "Pulse Control" option.

**'Batch' operating mode:** This operating mode provides the option of working with large transfer factors (up to 65535). The metering can be triggered either by pressing the *[P]* key or by a pulse received via the "External control" terminal or through a contact or a semiconductor switching element. It is possible to pre-select a metering quantity (batch) or a number of strokes via the control unit.

**'BUS' operating mode** (Identity code, control variant: CANopen or PROFIBUS®) This operating mode provides the option of controlling the pump via a BUS (see "Supplementary instructions for ProMinent® gamma/ L and ProMinent Sigma versions with PROFIBUS®").

## Functions

The following functions can be selected using the SET menu:

**"Calibrate" function:** (Identity code, stroke length adjustment: Manual + calibration): The pump can also be operated in the calibrated state in all operating modes. In this case, the corresponding continuous displays can then indicate the metering volume or the capacity directly. Calibration is maintained within a stroke rate range of 0 - 180 strokes/min. The calibration is also maintained when the stroke length is altered by up to  $\pm 10\%$  scale divisions.

**"Auxiliary frequency" function:** Enables a freely selectable and programmable stroke rate to be switched on in the *'SET'* menu, which can be controlled via the "External Control" terminal. This auxiliary frequency has priority over the operating mode stroke rate settings.

**"Flow" function:** Stops the pump when the flow is insufficient, provided a dosing monitor is connected. The number of defective strokes, after which the pump is switched off, can be set in the *'SET'* menu.

The following functions are available as standard:

**"Level switch" function:** Information about the liquid/powder level in the chemical feed container is reported to the pump control. To do so, a two-stage level switch must be fitted; it is connected to the "Level switch" terminal.

**"Pause" function:** The pump can be remotely stopped via the "External Control" terminal. The "Pause" function only works via the "External Control" terminal.

The following functions are triggered by a key press:

**"Stop" function:** The pump can be stopped without disconnecting it from the mains/power supply by pressing the *[STOP/START]* key.

**"Priming" function:** Priming (short-term transport at maximum frequency) can be triggered by simultaneous pressing of the two arrow keys in the "Stroke rate" continuous display.

## Relay option

The pump has two connecting options (not with PROFIBUS® or timer):

**Option "Fault indicating relay" or "Output relay":** In the event of fault signals, warning signals or tripped level switches, the relay connects to complete an electric circuit (for alarm horns etc.). The relay can be retrofitted via a knock-out in the drive unit.

**"Fault indicating and pacing relay" option** In addition to the fault indicating relay, the pacing relay can be used to make a contact every stroke. The relay can be retrofitted via a knock-out in the drive unit.

## 6.5.2 Function and fault indicator

The operating and fault statuses are indicated by the three LED indicators and the *'Error'* identifier on the LCD screen, see also the "Troubleshooting" chapter.

### LCD screen

If a fault occurs, the identifier *'Error'* appears and an additional error message.

### LED displays

**Operating indicator (green):** The operating indicator illuminates if during pump operation there are no incoming fault or warning messages. It goes out briefly with every stroke.

**Warning indicator (yellow):** The warning indicator illuminates if the pump electronics detect a condition which may lead to a fault, e.g. "liquid level low 1st stage".

**Fault indicator (red):** The fault indicator illuminates if a fault occurs e.g. liquid level low 2nd stage".

## 6.5.3 Hierarchy of operating modes, functions and fault statuses

The different operating modes, functions and fault statuses have a different effect on if and how the pump reacts.

The following list shows the order:

1. - Priming
2. - Fault, Stop, Pause
3. - Auxiliary frequency (external frequency changeover)
4. - Manual, external contact

Comments:

re 1 - "Priming" can take place in any mode of the pump (providing it is functioning).

re 2 - "Fault", "Stop" and "Pause" stop everything apart from "Priming".

re 3 - The stroke rate of "Auxiliary rate" always has priority over the stroke rate specified by an operating mode or priority 4.

## 7 Assembly

**WARNING!****Danger of electric shock**

If water or other electrically conducting liquids penetrate into the drive housing, in any other manner than via the pump's suction connection, an electric shock may occur.

- Position the pump so that it cannot be flooded.

**CAUTION!****Danger from incorrectly operated or inadequately maintained pumps**

Danger can arise from a poorly accessible pump due to incorrect operation and poor maintenance.

- Ensure that the pump is accessible at all times.
- Adhere to the maintenance intervals.

**Capacity too low**

*The liquid end valves can be disrupted by vibrations.*

- *Secure the metering pump so that no vibrations can occur.*

**Capacity too low**

*If the valves of the liquid end do not stand vertically upwards, they cannot close correctly.*

- *Suction and discharge valves must stand vertically upwards (for self-bleeding liquid end, the bleed valve).*

- ➔ Mount the metering pump with the pump foot on a horizontal, level and load-bearing supporting surface.

## 8 Installation, hydraulic

### Safety notes



#### CAUTION!

##### Warning of feed chemical spraying around

An unsuitable feed chemical can damage the parts of the pump contacted by the chemical.

- Take into account the resistance of the materials which will come into contact with the chemical when selecting the feed chemical - see the ProMinent product catalogue or under [www.prominent.com](http://www.prominent.com).



#### CAUTION!

##### Warning of feed chemical spraying around

Pumps which are not fully installed hydraulically can eject feed chemicals from the outlet openings of the discharge valves as soon as they are connected to the mains.

- The pump must first be hydraulically installed and then electrically.
- In the event that you have failed to do so, press the *[STOP/START]* button or press the emergency-stop switch.



#### CAUTION!

##### Warning of feed chemical spraying around

Feed chemical can spray out of the hydraulic components if they are manipulated or opened due to pressure in the liquid end and adjacent parts of the system.

- Disconnect the pump from the mains power supply and ensure that it cannot be switched on again by unauthorised persons.
- Depressurise the system before commencing any work on hydraulic parts.



#### CAUTION!

##### Danger from rupturing hydraulic components

Peak loads during the dosing stroke can cause the maximum permissible operating pressure of the system and pump to be exceeded.

- The discharge lines are to be properly designed.



#### CAUTION!

##### Danger of personnel injury and material damage

The use of untested third party parts can result in personnel injuries and material damage.

- Only fit parts to metering pumps, which have been tested and recommended by ProMinent.



#### CAUTION!

##### Warning of illegal operation

Observe the regulations that apply where the unit is to be installed.



## 8.1 Install hose lines

### 8.1.1 Installation for metering pumps without bleed valve

#### Safety notes

**CAUTION!****Warning of feed chemical spraying around**

If the pipes are improperly installed, they can come loose or burst.

- Route all hose lines so they are free from mechanical stresses and kinks.
- Only use original hoses with the specified hose dimensions and wall thicknesses.
- To ensure high durability of the connections, only use clamp rings and hose nozzles that are intended for the hose diameter in question.

**CAUTION!****Danger resulting from rupturing hydraulic components**

Hydraulic components can rupture if the maximum permissible operating pressure is exceeded.

- Always maintain the maximum permissible operating pressure of all hydraulic components - please refer to the product specific operating instructions and system documentation.
- Never allow the metering pump to run against a closed shut-off device.
- Install a relief valve.

**CAUTION!****Hazardous feed chemicals can escape**

Hazardous or extremely aggressive feed chemicals can leak out when using conventional bleeding procedures with metering pumps.

- Install a bleed line with recirculation into the storage tank.

**CAUTION!****Hazardous feed chemicals can escape**

Hazardous or extremely aggressive feed chemicals can leak out in the event that the metering pump is removed from the installation.

- Shut-off valves must be installed on the metering pump's pressure and discharge sides.

**CAUTION!****Uncontrolled flowing feed chemicals**

Feed chemicals can leak through a stopped metering pump in the event of back pressure.

- For this purpose, use an injection valve or vacuum breaker.



### CAUTION!

#### Uncontrolled flowing feed chemicals

Feed chemicals can leak through the metering pump in an uncontrolled manner in the event of excessive priming pressure.

- The maximum priming pressure for the metering pump may not be exceeded - please refer to the product-specific operating instructions.



*The pipes are to be aligned in such a way as the metering pump and the liquid end can be removed from the side, if necessary.*

### Install hose lines - design PP, NP, PV, TT

1. ➤ Cut off the ends of the hoses at right angles.
2. ➤ Pull the union nut (2) and clamp ring (3) over the tube (1) - see figure Fig. 6.
3. ➤ Push the tube end (1) up to the stop over the nozzle (4). Widen it, if necessary.



*Ensure that the O-ring and flat seal (5) is properly fitted to the valve (6).*



*Used PTFE seals may never be re-used. An installation sealed in this way will not be watertight.*

*The reason for this is that this type of seal is permanently distorted when subjected to pressure.*



*In order to enable it to be distinguished from the EPDM flat seal, the FPM flat seal design PV has a dot.*

4. ➤ Place the tube (1) with the nozzle (4) onto the valve (6).
5. ➤ Clamp the hose connector: Screw the union nut (2) tight while simultaneously pressing on the tube (1).
6. ➤ Re-tighten the hose connector: Pull on the hose (1) briefly, which is fastened to the dosing head, and tighten up the union nut (2) once more.

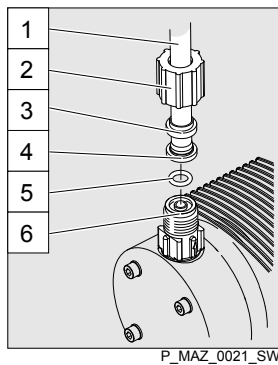

- 1 Tube
- 2 Union nut
- 3 Clamp ring
- 4 Nozzle
- 5 O-ring and flat seal
- 6 Valve

Fig. 6: Designs PP, NP, PV, TT

### Installing stainless steel pipe - design SS

1. ➔ Pull the union nut (2) and clamp rings (3, 4) over the pipe (1) with approx. 10 mm overhang - see Fig. 7.
2. ➔ Insert the pipe (1) up to the stop in the valve (5).
3. ➔ Tighten the union nut (2).

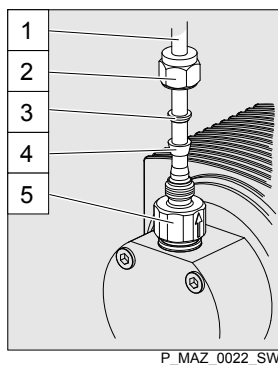

- 1 Pipe
- 2 Union nut
- 3 Rear clamp ring
- 4 Front clamp ring
- 5 Valve

Fig. 7: Design SS

### Installing hose lines - design SS



#### CAUTION!

#### Warning of feed chemical spraying around

Connections can come free in the event that hose lines are installed incorrectly on stainless steel valves.

- Only use PE or PTFE hose lines.
- In addition, insert a stainless steel support insert into the hose line.

## 8.1.2 Installation for metering pumps with bleed valve

### Safety notes



#### CAUTION!

- All of the installation and safety notes for metering pumps without bleed valves also apply.

### Installation of the return line

A return line is connected in addition to the suction and discharge lines.

1. ➔ Fasten the tube line to the return line tube nozzle or to the liquid end bleed valve. PVC tube, soft, 6x4 mm is recommended for this.
2. ➔ Feed the free end of the return line back to the storage tank.

3. ➔ Shorten the return line hose so that it cannot submerge into the feed chemical in the storage tank.

### 8.1.3 Installation for metering pumps with self-bleeding (SEK type)

#### Safety notes



#### CAUTION!

- All of the installation and safety notes for metering pumps without self-bleeding also apply.
- The maximum values for priming lift, priming pressure and the viscosity of the feed chemical may not be exceeded.
- The suction end hose line cross section may not exceed the hose line cross section of the suction valve.



#### Information about priming pressure

- *The priming pressure on the suction end must be at least equal to the return line pressure.*
- *Priming pressure in the return line restricts the bleeding function.*
- *However, operation with priming pressure in the return line and the suction end at atmospheric pressure is possible.*

#### Installation of the return line

A return line is connected in addition to the suction and discharge lines.



- *The return line is connected to the vertical valve on the upper side of the liquid end. It is labelled with a red sleeve from factory - see Fig. 8.*
- *The discharge line is connected to the vertical valve.*

1. ➔ Fasten the tube line to the return line tube nozzle or to the liquid end bleed valve. PVC tube, soft, 6x4 mm is recommended for this.
2. ➔ Feed the free end of the return line back to the storage tank.
3. ➔ SEK only: Insert the return line into the anti-kink device on the bleed valve and screw it in place until the anti-kink device engages.



*The anti-kink device prevents the return line from kinking, thereby avoiding the risk of self-bleeding system failure.*

4. ➔ Shorten the return line hose so that it cannot submerge into the feed chemical in the storage tank.

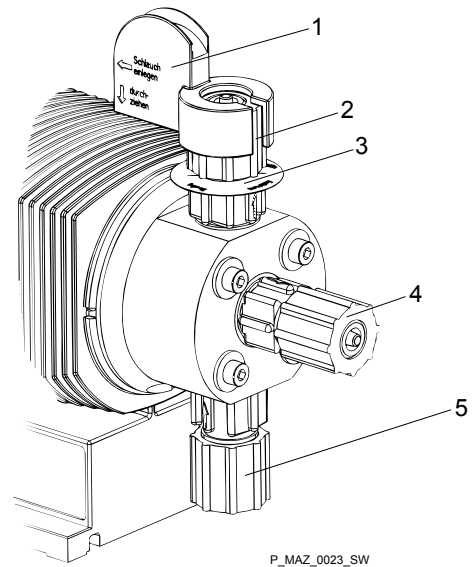

Fig. 8: SEK liquid end

- 1 Anti-kink device
- 2 Bleed valve for the return line in the storage tank, 6/4 mm
- 3 Red sleeve
- 4 Discharge valve for discharge line to injection point, 6/4 - 12/9 mm
- 5 Suction valve for suction line in storage tank, 6/4 - 12/9 mm

## 9 Installation, electrical



**WARNING!**

**Danger of electric shock**

A mains voltage may exist inside the device.

- Before any work, disconnect the device's mains cable from the mains.



**WARNING!**

**Risk of electric shock**

This pump is supplied with a grounding conductor and a grounding-type attachment plug.

- To reduce the risk of electric shock, ensure that it is connected only to a proper grounding-type receptacle.



**WARNING!**

**Risk of electric shock**

In the event of an electrical accident, the pump must be quickly disconnected from the mains.

- Install an emergency cut-off switch in the pump power supply line or
- Integrate the pump in the emergency cut-off management of the system and inform personnel of the isolating option.



**WARNING!**

**Danger of electric shock**

Incompletely installed electrical options can allow moisture into the inside of the housing.

- Knock-out openings in the pump housing must be equipped with matching modules or be sealed in a leak-tight manner.



**WARNING!**

**Danger of electric shock**

A mains voltage may exist inside the pump housing.

- If the pump housing has been damaged, you must disconnect it from the mains immediately. It may only be returned to service after an authorised repair.



**CAUTION!**

**Risk of short circuiting caused by moist pins**

No moisture must reach the pins of the PROFIBUS® jack.

- A suitable PROFIBUS® plug or protective cap must be screwed onto the PROFIBUS® jack.



**CAUTION!**

**Material damage possible due to power surges**

Should the pump be connected to the mains power supply in parallel to inductive consumers (such as solenoid valves, motors), inductive power surges can damage the controller when it is switched off.

- Provide the pump with its own contacts and supply with voltage via a contactor relay or relay.

Personnel: ■ Electrician

➔ Install the pump technically correctly and in accordance with the operating instructions and applicable regulations.

## 9.1 Supply voltage connector



**WARNING!**

**Unexpected startup is possible**

As soon as the pump is connected to the mains, the pump may start pumping and consequently feed chemical may escape.

- Prevent dangerous feed chemicals from escaping.
- If you have not successfully prevented this, immediately press the *[STOP/START]* key or disconnect the pump from mains, e.g. via an emergency cu-off switch.



**CAUTION!**

If the pump is integrated into a system: The system must be designed so that potential hazardous situations are avoided by pumps starting up automatically subsequent to unintended power interruptions.

Connect the pump to the mains/power supply using the mains cable.

### Parallel connection to inductive consumers

Should the pump be connected to the mains in parallel to inductive consumers (e.g. solenoid valves, motor), the pump must be electrically isolated when these consumers are switched off.

- Supply the pumps with voltage via a contactor relay or relay using separate contacts for the pump.
- If this is not possible then connect a varistor (part no. 710912) or an RC member, 0.22 µF / 220 Ω in parallel.

### Interference suppression aids

Product	Part no.
Varistor:	710912
RC Gate, 0.22 µF / 220 Ω:	710802

## 9.2 Description of the sockets

### 9.2.1 "External control" terminal

The "external control" socket is a five-pin panel jack. It is compatible with two- and four-conductor cables.

The "Auxiliary frequency" and "mA-output" functions can only be used with a five conductor cable.

Electrical interface for pin 1 "Pause" - pin 2 "External contact" - pin 5 "Auxiliary frequency"

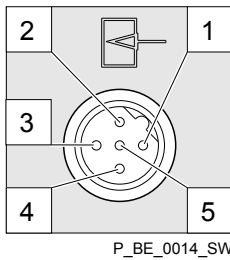

Fig. 9: Pump pin assignments

Data	Value	Unit
Voltage with open contacts	5	V
Input resistance	10	kΩ
Max. pulse frequency	25	pulse/s
Minimum pulse duration	20	ms

Control via:

- potential-free connection contact (load: 0.5 mA at 5 V) or
- Semiconductor switch (residual voltage < 0.7 V)

Electrical interface for pin 3 "mA output" (identity code characteristic "Control variant": 2 and 3)<sup>1</sup>

Data	Value	Unit
Input apparent ohmic resistance, approx.	120	Ω

<sup>1</sup> The metering pump makes its first metering stroke at approx. 0.4 mA (4.4 mA) and starts continuous operation at approx. 19.2 mA.

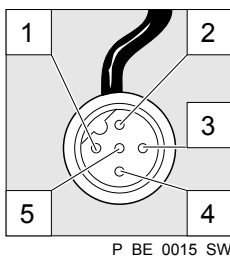

Fig. 10: Cable conductor assignments

Pin	Function	5-conductor cable	2-conductor cable
1	Pause	brown	bridged at pin 4
2	External contact	white	brown
3	mA output*	blue	-
4	Earth / GND	black	white
5	Auxiliary frequency	grey	-

\* with identity code characteristic "Control version": 2 and 3



Refer to the functional description for the hierarchy of functions and operating modes.

#### "Pause" function

The pump does not work if:

- the cable is connected and pin 1 and pin 4 are open.

The pump works if:

- the cable is connected and pin 1 and pin 4 are connected.
- no cable is connected.



**"External contact" operating mode**

The pump performs one or more strokes if:

- Pin 2 and pin 4 are connected to each other for at least 20 ms. At the same time, pin 1 and pin 4 must also be connected to each other.

**"Analog" operating mode**

The pump stroke rate can be controlled by a current signal. The current signal is connected between pin 3 and pin 4.

In addition, pin 1 and pin 4 must also be connected.

**"Auxiliary frequency" operating mode**

The pump works at a pre-set stroke rate if:

- Pin 5 and pin 4 are connected to each other. At the same time, pin 1 and pin 4 must also be connected to each other. The auxiliary frequency is factory-preset to the maximum stroke rate.

**9.2.2 "Level Switch" terminal**

There is a connecting option for a 2-stage level switch with pre-warning and limit stop.

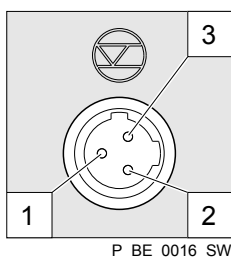

Fig. 11: Pump pin assignments

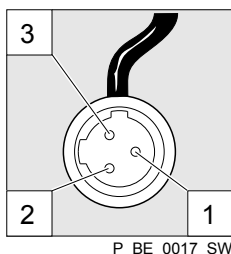

Fig. 12: Cable conductor assignments

Electrical interface

Data	Value	Unit
Voltage with open contacts	5	V
Input resistance	10	kΩ

Control via:

- potential-free connection contact (load: 0.5 mA at 5 V) or
- Semiconductor switch (residual voltage < 0.7 V)

Pin	Function	3-conductor cable
1	Earth / GND	black
2	Minimum pre-warning	blue
3	Minimum limit stop	brown

**9.2.3 "Dosing monitor" terminal**

There is a connecting option for a dosing monitor.

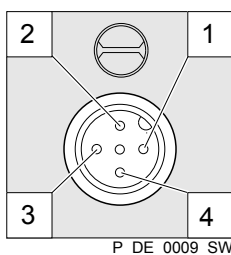

Fig. 13: Pump pin assignments

Electrical interface

Data	Value	Unit
Voltage with open contacts	5	V
Input resistance	10	kΩ

Control via:

- potential-free connection contact (load: 0.5 mA at 5 V) or

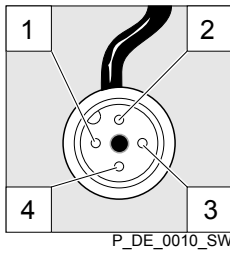

Fig. 14: Cable conductor assignments

Pin	Function	4-conductor cable
1	Power supply (5 V)	brown
2	Coding	white
3	Feedback	blue
4	Earth / GND	black

## 9.2.4 Relay

### 9.2.4.1 "Fault indicating relay" output (identity code 1 + 3 or 4 + 5)

A fault indicating relay can optionally be ordered. It switches in the event of a fault. An identity code pre-warns whether the relay closes or opens in the event of a fault.

If the fault indicating relay is retrofitted, it closes by default in the event of a fault. The relay board is fully functional once plugged in.

The pump is factory-programmed to "Fault indicating relay". Should another switching function be required, the pump can be reprogrammed in the Heidelberg works.

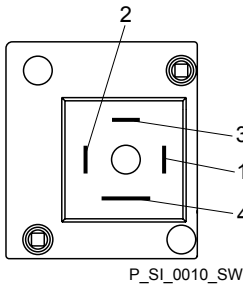

Fig. 15: Pump pin assignments

#### Electrical interface

Data	Value	Unit
Maximum contact load at 250 V and 50/60 Hz:	2	A
Minimum mechanical lifespan:	200 000	Switching operations

#### Identity code 1 + 3 or 4 + 5

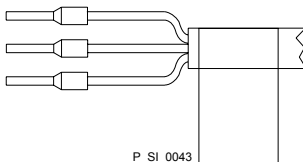

Fig. 16: Cable conductor assignments

To pin	VDE cable	Contact	CSA cable
1	white	NO (normally open)	white
2	green	NC (normally closed)	red
4	brown	C (common)	black

### 9.2.4.2 "Fault indicating and pacing relay" output (identity code 4 + 5)

A fault indicating and a pacing relay can optionally be ordered - refer to ordering information. The pacing output is electrically-isolated by means of an optocoupler with a semiconductor switch. The second switch is a relay, as with the "Fault indicating relay" version.

The fault indicating/pacing relay can be retrofitted.

The pump is factory-programmed to "Fault indicating relay opening" and "Pacing relay closing". Should another switching function be required, the pump can be reprogrammed in the Heidelberg works.

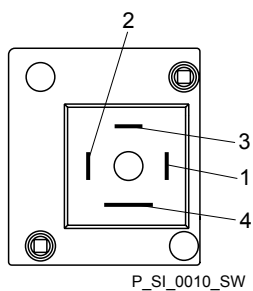

Fig. 17: Pump pin assignments

Electrical interface

for fault indicating relay output:

Data	Value	Unit
Maximum contact load at 24 V and 50/60 Hz:	100	mA
Minimum mechanical lifespan:	20,000,000	Switching operations

for semiconductor switch pacing relay:

Data	Value	Unit
Max. residual voltage when $I_C = 1 \text{ mA}$	0.4	V
Maximum current	100	mA
Maximum voltage	24	VDC
Pacing pulse duration, approx.	100	ms

Identity code 4 + 5

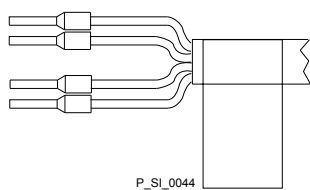

Fig. 18: Cable conductor assignments

To pin	VDE cable	Contact	Relay
1	yellow	NO (normally open)	Fault indicating relay
4	green	C (common)	Fault indicating relay
3	white	NO (normally open)	Pacing relay
2	brown	C (common)	Pacing relay

# 10 Adjustment



For supplementary information see "Control elements and key functions" in the chapter "Overview of equipment and control elements" and "Operating/setting overview" in the appendix.



The pump control returns to the continuous display, as soon as no key has been pressed for one minute.

## 10.1 Basic principles of pump adjustment

= Installation option  
 = flashes

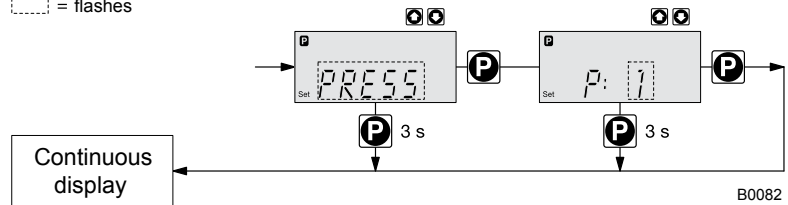

Fig. 19

### Confirming an entry

- ➔ Briefly press the [P] key
  - ⇒ The display simultaneously changes to the next menu option or into a continuous display.

### Quitting a menu point without confirming it

- ➔ Press and hold the [P] key for 3 seconds
  - ⇒ Entry is cancelled and you jump back to a continuous display.

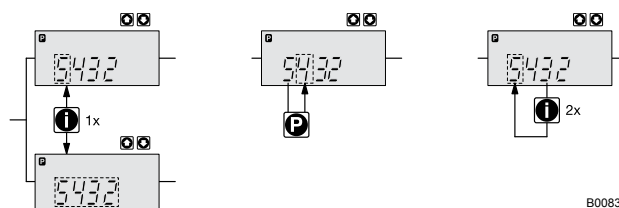

Fig. 20: a) Toggle between changing of individual digits and changing a number; b) Changes the position within the number; c) jump back in the number. More detailed explanations are given in the following text.

### Incremental changing of a value

- ➔ Press the [I] key once.

You can toggle between altering the digits of a value ("change individual digits" = standard) and incremental changing of a value ("change a number").

### Changing adjustable values

- Press the arrow keys *[UP]* or *[DOWN]*.
  - ⇒ The flashing digit or number counts up or down.

### Confirming adjustable values

- Under "change individual digits": confirm each digit by pressing the *[P]* key.
  - ⇒ Upon confirming the last individual digit, the display simultaneously changes to the next menu option or into a continuous display.
- Under "change a number": Press the *[P]* key 1x.
  - ⇒ The display simultaneously changes to the next menu option or into a continuous display.

### Correcting incorrectly set digits

- Press the *[i]* key 2x.
  - ⇒ You jump back to the first digit.

## 10.2 Checking adjustable values

Before you adjust the pump control, you can check the actual settings of the adjustable values:

- Press the *[i]* key ("i" for "Info"), if the LCD screen shows a continuous display (The display does not contain the *[P]* key symbol).
  - ⇒ Each press of the *[i]* key toggles the continuous display output to the screen to another continuous display.

The number of continuous displays depends on the identity code, the selected operating mode and the connected additional devices, see overview "Continuous displays" in the appendix.

## 10.3 Changing to adjustment mode

1. ➤ In a continuous display press the *[P]* key for at least 2 seconds.
  - ⇒ The pump control changes to adjustment mode.
2. ➤ If 'CODE 1' was set, then after pressing the *[P]* key, the code must first be entered.

The following menus can initially be chosen in adjustment mode - see also "Operating/setting overview" in the appendix:

- 'MODE' menu
- 'CODE' menu (option)
- 'SET' menu
- 'CLEAR' window



To match the pump to your process requirements, you must observe the following procedure:

1. ➤ In the 'MODE' menu select the operating mode.
2. ➤ If necessary make the settings for this operating mode in the 'SET' menu.

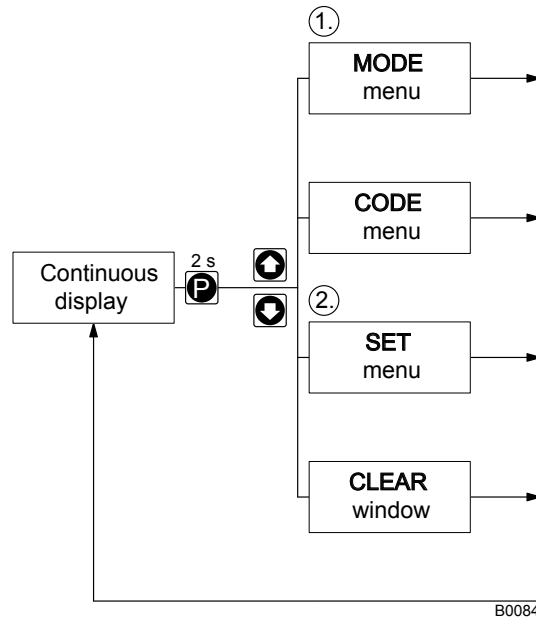

B0084

Fig. 21

Exceptions: Timer and PROFIBUS®.



Note the diagram.

## 10.4 Operating mode selection (MODE menu)

In the 'MODE' menu (dependent on the identity code, some operating modes may not be present):

- 'Manual': for manual operation (identity code control variant: "Manual", available as standard)
- 'Analog': for current control (identity code control variant: "Analog current")
- 'Contact': for contact operation (identity code control variant: "External 1:1" / "External with pulse control")
- 'Batch': for batch operation (identity code control variant: "External with pulse control")

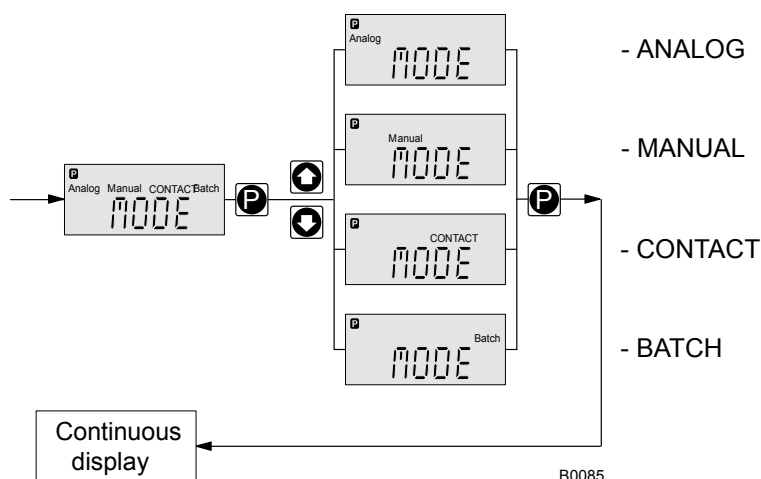

Fig. 22

## 10.5 Operating mode settings (SET menu)



*First in the 'MODE' menu select the operating mode!  
Exceptions: Timer and PROFIBUS®.*

In the 'SET' menu, you can make various settings dependent on the selected operating mode.

Setting menus are available in all operating modes for the following programmable functions:

- Calibrate ( 'CALIB' menu)
- Auxiliary rate ( 'AUX' menu)
- Flow ( 'FLOW' menu; only available if a dosing monitor is connected) - see also the chapter "Programmable function settings (SET menu)".

As to whether or not a further setting menu is available, depends on the selected operating mode.

### 10.5.1 "Manual" operating mode settings

Other than those described in more detail in the chapter "Programmable function settings (SET menu)" there are no other setting menus available in 'Manual' operating mode via the 'SET' menu.

### 10.5.2 "Analog" operating mode settings (ANALG menu)

#### Overview

Alongside those described in more detail in the chapter "Programmable function settings (SET menu)" the 'ANALG' menu is also available in 'Analog' operating mode via the 'SET' menu.

The stroke rate is controlled using an analog current signal via the "External control" terminal

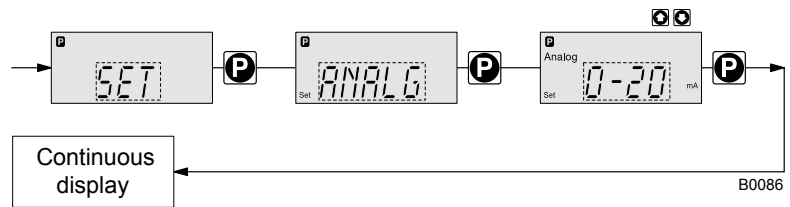

Fig. 23

You can select three types of current signal processing:

- '0 - 20 mA':
  - At 0 mA the pump is stationary.
  - At 20 mA the pump works at the maximum stroke rate.
  - Between these values, the stroke rate is proportional to the current signal.
- '4 - 20 mA':
  - At 4 mA the pump is stationary.
  - At 20 mA the pump works at the maximum stroke rate.
  - Between these values, the stroke rate is proportional to the current signal.
  - For current signals less than 3.8 mA a fault message appears and the pump stops (e.g. if a cable has broken).
- 'Curve': Under the 'Curve' processing type, you can freely program the pump behaviour. There are three options:
  - Line .....
    - Lower sideband ---\\_\_
    - Upper sideband \_\_/---

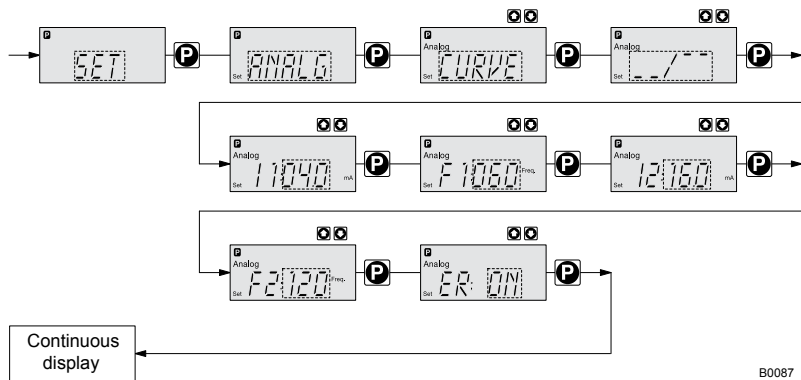

Fig. 24

**Line**

The symbol ..... appears on the LCD screen. You can enter any stroke rate- behaviour of the pump proportional to the current signal. For this purpose, enter any two points P1 (I1, F1) and P2 (I2, F2) (F1 is the stroke rate at which the pump is to operate at current I1); this defines a straight line and thus the behaviour is specified:



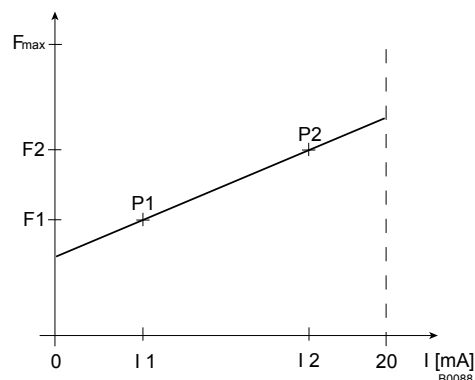

Fig. 25

F1 Stroke rate at which the pump should operate with current I1  
 F2 Stroke rate at which the pump should operate with current I2



Plot a diagram similar to the one above - with values for (I1, F1) and (I2, F2) - so that you can set the pump control as required.

### Upper/lower sideband

Using these processing types, you can control a metering pump using the current signal as shown in the diagrams below.

#### Lower sideband:

The symbol  $\overline{\text{---}}$  appears on the LCD screen. Below I1, the pump works at a rate of F1 - above I2 it stops. Between I1 and I2 the stroke rate varies between F1 and F2 in proportion to the signal current.

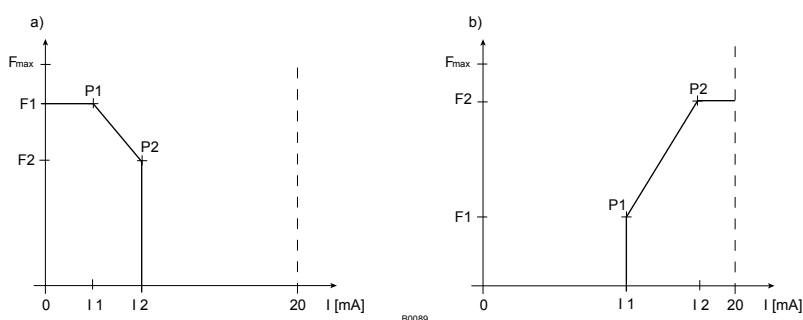

Fig. 26: Lower sideband, e.g. alkali pump

#### Upper sideband:

The symbol  $\text{---}/$  appears on the LCD screen. Below I1, the pump is stationary - above I2 the pump works at rate F2. Between I1 and I2 the stroke rate varies between F1 and F2 in proportion to the signal current.

The smallest processable difference between I1 and I2 is 4 mA

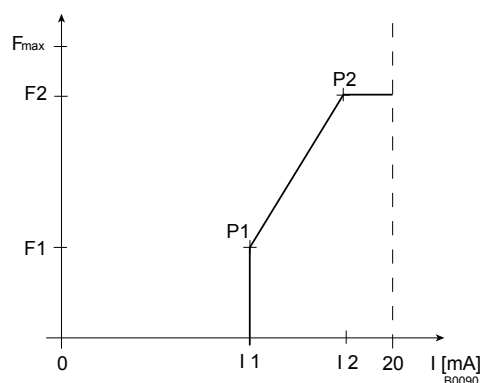

Fig. 27: Upper sideband, e.g. acid pump

## Fault processing

Under menu option 'ER' (Error) you can activate error processing for the 'Curve' processing type. For current signals below 3.8 mA, a fault message appears and the pump stops.

### 10.5.3 "Contact" operating mode settings (CNTCT menu)

Alongside those described in more detail in the chapter "Programmable function settings (SET menu)" the 'CNTCT' menu is also available in 'Contact' operating mode via the 'SET' menu.

'Contact' operating mode allows you to trigger individual strokes or a stroke series. You can trigger the strokes via a pulse sent via the "external control" terminal. The purpose of this operating mode is to convert the incoming pulses with a reduction (bridge) or small step-up into strokes.



#### CAUTION!

If you change into another operating mode, the factor is reset to "1".

With identity code version "Contact - identity code: External with pulse control", you can enter after how many pulses a stroke should occur. "Contact - identity code: External with pulse control" is intended for small metering quantities.

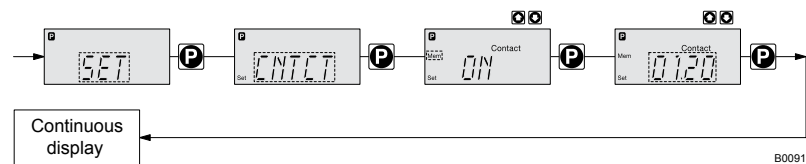

Fig. 28

The number of strokes per pulse depends on the factor which you input. By use of the factor you can multiply incoming pulses by a factor between 1.01 and 99.99 or reduce them by a factor of 0.01 to 0.99:

$$\text{Number of strokes executed} = \text{factor} \times \text{number of incoming pulses}$$

## Example

## Example table

	Factor	Pulse (sequence)	Number of strokes (sequence)
<b>Step-up</b>	1	1	1
	2	1	2
	25	1	25
	99.99	1	99.99
	1.50	1	1.50 (1 / 2)
	1.25	1	1.25 (1 / 1 / 1 / 2)
<b>Reduction</b>	1	1	1
	0.50	2	1
	0.50	10	1
	0.50	100	1
	0.50	4	1
	0.50	2.5 (3 / 2)	(1 / 1)
	0.50	1.33 (2 / 1 / 1)	(1 / 1 / 1)

## Explanation of step-up

Factor	Pulse and strokes
with a factor 1 ...	1 stroke is executed per pulse
with a factor 2 ...	2 strokes are executed per pulse
with a factor 25 ...	25 strokes are executed per pulse

## Explanation of reduction

Factor	Pulse and strokes
with a factor 1 ...	1 stroke is completed after 1 pulse
with a factor 0.5 ...	1 stroke is completed after 2 pulses
with a factor 0.1 ...	1 stroke is completed after 10 pulses
with a factor 0.75 ...	1 stroke is completed after 2 pulses once, then 1 stroke is completed after 1 pulse twice and then (repeating) 1 stroke after 2 pulses, etc...



*If a remainder is obtained when dividing by the factor, then the pump software adds the remainders together. As soon as this sum reaches or exceeds "1", the pump executes an additional stroke. Therefore on average during the metering operation, the resultant number of strokes precisely matches the factor.*

### "Memory" function extension

You can also activate the "Memory" function extension (identifier '*Mem*' appears on the LCD screen; '*Mem*' = memory). When "Memory" is activated, the pump software adds up the remaining strokes, which could not be processed, up to the maximum capacity of the stroke memory of 65,535 strokes. If this maximum capacity is exceeded, the pump goes into fault mode.

You can thus optimally match the pump to the process in question, for example in conjunction with contact water meters.

## 10.5.4 "Batch" operating mode settings (BATCH menu)

Alongside those described in more detail in the chapter "Programmable function settings (SET menu)" the '*BATCH*' menu is also available in '*Batch*' operating mode via the '*SET*' menu.

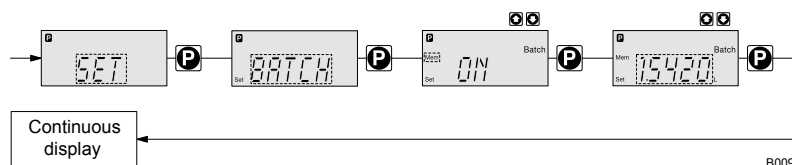

Fig. 29

The operating mode '*Batch*' is a variant of the operating mode '*Contact*' - in the first place see "*Contact*' operating mode settings". Here also, you can select a number of strokes (no fractions, only integers from 1 to 65535), but also a metering quantity (Batch). To change between the input "Number of strokes" and "Metering quantity" press the [*i*] key 1x under the corresponding menu option (see "Operating / adjustment overview" in the appendix).

'*Batch*' operating mode is intended for large metering quantities.

The metering can be triggered either by pressing the [*P*] key or by a pulse received via the "External control" terminal.

The number of received pulses, which could not yet be processed, is stored by the pump control in the stroke memory. The stroke memory is limited to the Batch size if "Memory" is not activated, with "Memory" to 65535 strokes.

You can delete it by changing to another operating mode.

### "Memory" function extension

You can also activate the "Memory" function extension (identifier '*Mem*' appears on the LCD screen; '*Mem*' = memory). When "Memory" is activated, the pump software adds up the remaining strokes, which could not be processed, up to the maximum capacity of the stroke memory of 65,535 strokes. If this maximum capacity is exceeded, the pump goes into fault mode.

You can thus optimally match the pump to the process in question, for example in conjunction with contact water meters.

## 10.6 Programmable function settings (SET menu)

Setting menus are available in the SET menu in all operating modes for the following programmable functions:

- Calibrate ( '*CALIB*' menu)
- Auxiliary rate ( '*AUX*' menu)
- Flow ( '*FLOW*' menu; (only available if a dosing monitor is connected)

## 10.6.1 "Calibrate" function settings (CALIB menu)

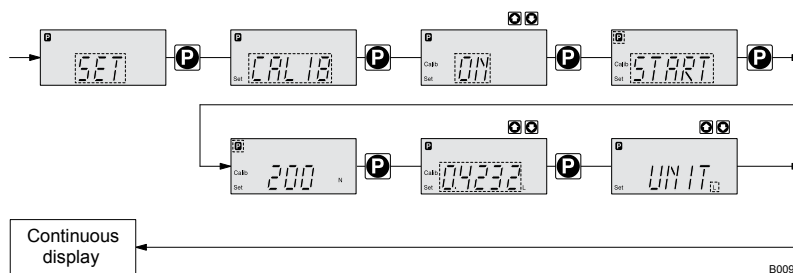

Fig. 30

The pump can also be operated in the calibrated state. In this case, the corresponding continuous displays then indicate the metering volume or the capacity directly. The calibration is maintained when the stroke length is altered by up to  $\pm 10$  scale divisions (for a set stroke length of 40 % this corresponds to a range from 30 % ... 50 %). If the stroke length is changed by more than  $\pm 10$  scale divisions, the yellow warning light illuminates, the continuous display flashes and the flashing identifier 'Calib' appears.



- Do not allow the stroke length to fall below 30% (SEK type: 50%)! Otherwise the calibration becomes very inaccurate.
- The calibration becomes more accurate, the more strokes the pump makes during calibration. Recommendation: at least 200 strokes.

## Calibrate

**CAUTION!****Danger with dangerous feed chemicals**

Provided the following handling instructions are followed, contact with the feed chemical is possible.

- If the feed chemical is dangerous, take appropriate safety precautions when carrying out the following handling instructions.
- Observe the feed chemical safety data sheet.

1. Lead the suction hose into a measuring cylinder containing the feed chemical - the discharge hose must be installed in a permanent manner (operating pressure, ...!).
2. Prime the feed chemical (press both arrow keys simultaneously), should the suction hose be empty.
3. Record the level in the measuring cylinder and the stroke length.
4. Select the 'CALIB' menu and press the [P] key to change to the first menu option.
5. With an arrow key select 'ON' and press the [P] key to change to the next menu option.
6. To start the calibration, press the [P] key. The pump starts to pump and indicates the stroke rate - at certain intervals 'STOP' appears. The pump works with the stroke rate set under 'MANUAL'.
7. After a reasonable number of strokes, stop the pump with the [P] key.
8. Determine the required metering volume (difference initial volume - residual volume).
9. Enter this amount under the next menu option and then press the [P] key to change to the next menu option.

10. ▶ Under menu option 'UNIT' select the units ( 'L' or 'gal') using the arrow keys and press the [P] key.  
 ⇒ The pump is calibrated.

Consequence:

- The corresponding continuous displays indicate the calibrated values.
- Total number of strokes and total litres are set to "0" by calibrate.
- The pump is in the STOP state.

### 10.6.2 "Pressure ratings" function settings (PRESS menu)

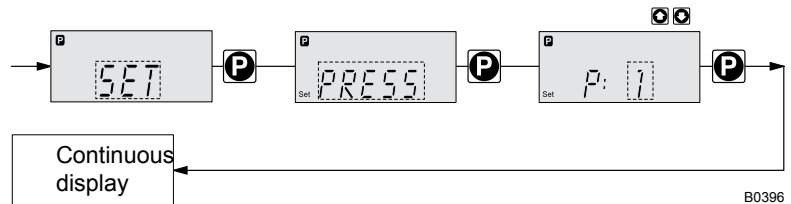

Using the "Pressure ratings" function, you can reduce the rated pressure of the gamma/ L.



**CAUTION!**

Select the pump rated pressure so it is as large as necessary and as small as possible!

In doing so you are increasing the safety of your system (reduced risk that lines will burst if blocked)! Moreover this preserves the diaphragm and saves power.



**CAUTION!**

The rated pressure can be considerably exceeded for stroke lengths less than 100 %. The rated pressure relates to a 100 % stroke length.



**CAUTION!**

Should a different liquid end size be fitted, then the pump must be reprogrammed in the factory!

The following rated pressures can be selected for these liquid end sizes:

**Selectable rated pressure (bar)**

Size of liquid end	Pressure rating 1	Pressure rating 2	Pressure rating 3	Pressure rating 4
1601, 1602, 1605	4	7	10	16
1000, 1005, 1008	4	7	10	-
0708, 0713	4	7	-	-



No adjustment is possible for pump types 0413, 0420, 0220, and 0232.

### 10.6.3 “Auxiliary frequency” function settings (AUX menu)

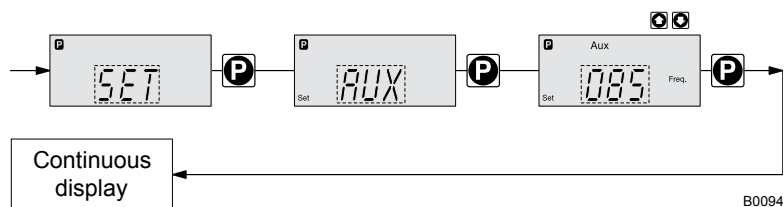

Fig. 31

The programmable function "Auxiliary frequency" facilitates the activating of an auxiliary stroke rate, which can be set in the 'AUX' menu. It can be activated via the "External control" terminal. If the auxiliary frequency is being used, then the identifier 'Aux' appears in the LCD screen.

This auxiliary frequency has priority over the stroke rate, which is specified by the currently selected operating mode.

### 10.6.4 “Flow” function settings (FLOW menu)

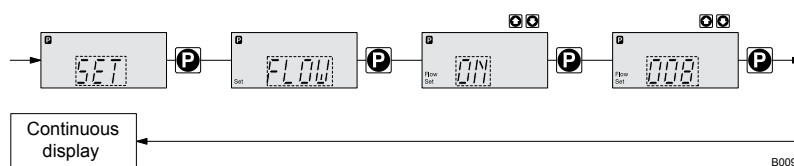

Fig. 32

The 'FLOW' menu only appears if a dosing monitor is connected to the "Dosing monitor" terminal. The metering monitor records the individual metering strokes of the pump at the discharge connector and reports them back to the pump control. If this feedback is sequentially missing for as often as set in the 'FLOW' menu (after a fault or too low metering), the pump is stopped.

### 10.7 Setting the code (CODE menu)

In the 'CODE' menu, you can enter whether you want to block parts of the adjustment options.

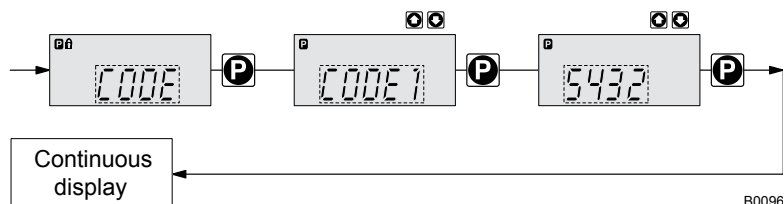

Fig. 33

In the first menu option, you can set either CODE 1 or CODE 2 (both use the same number).

- Select 'CODE 1', to block adjustment mode (① in "Operating / adjustment overview" in the appendix). In the next menu option, enter the number you want to use as the code.
- Select 'CODE 2', to block the option to adjust the directly changeable values in the continuous displays (① in "Operating / adjustment overview" in the appendix). In the next menu option, enter the number you want to use as the code.
- Select 'NONE', to clear a set security lock.

### 10.8 Deleting the total number of strokes or total litres (CLEAR window)

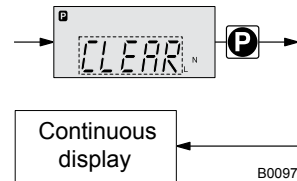

Fig. 34

In the 'CLEAR' window, you can delete the stored total number of strokes and simultaneously the total litres (= reset to "0"). To do this quit the Window by quickly pressing the *[P]* key.

The values have been counted since pump commissioning or since they were last deleted.



# 11 Operation

This chapter describes all the operating options available to you if the pump control is showing a continuous display - then the display does not contain the symbol for the *[P]* key.



- For supplementary information, please read the overviews "Control elements and key functions" and see the "Operating/setting diagram" at the end of the operating instructions.
- Also take note of the overview "Continuous displays". It shows which continuous displays are available in which operating mode and which variables are directly changeable in the relevant continuous display.

## 11.1 Manual operation

### Adjusting the stroke length

The stroke length can be continuously adjusted using the stroke length adjustment knob in the range 0 ... 100 %. The recommended stroke length range, in which the set metering quantity can, from a technical point of view, be accurately reproduced, is 30 ... 100 %

(or for the SEK type: 50 ... 100 %)

The following operating options are available via the keys - see the figure on the next page:

### Stopping/starting the pump

Stop the pump: Press the *[START/STOP]* key.

Start the pump: Press the *[START/STOP]* key again.

### Starting batch

In operating mode 'Batch': Briefly press the *[P]* key.

### Loading factory settings



- Press the [P] key for 15 s, if you want to reload the factory settings prior to calibration!*
- This deletes the current settings.*

### Changing to adjustment mode

In continuous display if you keep the *[P]* key pressed for 2 s, the pump control switches into adjustment mode - see "Adjustment" chapter.

If 'CODE 1' was set, then after pressing the *[P]* key, the code must first be entered.

### Checking adjustable values

Each press of the *[i]* key toggles the continuous display output to the screen to another continuous display. The number of continuous displays depends on the identity code, the selected operating mode and the connected additional devices.

### Changing directly changeable variables

To change a value, see below, directly in the corresponding continuous display, press one of the *[arrow keys]* until the *[Set]* identifier appears.

(The delay period has been programmed in to prevent unintentional changing of values.)

If 'CODE 2' was set, then after pressing an *[arrow key]*, the code must first be entered.

The **directly changeable variables** are in detail:

### Stroke rate

In operating modes *'Manual'*, *'Contact'* and *'Batch'*:  
You can change the stroke rate in the *'Stroke rate'* continuous display.

### Capacity

In operating mode *'Manual'*:  
You can change the capacity in the "Capacity" continuous display.

### Factor

The factor is the number of strokes which are triggered upon an external pulse or pressing of key *[P]* (only in *'Batch'* operating mode).  
In operating mode *'Batch'*:  
You can change the factor from the "Remaining strokes" continuous display. A couple of seconds after your have set the factor, the pump control jumps back to the initial continuous display.

### Displaying the program versions

Press the *[P]* key for 10 s to display the program versions.  
*'V1052' + 'X1010'*



*Under 'LOAD3' release the [P] key immediately!*

### Batch size

In operating mode *'Batch'*:  
You can change the batch size from the "Batch size/Remaining litres" continuous display. A couple of seconds after your have set the factor, the pump control jumps back to the initial continuous display.

### Priming

Simultaneous pressing of the two *[arrow keys]* triggers the "Priming" function.

### Fault acknowledgement

Fault displays are acknowledged by brief pressing of the *[P]* key.

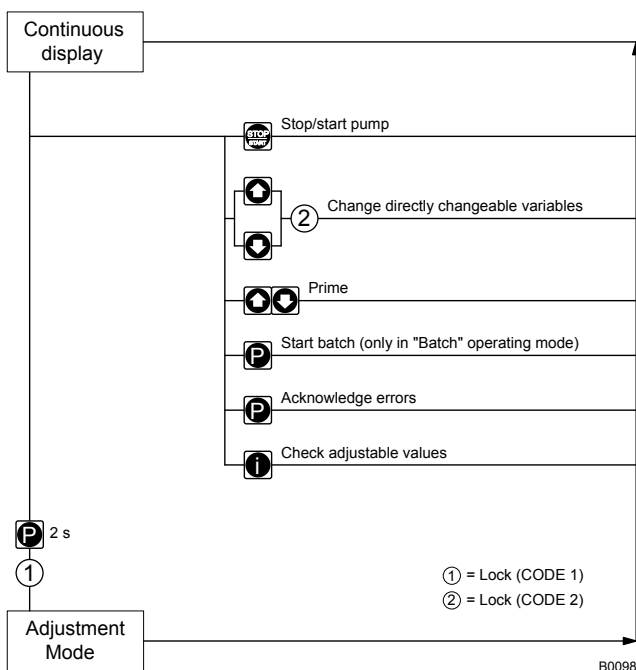

## 11.2 Remote operation

There is an option to control the pump remotely via a signal cable, PRO-FIBUS® or CAN bus - see chapter "Settings - selecting the operating mode (MODE menu)" and chapter "Operation", in the "Supplementary instructions for ProMinent® gamma/ L and ProMinent® Sigma versions with PRO-FIBUS®" as well as your system documentation.

# 12 Maintenance



**WARNING!**

It is mandatory that you read the safety information and specifications in the "Storage, Transport and Unpacking" chapter prior to shipping the pump.



**CAUTION!**

**Warning of feed chemical spraying around**

Feed chemical can spray out of the hydraulic components if they are manipulated or opened due to pressure in the liquid end and adjacent parts of the system.

- Disconnect the pump from the mains power supply and ensure that it cannot be switched on again by unauthorised persons.
- Depressurise the system before commencing any work on hydraulic parts.



**Further data on CD**

All product-specific operating instructions include a CD with order details, exploded diagrams and dimensions sheets, if they are not included in the operating instructions.

**Standard liquid ends:**

Interval	Maintenance work	Personnel
Quarterly*	<ul style="list-style-type: none"> <li>■ Check the metering diaphragm for damage** - refer to "Repair".</li> <li>■ Check that the hydraulic lines are fixed firmly to the liquid end.</li> <li>■ Check that the suction valve and discharge valve are correctly seated.</li> <li>■ Check the tightness of the entire liquid end - particularly around the leakage hole - please refer to !</li> <li>■ Check that the flow is correct: Allow the pump to prime briefly - turn the multifunctional switch briefly to "Test"</li> <li>■ Check that the electrical connections are intact</li> <li>■ Check the integrity of the housing.</li> <li>■ Check that the dosing head screws are tight</li> </ul>	Technical personnel

\* Under normal loading (approx. 30 % of continuous operation)

Under heavy loading (e.g. continuous operation): Shorter intervals.

\*\* For feed chemicals which particularly load the diaphragm, e.g. those containing abrasive additives, check the diaphragm frequently.

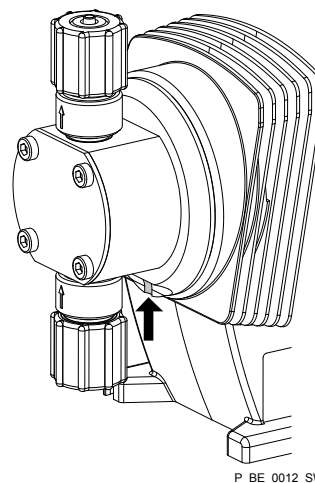

Fig. 35: Leakage hole

**Liquid ends with bleed valve:**

Interval	Maintenance work	Personnel
Quarterly*	In addition: <ul style="list-style-type: none"> <li>■ Check that the bypass line is fixed firmly to the liquid end</li> <li>■ Check that the bleed valve is tight.</li> <li>■ Check the discharge and bypass line for kinks</li> <li>■ Check that the bleed valve is operating correctly.</li> </ul>	Technical personnel

\* Under normal loading (approx. 30 % of continuous operation)  
 Under heavy loading (e.g. continuous operation): Shorter intervals.

**Tightening torque**

Data	Value	Unit
Tightening torque for screws:	4.5 ... 5.0	Nm

# 13 Repairs

## Safety notes



**WARNING!**  
**Danger of an electric shock**

Unauthorised repairs inside the pump can result in an electric shock.

For this reason, repairs inside the pump may only be performed by a ProMinent branch or representative, in particular the following:

- Replacement of damaged mains connection lines
- Replacement of fuses
- Replacement of electronic control



**WARNING!**

It is mandatory that you read the safety information and specifications in the "Storage, Transport and Unpacking" chapter prior to shipping the pump.



**WARNING!**  
**Contact with the feed chemical**

Parts that come into contact with the feed chemical are uncovered and handled during overhaul work.

- Protect yourself against the feed chemical in case it is hazardous. Read the safety data sheet on the feed chemical.



**CAUTION!**  
**Warning of feed chemical spraying around**

Feed chemical can spray out of the hydraulic components if they are manipulated or opened due to pressure in the liquid end and adjacent parts of the system.

- Disconnect the pump from the mains power supply and ensure that it cannot be switched on again by unauthorised persons.
- Depressurise the system before commencing any work on hydraulic parts.

## 13.1 Cleaning valves

Personnel:  General personnel  Technical personnel



**Warning of faulty operation**

*The exploded views on the CD should be referred to when working on the unit.*

Cleaning a discharge valve or a suction valve on types (PP, PV, NP) 1000, 1005, 1605, 1601, 1602



#### **Warning of faulty operation**

- *Discharge and suction valves differ from each other! Only take them apart one after each other, so that you do not confuse the components!*
- *Only use new components which fit your valve - both in terms of shape and chemical resistance!*
- *Recalibrate the pump after replacing a valve!*
- *Using an Allen key or similar, insert it into the smaller hole of the discharge connector and push the valve inserts out of it.*

A suction valve is constructed in almost the same way as a discharge valve.

Please note, however, that:

- the two valve inserts are identical here
- There is an additional spacer between the valve inserts.
- There is a shaped seal in the dosing head instead of an O-ring.
- The flow direction of the suction connector is the opposite of that of the discharge connector.

Cleaning a discharge valve or a suction valve on types (PP, PV, NP) 0708, 1008, 0220, 0420, 0413, 0713, 0232



#### **Warning of faulty operation**

- *Discharge and suction valves differ from each other! Only take them apart one after each other, so that you do not confuse the components!*
- *Only use new components which fit your valve - both in terms of shape and chemical resistance!*
- *Readjust the pump after replacing a valve!*
- *Using an Allen key or similar, insert it into the smaller hole of the discharge connector and push the valve inserts out of it.*

A suction valve is constructed in almost the same way as a discharge valve.

Please note, however, that:

- The shaped seal is laid in the suction connector.
- Only the O-ring, not the shaped seal, is laid in the dosing head.
- The flow direction of the suction connector is the opposite of that of the discharge connector.

## 13.2 Replacing the metering diaphragm



### WARNING!

A few cubic centimetres of feed chemical may have accumulated behind the metering diaphragm in the backplate following a leak - depending on the design!

- Take this feed chemical into consideration when you are planning a repair - especially if it is hazardous!

Personnel: ■ Technical personnel

- If necessary take protective measures.
  - Observe the safety data sheet for the feed chemical.
  - Depressurise the system.
1. Empty the liquid end (turn the liquid end upside down and allow the feed chemical to run out; flush out with a suitable medium; flush the liquid end thoroughly when using hazardous feed chemicals!)
  2. Turn the stroke adjustment dial until the stop at 0 % stroke length if the pump is running (the drive axle is then difficult to turn).
  3. Switch off the pump.
  4. Unscrew the hydraulic connectors on the discharge and suction side.
  5. With types with bleed valve: Firstly remove the bleed valve (star handle), then lift off the cover of the liquid end with a screwdriver.
  6. Remove the screws (1).

For pump types 0220, 0232 and 0420 - refer to the following page (there are 4 holes on the diaphragm edge).

### Liquid end types with the exception of 0220 , 0232 and 0420

1. Loosen the dosing head (2) and the backplate (4) from the pump housing (6) - but only loosen!
2. Hold the pump housing (6) with one hand and clamp the diaphragm (3) with the other hand between the dosing head (2) and the backplate (4).
3. Loosen the diaphragm (3) from the drive axle with a gentle backwards turn of the dosing head (2), diaphragm (3) and backplate (4) in an anticlockwise direction.
4. Unscrew the diaphragm (3) completely from the drive axle.
5. Remove the backplate (4) from the pump housing (6).
6. Check the condition of the safety diaphragm (5) and replace if necessary.
7. Push the safety diaphragm (5) onto the drive axle only until it lies flush with the pump housing (6) and no further!
8. Tentatively screw the new diaphragm (3) onto the drive axle until its stop position.
  - ⇒ The diaphragm (3) is now sitting at the stop of the thread.
9. Should this not work, remove dirt or swarf out of the threads and screw the diaphragm (3) onto the drive axle correctly this time.



*The diaphragm must be screwed exactly onto the drive axle otherwise the pump will subsequently not meter correctly!*



- 10.** ➤ Unscrew the diaphragm (3) again.
- 11.** ➤ Place the backplate (4) onto the pump housing (6).

**CAUTION!****Leakage may become apparent at a later stage.**

- The leakage hole must point downwards when the pump is installed later - please refer to *on page 58!*
- Place the backplate (4) immediately into the correct position on the pump housing (6)! Do not twist the backplate on the pump housing so that the safety diaphragm (5) becomes warped!

- 12.** ➤ Place the diaphragm (3) into the backplate (4).

**CAUTION!****Leakage may become apparent at a later stage.**

- Do not over-tighten the diaphragm (3) in the following step!
- The backplate (4) must remain in its position so that the safety diaphragm does not become warped!

- 13.** ➤ Hold the backplate (4) firmly and screw the diaphragm (3) in a clockwise direction until it is sitting tightly (the twisting resistance of the return spring can be felt).
- 14.** ➤ Set the stroke length to 100 %.
- 15.** ➤ Place the dosing head (2) with the screws (1) onto the diaphragm (3) and the backplate (4) - the suction connector must be pointing downwards in the pumps subsequent fitting position.
- 16.** ➤ Gently tighten the screws (1) and then tighten in a diagonal pattern. See below for tightening torque.
- 17.** ➤ With types with bleed valve: Allow the cover of the liquid end to rest in the dosing head, then press the knob on the bleed valve (star handle) into the dosing head.

**CAUTION!****Leakage possible**

- Check the tightening torque of the screws after 24-hours of operation!
- With PP and PVDF dosing heads, recheck the tightening torque again after three months!

**Tightening torque**

Data	Value	Unit
Tightening torque for screws:	4.5 ... 5.0	Nm

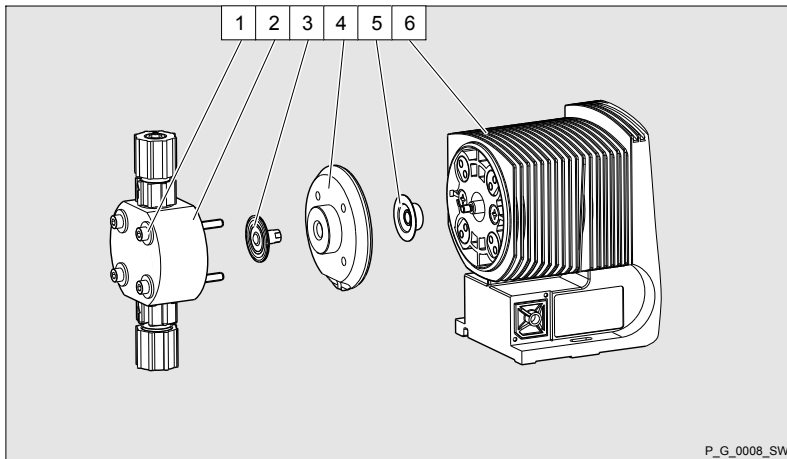

Fig. 36: Partially exploded view of liquid end

Liquid end types 0220 , 0232 and 0420

1. ➤ Remove the dosing head (2) with the screws (1) from the pump.  
Only type 0232: Remove the screws of the backplate (4) under the diaphragm (3). Replace the dosing head (2) and screws - the screws (1) should still extend into the holes in the diaphragm (3), but not into the backplate!
2. ➤ Hold the pump housing (6) with one hand and clamp the diaphragm (3) with the other hand between the dosing head (2) and the backplate (4).
3. ➤ Loosen the diaphragm (3) from the drive axle with a gentle backwards turn of the dosing head (2), diaphragm (3) and backplate (4) in an anticlockwise direction.
4. ➤ Pull the dosing head (2) with the screws (1) out of the diaphragm (3) and completely unscrew this from the drive axle.
5. ➤ Remove the backplate (4) from the pump housing (6).
6. ➤ Check the condition of the safety diaphragm (5) and replace if necessary.
7. ➤ Push the safety diaphragm (5) onto the drive axle only until it lies flush with the pump housing (6) and no further!
8. ➤ Tentatively screw the new diaphragm (3) onto the drive axle until its stop position.  
⇒ The diaphragm (3) is now sitting at the stop of the thread.
9. ➤ Should this not work, remove dirt or swarf out of the threads and screw the diaphragm (3) onto the drive axle correctly this time.



*The diaphragm must be screwed exactly onto the drive axle otherwise the pump will subsequently not meter correctly!*

10. ➤ Unscrew the diaphragm (3) again.
11. ➤ Check whether the diaphragm holes align correctly with the pump housing.
12. ➤ If not, start the pump and adjust the stroke length to 100 %.
13. ➤ With the pump running, slowly turn the diaphragm (3) in the clockwise direction until the 4 diaphragm holes align correctly with the pump housing (6).
14. ➤ Clamp the diaphragm (3) in this position, adjust the stroke length to 0 % and stop the pump.
15. ➤ Unscrew the diaphragm (3) again.

16. Place the backplate (4) onto the pump housing (6).

**CAUTION!****Leakage may become apparent at a later stage.**

- The leakage hole must point downwards when the pump is installed later - please refer to 'Liquid end types 0220 , 0232 and 0420' on page 58!
- Place the backplate (4) immediately into the correct position on the pump housing (6)! Do not twist the backplate on the pump housing so that the safety diaphragm (5) becomes warped!

17. Only type 0232: Screw the backplate (4) on tightly using the screws.

18. Place the diaphragm (3) into the backplate (4).

**CAUTION!****Leakage may become apparent at a later stage.**

- Do not over-tighten the diaphragm (3) in the following step!
- The backplate (4) must remain in its position so that the safety diaphragm does not become warped!

19. Hold the backplate (4) firmly and screw the diaphragm (3) in a clockwise direction until it is sitting tightly (the twisting resistance of the return spring can be felt).

20. Place the dosing head (2) with the screws (1) onto the diaphragm (3) and the backplate (4) - the suction connector must be pointing downwards in the pumps subsequent fitting position.

21. Gently tighten the screws (1) and then tighten in a diagonal pattern. Tightening torque - see above.

22. With types with bleed valve: Allow the cover of the liquid end to rest in the dosing head, then press the bleed valve (star handle) into the dosing head.

**CAUTION!****Leakage possible**

- Check the tightening torque of the screws after 24-hours of operation!
- With PP and PVDF dosing heads, recheck the tightening torque again after three months!

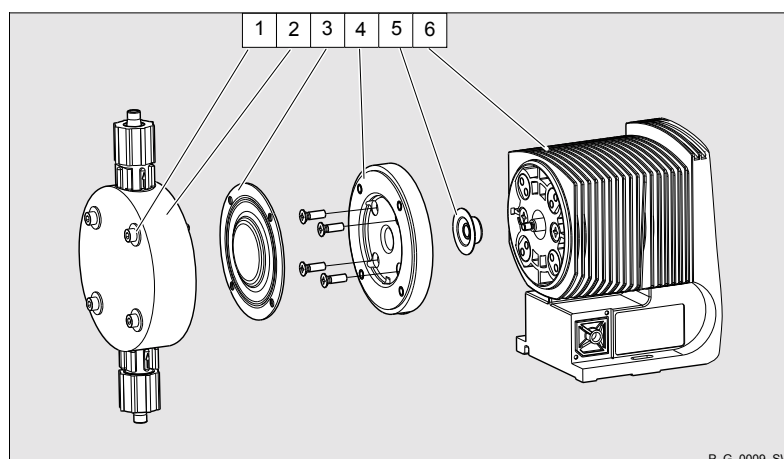

Fig. 37: Partially exploded view of liquid end

# 14 Troubleshooting

## Safety notes



### WARNING!

#### Warning of dangerous or unknown feed chemical

Should a dangerous or unknown feed chemical be used: It may escape from the hydraulic components when working on the pump.

- Take appropriate protective measures before working on the pump (e.g. safety glasses, safety gloves, ...). Observe the safety data sheet for the feed chemical.
- Drain and flush the liquid end before working on the pump.



### CAUTION!

#### Warning of feed chemical spraying around

Feed chemical can spray out of the hydraulic components if they are manipulated or opened due to pressure in the liquid end and adjacent parts of the system.

- Disconnect the pump from the mains power supply and ensure that it cannot be switched on again by unauthorised persons.
- Depressurise the system before commencing any work on hydraulic parts.

## 14.1 Faults without a fault alert

### Faults without a fault alert

Fault description	Cause	Remedy	Personnel
Pump does not prime in spite of full stroke motion and bleeding	Minor crystalline deposits on the ball seat due to the valves drying out	Take suction hose out of the storage tank and thoroughly flush out the liquid end	Technical personnel
	Major crystalline deposits on the ball seat due to the valves drying out	Dismantle the valves and clean them - refer to "Repair"	Technical personnel
Fluid is escaping from the backplate	The screws in the dosing head are too loose	Tighten the screws in the dosing head crosswise - refer to "Repair" for tightening torque.	Instructed personnel
	The metering diaphragm is not tight	Replace the metering diaphragm - refer to "Repair".	Technical personnel
Green LED display (operating display) does not light up	The wrong mains voltage or no mains voltage is connected.	The specified mains voltage can be found on the nameplate.	Electrician

## 14.2 Faults with error message

### 14.2.1 Fault alerts

Fault description	Cause	Remedy
The red LED indicator illuminates, on the display, the identifiers 'Error' and 'MINIM' flash.	The fluid level in the storage tank has reached "liquid level low 2nd stage".	Fill storage tank.

Fault description	Cause	Remedy
The red LED indicator illuminates, on the display, the identifiers 'Error' and 'ANALG' flash.	The pump control is in 'Analog' operating mode, a fault behaviour has been programmed in the 'ANALG' menu and the control current has fallen below 3.8 mA.	Clear the cause of the low control current.  Switch the programming of the fault behaviour to 'OFF' - see chapter "Adjustment - Operating mode settings (SET menu)".
The red LED indicator illuminates, on the display, the identifiers 'Error' and 'CNTCT' flash.	Pump control is in the operating mode 'Contact' or 'Batch' and the function extension "Memory" has been set. Also a very large factor was set, too many contacts have been received or the key [P] has been pressed too often: Consequently a stroke memory overflow has occurred!	Press the [P] key, the memory content is deleted.  Set up the pump again.
The red LED indicator illuminates, on the display, the identifiers 'Error' and 'FLOW' flash.	Dosing monitor not correctly connected.	Connect the dosing monitor correctly.  Press the [P] key.
	The dosing monitor reported more defective strokes than was set in the 'FLOW' menu.	Press the [P] key.  Investigate and clear the cause.
The red LED indicator illuminates, on the display, the identifiers 'Error' and 'TEMPERATURE' flash.	The temperature inside the pump housing is too high due to too high outside temperature.	Ensure lower outside temperatures.  Allow the pump to cool.  Press the [P] key (reset function).
	The temperature inside the pump housing is too high due to too high pump power consumption.	Check the installation, change if necessary.  Allow the pump to cool.  Press the [P] key (reset function).
The red LED indicator illuminates, on the display, the identifiers 'Error' and 'DIAPH' flash.	Metering diaphragm is ruptured.	Replace metering diaphragm according to chapter "Repairs".
The red LED indicator illuminates, on the display, the identifiers 'Error' and 'SYSTEM' flash.	Fault on the control.	Disconnect the pump from the mains/power supply then reconnect.  If the error message continues to appear, send the pump to ProMinent.
The red LED indicator illuminates, on the display, the identifiers 'Error' and 'MEM' flash.	Stroke memory overflow has occurred.	Eliminate cause.  Press [P] key - bear in mind the consequences for your process.

## 14.2.2 Warning Alerts

Fault description	Cause	Remedy
Green LED indicator illuminates.	The liquid level in the storage tank has reached "liquid level low 1st stage".	Fill storage tank.
Green LED indicator illuminates and the identifier 'Calib' flashes.	The pump is calibrated and the stroke length varies by more than $\pm 10$ scale divisions from the value at the time of the calibration.	Reset the stroke length or recalibrate the pump at the desired stroke length.

### 14.3 All Other Faults

Please contact the responsible ProMinent branch or representative.

## 15 Decommissioning

### Decommissioning



#### WARNING!

##### Danger from chemical residues

There is normally chemical residue in the liquid end and on the housing after operation. This chemical residue could be hazardous to people.

- It is mandatory that the safety information relating to the "Storage, transport and unpacking" chapter is read before shipping or transporting the unit.
- Thoroughly clean the liquid end and the housing of chemicals and dirt. Adhere to the safety data sheet for the feed chemical.



#### WARNING!

##### Warning of dangerous or unknown feed chemical

Should a dangerous or unknown feed chemical be used: It may escape from the hydraulic components when working on the pump.

- Take appropriate protective measures before working on the pump (e.g. safety glasses, safety gloves, ...). Observe the safety data sheet for the feed chemical.
- Drain and flush the liquid end before working on the pump.



#### CAUTION!

##### Warning of feed chemical spraying around

Feed chemical can spray out of the hydraulic components if they are manipulated or opened due to pressure in the liquid end and adjacent parts of the system.

- Disconnect the pump from the mains power supply and ensure that it cannot be switched on again by unauthorised persons.
- Depressurise the system before commencing any work on hydraulic parts.



#### *Danger of damage to the device*

*Take into account the information in the "Storage, Transport and Unpacking" chapter if the system is decommissioned for a temporary period.*

Personnel:  Technical personnel

1. Disconnect the pump from the mains power supply.
2. Empty the liquid end by turning the pump upside down and allowing the feed chemical to run out.
3. Flush the liquid end with a suitable medium; flush the dosing head thoroughly when using hazardous feed chemicals!

### Disposal



#### CAUTION!

##### Warning of feed chemical spraying around

Feed chemical can spray out of the hydraulic components if they are manipulated or opened due to pressure in the liquid end and adjacent parts of the system.

- Disconnect the pump from the mains power supply and ensure that it cannot be switched on again by unauthorised persons.
- Depressurise the system before commencing any work on hydraulic parts.

Personnel:                   ■ Technical personnel



#### CAUTION!

##### Environmental hazard due to electronic waste

There are electronic components in the pump, which can have a toxic effect on the environment.

- Separate the electronic components from the remaining parts.
- Note the pertinent regulations currently applicable in your country!



## 16 Technical data

### 16.1 Performance data

gamma/ L operating at 180 strokes/minute  
and 100 % stroke length

Type	Minimum pump capacity at maximum back pressure			Minimum pump capacity at medium back pressure			Con- nector size  outside Ø x inside Ø	Suction lift*	Priming lift**	Max- imum priming pressure on suc- tion side
	bar	l/h	ml/ stroke	bar	l/h	ml/ stroke				
<b>gamma/ L</b>										
1000	10	0.74	0.069	5.0	0.82	0.076	6x4	6.0	1.8	8
1601	16	1.1	0.10	8.0	1.40	0.13	6x4	6.0	2.0	8
1602	16	2.1	0.190	8.0	2.5	0.24	6x4	6.0	2.5	5.5
1005	10	4.4	0.41	5.0	5.0	0.46	8x5****	5.0	3.0	3
0708	7	7.1	0.66	3.5	8.4	0.78	8 x 5	4.0	2.0	2
0413	4	12.3	1.14	2.0	14.2	1.31	8 x 5	3.0	2.5	1.5
0220	2	19.0	1.76	1.0	20.9	1.94	12x9	2.0	2.0	1
1605	16	4.1	0.38	8.0	4.9	0.45	8x5****	4.0	3.0	3
1008	10	6.8	0.63	5.0	8.3	0.76	8 x 5	3.0	3.0	2
0713	7	11.0	1.02	3.5	13.1	1.21	8 x 5	3.0	3.0	1.5
0420	4	17.1	1.58	2.0	19.1	1.77	12x9	3.0	3.0	1
0232	2	32.0	2.96	1.0	36.2	3.35	12x9	2.0	2.0	0.8
<b>gamma/ L Metering pumps with self-bleeding dosing head SEK***</b>										
1601	16	0.59	0.055	8.0	0.78	0.072	6x4	1.8	1.8	0.5
1602	16	1.40	0.13	8.0	1.74	0.16	6x4	2.1	2.1	0.5
1005	10	3.6	0.33	5.0	4.0	0.37	8 x 5	2.7	2.7	0.5
0708	7	6.60	0.61	3.5	7.50	0.69	8 x 5	2.0	2.0	0.5
0413	4	10.8	1.0	2.0	12.6	1.17	8 x 5	2.5	2.5	0.5
0220	2	16.2	1.5	1.0	18.0	1.67	12x9	2.0	2.0	0.5
1605	16	3.3	0.31	8.0	3.8	0.35	8 x 5	3.0	3.0	0.5
1008	10	6.3	0.58	5.0	7.5	0.69	8 x 5	3.0	3.0	0.5
0713	7	10.5	0.97	3.5	12.3	1.14	8 x 5	2.5	2.5	0.5
0420	4	15.6	1.44	2.0	17.4	1.61	12x9	2.5	2.5	0.5

- \* - Suction lift with a filled suction line and filled liquid end. With self-bleeding dosing head with air in the suction line.
- \*\* - Priming lift with clean and moist valves. Priming lift at 100 % stroke length and free outlet or opened bleed valve.
- \*\*\* - The given performance data constitutes guaranteed minimum values, calculated using medium water at room temperature. The bypass connection with a self-bleeding dosing head is 6x4 mm.
- \*\*\*\* - The connector width is 6 mm on SST material versions.

## 16.2 Accuracy

### 16.2.1 Standard Liquid End

Data	Value	Unit
Capacity range of the series	-5 ... +10	% *
Reproducibility	±2	% **

\* - at max. stroke length and max. operating pressure for all material versions

\*\* - at constant conditions and min. 30 % stroke length

### 16.2.2 Self-Bleeding Liquid End

As the self-bleeding liquid end is used with outgassing media and when operating with air bubbles, no dosing accuracy or reproducibility can be provided.

The recommended minimum stroke length with self-bleeding dosing pumps is 50 %.

## 16.3 Viscosity

The liquid ends are suitable for the following viscosity ranges:

Version	Range	Unit
Standard	0 ... 200	mPa
With valve springs	200 ... 500	mPa
Self-bleeding (SEK)	0 ... 50	mPa

\* Only when the installation is correctly adjusted

## 16.4 Material specifications

### Standard liquid ends

Version	Dosing head	Suction/discharge connector	Seals	Valve balls
PPE	Polypropylene	Polypropylene	EPDM	Ceramic
PPB	Polypropylene	Polypropylene	FPM	Ceramic
NPE	Clear acrylic	PVC	EPDM	Ceramic
NPB	Clear acrylic	PVC	FPM	Ceramic
PVT	PVDF	PVDF	PTFE	Ceramic
TTT	PTFE with carbon	PTFE with carbon	PTFE	Ceramic
SST	Stainless steel 1.4571	Stainless steel 1.4571	PTFE	Ceramic

Only the self-bleeding design in material version PPE, PPB, NPE and NPB: valve spring made of Hastelloy C, valve insert made of PVDF.

Metering diaphragms with a PTFE coating.

FPM = fluorine rubber.

### Pump

Housing parts: polyphenylene ether (PPE with fibreglass)

## 16.5 Electrical data

Version: 100 - 230 V  $\pm$ 10 %, 50/60 Hz, gamma/ L GALa

Parameter	M70	M85
Nominal power, approx.	17 W	23 W
Current I <sub>eff</sub>	0.5 ... 0.2 A	0.8 ... 0.3 A
Peak current	3.6... 1.4 A	6.0 ... 2.8 A
Switch on peak current (within approx. 1 ms)	15 A	15 A
Fuse*	0.8 AT	0.8 AT

\* Fuses must have VDE, UL and CSA certification. E.G. type 19195 manufactured by Wickmann in compliance with IEC Publ. 127 - 2/3.

## 16.6 Temperatures

### Pump, compl.

Data	Value	Unit
Storage and transport temperature	-10 ... +50	°C
Ambient temperature in operation (drive and control):	-10 ... +45	°C

### Liquid end

Material version	Long term	Temporary *
PP	50 °C	100 °C
NP	45 °C	60 °C

Material version	Long term	Temporary *
PV	45 °C	120 °C
TT	50 °C	120 °C
SS	50 °C	120 °C

\* Temp. max., for 15 min at max. 2 bar, dependent on the ambient and feed chemical temperatures

## 16.7 Climate

Data	Value	Unit
Maximum air humidity *:	95	% rel. humidity

\* non-condensing

Exposure in a humid and alternating climate:  
FW 24 according to DIN 50016

## 16.8 Protection class and Safety Requirements

### Degree of protection

Protection against contact and humidity:  
IP 65 in accordance with IEC 529, EN 60529, DIN VDE 0470 Part 1

### Safety requirements

Degree of protection:  
1 - mains power connection with protective earth conductor

## 16.9 Compatibility

Some hydraulic parts of the gamma/ L are identical to those of the Beta® product range.

There is substantial compatibility with the following components and accessories with pumps in the product ranges Beta®, CONCEPT, gamma and gamma-Classic:

- Signal cable gamma/Vario 2-, 4- and 5-wire for the "External" function
- Level switch 2-stage (gamma / Vario / Beta®)
- Metering line cross-sections
- Standard gamma connector kit
- gamma wall bracket
- Chemical feed containers and fastening plates
- Overall height (distance between the suction and discharge connector)
- Distance between the connectors and the pump fixing holes
- Identical use of accessories, such as back pressure valves, multifunctional valves, dosing monitor and flushing equipment

## 16.10 Sound pressure level

Sound pressure level

Sound pressure level LpA < 70 dB in accordance with EN ISO 20361:2010-10

at maximum stroke length, maximum stroke rate, maximum back pressure (water)

## 16.11 Shipping weight

Shipping weight of gamma/ L types - in kg

Material	Types			
	1000, 1601, 1602	1005, 0708, 0413, 0220	1605, 1008, 0713	0420, 0232
PP, NP, PV, TT	2.9	3.1	4.5	5.5
SS	3.6	4.5	5.9	8.6

# 17 EC Declaration of Conformity

For mains voltage pumps:

<b>- Original - EC Declaration of Conformity for Machinery</b>	
We,	<b>ProMinent Dosiertechnik GmbH</b>
	<b>Im Schuhmachergewann 5 - 11 DE - 69123 Heidelberg</b>
that the following designated product complies with the pertinent fundamental safety and health requirements of the EC Directive in terms of its design and construction and in terms of the version marketed by us.	
This declaration loses its validity in the event of a modification to the product not agreed with us.	
Description of the product:	<b><i>Metering pump, Gamma L product range</i></b>
Product type:	<b><i>GALa _ _ _ _ _ U _ _ _ _ _</i></b>
Serial no.:	<b><i>Please refer to nameplate on the device</i></b>
Pertinent	<b><i>EC - Machinery Directive (2006/42/EC)</i></b>
EC Directives:	<b><i>EC EMC Directive (2004/108/EC) The safety objectives of the Low Voltage Directive 2006/95/EC are in accordance with Appendix I, No. 1.5.1 of the Machinery Directive 2006/42/EC</i></b>
Applied harmonised standards	<b><i>EN ISO 12100, EN 809,</i></b>
in particular:	<b><i>EN 60335-1, EN 60335-2-41, EN 50106, EN 61000-3-3, EN 61000-4-2/3/4/5/6/11, EN 61000-6-1/2/3/4</i></b>
Technical documents have been compiled by:	<b><i>Norbert Berger</i></b>
Documentation specialist:	<b><i>Im Schuhmachergewann 5-11 DE-69123 Heidelberg</i></b>
Date / Manufacturer's signature:	<b><i>5.10.2011</i></b> 
Details of the signatory:	<b><i>Joachim Schall, Head of Development</i></b>

For low voltage pumps:

**- Original -  
EC Declaration of Conformity for Machinery**

We, **ProMinent Dosiertechnik GmbH Im  
Schuhmachergewann 5 - 11  
DE - 69123 Heidelberg**

hereby declare that, the product specified in the following complies with the relevant basic health and safety rules of the EC Directive, on the basis of its functional concept and design and in the version marketed by us.  
This declaration loses its validity in the event of a modification to the product not agreed with us.

Description of the product: ***Metering pump, Gamma L product range***

Product type: **GALa \_\_\_\_\_ M \_\_\_\_\_  
GALa \_\_\_\_\_ N \_\_\_\_\_  
GALa \_\_\_\_\_ P \_\_\_\_\_**

Serial no.: ***Please refer to nameplate on the device***

Relevant EC Directives: ***EC Machinery Directive (2006/42/EC) EC -  
EMC directive (2004/108/EC)***

Harmonised standards applied, in particular: ***EN ISO 12100, EN 809,  
EN 60335-1, EN 60335-2-41, EN 50106,  
EN 61000-3-3, EN 61000-4-2/3/4/5/6/11,  
EN 61000-6-1/2/3/4***

Technical documents have been compiled by documentation specialists: ***Norbert Berger  
Im Schuhmachergewann 5-11  
DE-69123 Heidelberg***

Date / manufacturer's signature: ***5.10.2011*** 

Details of the signatory: ***Joachim Schall, Head of Development***

# 18 Operating / adjustment overview

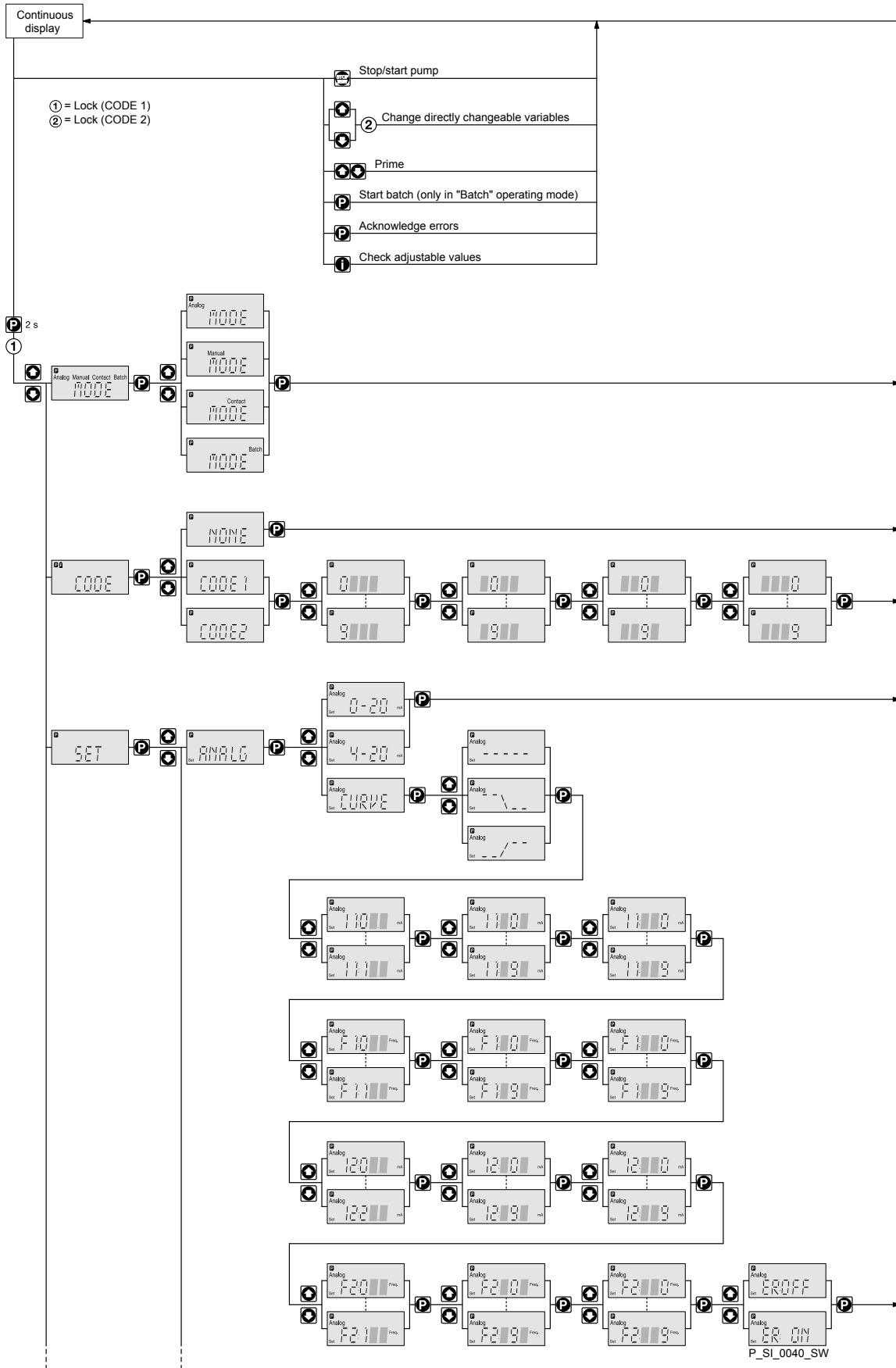



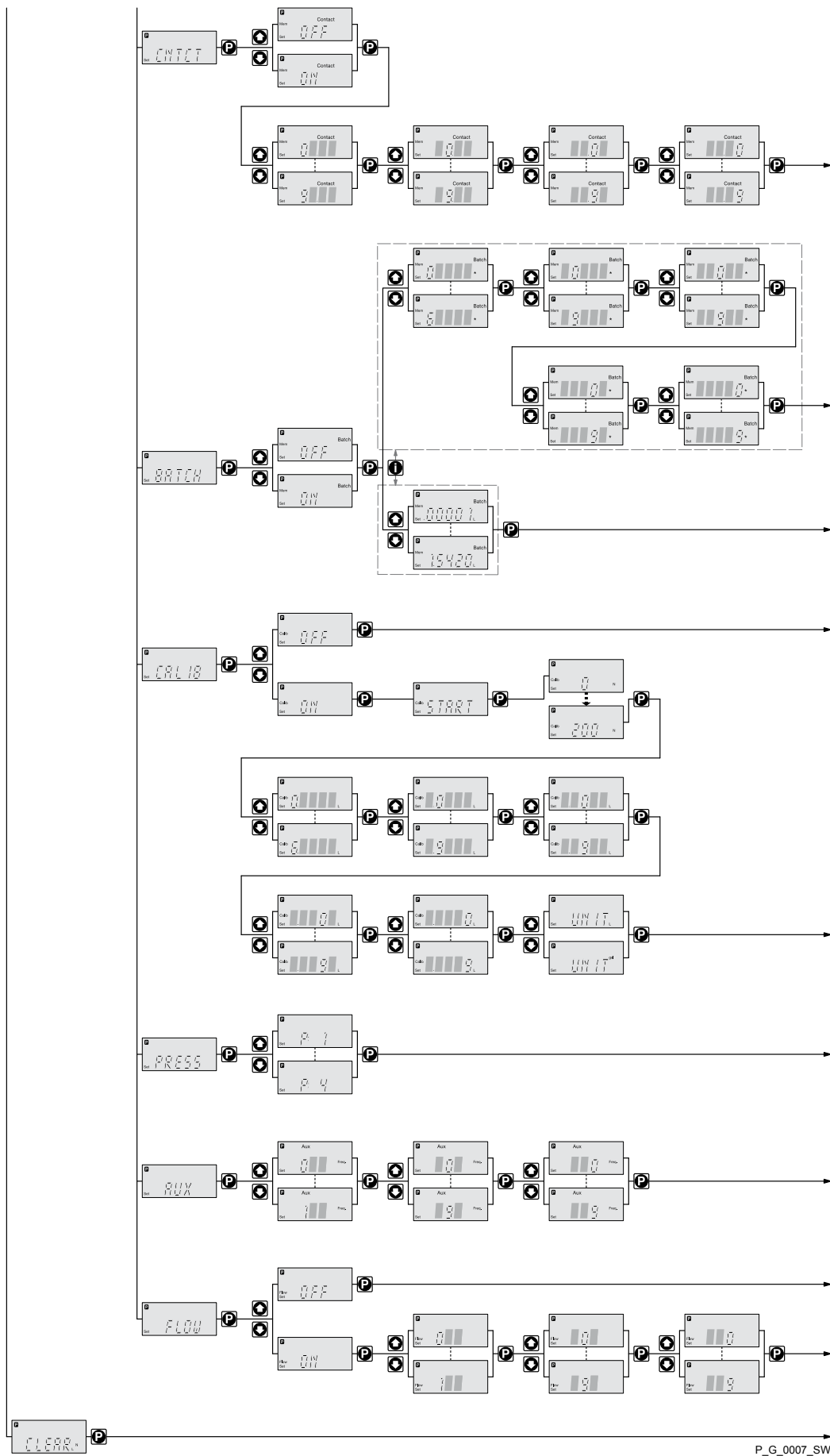

P\_G\_0007\_SW

# 19 Continuous displays

## Continuous displays

Continuous display	Operating mode "Analog" 0...20 mA	"Manual" operating mode	Operating mode "Contact" with memory and transfer factor 5	"Batch" operating mode with memory
Stroke rate				
Capacity				
Total number of strokes				
Total litres (metering quantity)				
"External" display				
Signal current				
Remaining strokes				
Batch size / Remaining litres				
Factor				
Stroke length				
= values which can be changed directly using the UP or DOWN arrow keys			Identifier "Mem" only in the event that function extension "Memory" is activated	

## 20 Index

"	
"Analog" operating mode settings.....	39
"Batch" operating mode settings.....	44
"Contact" operating mode settings.....	42
"External control" terminal.....	32
"Manual" operating mode settings.....	39
<b>1, 2, 3 ...</b>	
4 - 20 mA.....	39
<b>A</b>	
Accuracy.....	66
Adjustment.....	36
Adjustment mode.....	37
Analog.....	20, 33, 39
Analog output.....	32
Anti-kink device.....	29
Assembly.....	23
Auxiliary frequency.....	21, 32, 33, 47
Auxiliary rate.....	22
AUX menu.....	47
<b>B</b>	
Basic principles of pump adjustment.....	36
Batch.....	21, 44
Bleeding.....	27, 28
Bleed valve.....	29
BUS.....	21
<b>C</b>	
CALIB menu.....	45
Calibrate.....	45
Calibration.....	21
Changing a number.....	36
Changing individual numbers.....	36
Changing to adjustment mode.....	37
check.....	37
Checking adjustable values.....	37
Cleaning valves.....	54
CLEAR window.....	48
Code setting.....	47
Compatibility.....	68
Confirming an entry.....	36
Connector size.....	65
CONTACT.....	20, 42
Contact relay.....	31
Control elements.....	16
Correct.....	37
Correct and proper use.....	9
Curve.....	39
<b>D</b>	
Decommissioning.....	63
Degree of protection.....	68
delete.....	44, 48
Deleting the total number of strokes or total litres.....	48
Discharge valve.....	29
Disposal.....	64
Dosing monitor.....	33, 47
<b>E</b>	
Electrical data.....	67
Emergency.....	12
Emptying the liquid end.....	63
Explanation of the safety information .....	9
External contact.....	22, 32, 33
External frequency changeover.....	22
<b>F</b>	
Factor.....	42
Fault.....	22
Fault indicating relay.....	22, 34
Fault indicator.....	17, 22
Fault processing.....	42
Fault statuses.....	22
Flow.....	21
FLOW menu.....	47
Function.....	45, 46, 47
Function display.....	22
Functions.....	20, 22, 44
<b>H</b>	
Hierarchy of operating modes.....	22
<b>I</b>	
Identity code.....	6
Incorrectly set digits.....	37
Incremental changing of a value.....	36
Inductive consumers.....	31
Information in the event of an emergency.....	12
Installation, electrical.....	30
Installation, hydraulic.....	24
Install hose lines.....	25
IP.....	68
<b>K</b>	
Keys.....	17
<b>L</b>	
LCD screen.....	17
Leakage hole.....	52
Level switch.....	21, 33, 34
Line.....	40
Lock.....	47
Lower sideband .....	40, 41
<b>M</b>	
Mains Cable.....	31
Maintenance.....	52
Manual.....	20, 22, 39
mA output.....	32
Material specifications.....	67

Memory.....	44	Reproducibility.....	66
Metering pumps with bleed valve.....	27	Return line.....	25, 27, 28
Metering pumps without self-bleeding.....	25	<b>S</b>	
Metering pumps with self-bleeding.....	28	Safety chapter.....	9
Minimum Stroke Length.....	66	Safety declaration form.....	14
MODE menu.....	20, 38	Safety requirements.....	68
<b>O</b>		Scope of supply.....	15
Operating indicator.....	17, 22	SEK.....	28
Operating mode.....	39, 42, 44	SEK types.....	20
Operating modes.....	20, 22	Self-Bleeding.....	20
Operating mode selection.....	38	Semiconductor switch.....	34
Operating mode settings.....	39	SET menu.....	39, 44
Options.....	20	Shipping weight.....	69
Output relay.....	22	Sleeve.....	29
Overview of equipment.....	16	Sockets.....	17
<b>P</b>		Sound pressure level.....	13, 69
Pacing relay.....	22, 34	Step-up.....	43
Parallel connection.....	31	Stop.....	21, 22
Pause.....	21, 22, 32	Storage.....	14
Performance data.....	65	Stroke length adjustment knob.....	17
Power consumption.....	67	Supply Voltage.....	31
PRESS menu.....	46	<b>T</b>	
Pressure ratings.....	46	Technical data.....	65
Priming.....	21, 22	Total litres.....	48
Priming pressure.....	28	Transport.....	14
Programmable function settings.....	44	<b>U</b>	
Protect.....	47	Unpacking.....	14
Protection against contact and humidity.....	68	Upper sideband.....	40, 41
Protection class.....	68	<b>V</b>	
<b>Q</b>		Varistor.....	31
Qualification of personnel.....	12	Viscosity.....	66
Quitting a menu point without confirming it.....	36	<b>W</b>	
<b>R</b>		Warning alert.....	34
Radioactive.....	14	Warning indicator.....	17, 22
RC member.....	31	Warning sign.....	9
Reduction.....	43	<b>"</b>	
Relay.....	34	“Auxiliary rate” function settings.....	47
Repairs.....	54	“Calibrate” function settings.....	45
Replacing the Diaphragm.....	56	“Flow” function settings.....	47
Replacing the metering diaphragm.....	56	“Pressure ratings” function settings.....	46

"

" \_

**ProMinent**[www.promhimtech.ru](http://www.promhimtech.ru) / [zakaz@promhimtech.ru](mailto:zakaz@promhimtech.ru)