

Operating instructions

Precision Piston Metering Pump

mikro delta[®] MDLa

with controlled optoDrive[®] solenoid drive



**Please carefully read these operating instructions before use! · Do not discard!
The operator shall be liable for any damage caused by installation or operating errors!
Technical changes reserved.**

Supplementary information



Fig. 1: Please read!

Read the following supplementary information in its entirety! Should you already know this information, you have an even greater need of the Operating Instructions.

The following are highlighted separately in the document:

■ Enumerated lists

➤ Instructions

⇒ Results of the instructions

Information



This provides important information relating to the correct operation of the system or is intended to make your work easier.

Safety information

Safety information is identified by pictograms - see Safety Chapter.

User information

Please read these operating instructions carefully before use! Do not discard!

State the identity code and serial number

Please state identity code and serial number, which you can find on the nameplate when you contact us or order spare parts. This enables the device type and material versions to be clearly identified.

General non-discriminatory approach

In order to make it easier to read, this document uses the male form in grammatical structures but with an implied neutral sense. It is aimed equally at both men and women. We kindly ask female readers for their understanding in this simplification of the text.

Table of contents

1	Identity code	5
2	About this pump	7
3	Safety chapter	8
4	Storage, transport and unpacking	13
5	Device overview and control elements	15
	5.1 Device overview.....	15
	5.2 Control elements.....	16
	5.2.1 Key functions.....	16
	5.2.2 Stroke length adjustment knob.....	17
	5.2.3 Identifiers.....	17
6	Functional description	20
	6.1 Liquid end.....	20
	6.2 Drive unit.....	20
	6.3 Capacity.....	20
	6.4 Operating modes.....	21
	6.5 Functions.....	21
	6.6 Relay (options).....	22
	6.7 Functional and fault Indicator.....	22
	6.8 LCD display.....	22
	6.9 LED indicators.....	23
	6.10 Hierarchy of operating modes, functions and fault statuses.....	23
7	Assembly	24
8	Hydraulic installation	25
9	Electrical installation	28
	9.1 Supply voltage connector.....	29
	9.2 Description of the jacks.....	30
	9.2.1 "External control" terminal.....	30
	9.2.2 "Level Switch" terminal.....	31
	9.2.3 "Dosing monitor" terminal.....	31
	9.3 Relay.....	32
	9.3.1 "Fault indicating relay" output (identity code 1 + 3 or 4 + 5).....	32
	9.3.2 Output pacer relay (identity code 4 + 5).....	33
10	Set-up	34
	10.1 Basic principles of control adjustment.....	34
	10.2 Checking adjustable values.....	34
	10.3 Changing to adjustment mode.....	35
	10.4 Selecting the operating mode (Menu "Operation")... ..	36
	10.5 Operating mode settings (menu "Settings").....	36
	10.5.1 "Manual" operating mode settings.....	37
	10.5.2 Settings for the "Batch" operating mode (BATCH menu).....	38
	10.5.3 "Contact" operating mode settings.....	39
	10.5.4 "Analog" operating mode settings.....	41
	10.6 Programmable function settings ("Settings" menu).	44
	10.6.1 Settings for the "Auxiliary frequency" function (AUX menu).....	44
	10.6.2 Settings for the "Flow" function (FLOW menu).....	44

10.6.3	Settings for the “Calibrate” function (CALIBRATE menu).....	45
10.6.4	Settings for the “Metering” function (DOSING menu).....	46
10.6.5	Settings for the “Relay” function (RELAY menu)...	48
10.6.6	Settings for the “Analog output” function (ANALOG OUTPUT menu).....	50
10.6.7	Settings in the "System" menu" (SYSTEM menu).	51
10.7	Set code (SECURITY menu).....	52
10.8	Delete total number of strokes or total litres (CLEAR menu).....	53
10.9	Set language (LANGUAGE menu).....	53
11	Operation	54
11.1	Manual.....	55
11.2	Remote operation.....	57
12	Maintenance	58
13	Overhaul	60
13.1	Cleaning valves.....	60
13.2	Replacing liquid end parts.....	63
14	Troubleshooting	67
14.1	Faults without a fault alert.....	67
14.2	Fault alerts.....	68
14.3	Fault alerts / warning alerts.....	68
14.4	Warning Alerts.....	69
14.5	All Other Faults.....	69
15	Decommissioning	70
16	Technical data	72
16.1	Performance data.....	72
16.2	Viscosity.....	72
16.3	Material data.....	73
16.4	Electrical data.....	73
16.5	Temperatures.....	74
16.6	Climate.....	74
16.7	Protection class and Safety Requirements.....	74
16.8	Weight.....	75
16.9	Sound pressure level.....	75
17	Dimensions sheets	76
18	Diagrams for setting the metering capacity	77
19	Exploded view drawings	79
20	Ordering Information	81
21	EC Declaration of Conformity	85
22	Decontamination declaration	86
23	Operating / adjustment overview	87
24	Continuous displays	89
25	Index	91

1 Identity code

Product range delta [®] , version a			
MDL a	Type	Performance	
		bar	ml/h
	100150	10	150 (only TT)
	600150	60	150 (only SS)
	10 600	10	600 (only TT)
	40 600	40	600 (only SS)
	101500	10	1500 (only TT)
	201500	20	1500 (only SS)
		Material dosing head	
	SS	Stainless steel	
	TT	PTFE with 25 % carbon	
		Seal material	
	T	PTFE seals, pure white	
	G	PTFE seals, graphite	
		Dosing head version	
	0	Without bleed valve, without valve spring	
	1	Without bleed valve, with valve spring	
		Hydraulic connection	
	0	Standard connection in line with technical data	
		Version	
	0	With ProMinent logo	
	2	Without ProMinent logo	
		Electrical connection	
	U	Universal control 100-230 V ±10 %, 50/60 Hz	
		Cable and plug	
	A	2 m European	
	B	2 m Swiss	
	C	2 m Australian	
	D	2 m USA	
	
		Relay	
	0	No relay	
	1	Fault indicating relay N/C	1 x changeover contact 230 V – 8 A

Product range delta[®], version a

3	Fault indicating relay magnetic	1 x changeover contact 230 V – 8 A
4	As 1 + pacing relay	2 x N/O 24 V – 100 mA
5	As 3 + pacing relay	2 x N/O 24 V – 100 mA
...	...	
Accessories		
0	No accessories	
Control versions		
0	Manual + external contact with pulse control	
3	Manual + external contact with pulse control + analog 0/4-20mA	
4	As 0 +14-day process timer	
5	As 3 +14-day process timer	
C	CANopen	
R	As 3 + PROFIBUS [®] interface, M12	
Access code		
0	No access code	
1	With access code	
Language		
DE	German	
EN	English	
FR	French	
ES	Spanish	
...	...	
Pause / level		
0	Pause N/C, level N/C	

2 About this pump

Properties of the device

The solenoid metering pumps belonging to the mikro delta® product range with controlled optoDrive® solenoid drive are micro-processor-controlled solenoid metering pumps with the following characteristics:

- Output range 150-1500 ml/h, 60 - 20 bar
- Lifting volume 1-250 µl
- Material versions PTFE and stainless steel
- Metering reproducibility: ±0.5 %
- Continuous or pulsing operation
- Adaptation of the pump to the feed chemical
- Continuous stroke length adjustment from 0 - 100 %
- Adjustment and display of the feed rate, either as strokes/min, strokes/h or l/h via the keyboard
- Large illuminated graphic display
- External activation via potential-free contacts with pulse step-up and step-down
- Option of external activation by standard signal 0/4-20 mA (optional)
- Interface for PROFIBUS® or CANopen (optional)
- 14-day process timer* for time- and event-dependent metering tasks (optional)
- Connection for 2-stage level switch
- 3 LED display for operation, LCD screen for warning and fault reporting in the display

3 Safety chapter





Explanation of the safety instructions

The following signal words are used in these operating instructions to denote different severities of danger:

Signal word	Meaning
WARNING	Denotes a possibly dangerous situation. If this is disregarded, you are in a life-threatening situation and this can result in serious injuries.
CAUTION	Denotes a possibly dangerous situation. If this is disregarded, it could result in slight or minor injuries or material damage.

Warning signs denoting different types of danger

The following warning signs are used in these operating instructions to denote different types of danger:

Warning signs	Type of danger
	Warning – automatic start-up.
	Warning – hand injuries.
	Warning – high-voltage.
	Warning – danger zone.

Correct and proper use

- The pump may only be used to dose liquid metering chemicals.
- The pump may only be started up after it has been correctly installed and commissioned in accordance with the technical data and specifications contained in the operating instructions.
- Observe the general limitations with regard to viscosity limits, chemical resistance and density - see also ProMinent-resistance list (In the product equipment catalogue or at www.prominent.com)!
- Any other uses or modifications are prohibited.
- The pump is not intended for the metering of gaseous media or solids.
- The pump is not intended for the metering of explosive media.
- The pump is not intended for operation in hazardous locations.
- The pump is not intended for exterior applications without use of suitable protective equipment.

- The pump should only be operated by trained and authorised personnel, see the following "Qualifications" table.
- You are obliged to observe the information contained in the operating instructions at the different phases of the device's service life.

Safety information



WARNING!

Warning about personal and material damage

The pump can start to pump, as soon as it is connected to the mains voltage.

- Install an emergency cut-off switch in the pump power supply line or integrate the pump in the emergency cut-off management of the system.



WARNING!

Danger of electric shock

A mains voltage may exist inside the pump housing.

- If the pump housing has been damaged, you must disconnect it from the mains immediately. It may only be returned to service after an authorised repair.



WARNING!

Warning of crushing of the fingers

The moving parts in the turret can crush fingers.

- The protective bush on the liquid end must always be closed when the pump is ready for operation.



WARNING!

Fire danger

Combustible media may only be transported using stainless steel dosing heads. In exceptional cases where this is not possible, PTFE with carbon can be used, whereby our TT_ versions are manufactured from this conducting plastic. Here, the operator is urged to take special care due to the low mechanical strength.



WARNING!

Warning of hazardous or unknown feed chemical

Should a hazardous or unknown feed chemical be used, it may escape from the hydraulic components when working on the pump.

- Take appropriate protective measures before working on the pump (protective eyewear, protective gloves, ...). Read the safety data sheet on the feed chemical.
- Drain and flush the liquid end before working on the pump.



CAUTION!

Warning of feed chemical spraying around

Feed chemical can spray out of the hydraulic components if they are manipulated or opened due to pressure in the liquid end and adjacent parts of the system.

- Disconnect the pump from the mains power supply and ensure that it cannot be switched on again by unauthorised persons.
- Depressurise the system before commencing any work on hydraulic parts.



CAUTION!

Warning of feed chemical spraying around

An unsuitable feed chemical can damage the parts of the pump contacted by the chemical.

- Take into account the resistance of the materials which will come into contact with the chemical when selecting the feed chemical - refer to the ProMinent resistance list in the product equipment catalogue under www.prominent.com.



CAUTION!

Warning of feed chemical spraying around

The metering pump can generate a multiple of its rated pressure. If a discharge line is blocked, hydraulic parts may burst.

- Correctly install a back pressure valve in the discharge line behind the metering pump.



CAUTION!

Small quantities of feed chemical can escape

Due to its design, small quantities of feed chemical escape at the piston. Therefore appropriate safety precautions must be taken if toxic media are being metered.

- If toxic feed chemicals are being metered, take appropriate safety precautions.
Observe the safety data sheet for the feed chemical.



CAUTION!

Danger of personnel injury and material damage

The use of untested third party parts can result in personnel injuries and material damage.

- Only fit parts to metering pumps, which have been tested and recommended by ProMinent.



CAUTION!

Danger from incorrectly operated or inadequately maintained pumps

Danger can arise from a poorly accessible pump due to incorrect operation and poor maintenance.

- Ensure that the pump is accessible at all times.
- Adhere to the maintenance intervals.



CAUTION!

Danger from incorrect metering

Should a different liquid end size be fitted, this will change the metering behaviour of the pump.

- Have the pump reprogrammed in the works.



CAUTION!

Warning of illegal operation

Observe the regulations that apply where the unit is to be installed.

Information in the event of an emergency

In the event of an electrical accident, disconnect the mains cable from the mains or press the emergency cut-off switch fitted on the side of the system!

If feed chemical exits, switch off the pump by pressing the *[Stop/Start]* key. If necessary depressurise the hydraulic system around the pump. Observe the safety data sheet for the feed chemical.

Qualification of personnel

Activity	Qualification level
Storage, transport, unpacking	Instructed person
Assembly, installation of hydraulic system	Technical personnel, service
Installation, electrical	Electrical technician
Operation	Instructed person
Maintenance, repair	Technical personnel, service
Decommissioning, disposal	Technical personnel, service
Troubleshooting	Technical personnel, electrical technician, instructed person, service

Explanation of the terms:

Technical personnel

A qualified employee is deemed to be a person who is able to assess the tasks assigned to him and recognise possible dangers based on his/her technical training, knowledge and experience, as well as knowledge of pertinent regulations.

Note:

A qualification of equal validity to a technical qualification can also be gained by several years' employment in the relevant work area.

Electrical technician

Electrical technicians are deemed to be people who are able to complete work on electrical systems and recognize and avoid possible dangers independently based on their technical training and experience, as well as knowledge of pertinent standards and regulations.

Electrical technicians should be specifically trained for the working environment in which they are employed and know the relevant standards and regulations.

Electrical technicians must comply with the provisions of the applicable statutory directives on accident prevention.

Instructed person

An instructed person is deemed to be a person who has been instructed and, if required, trained in the tasks assigned to him/her and possible dangers that could result from improper behaviour, as well as having been instructed in the required protective equipment and protective measures.

Customer Service department

Customer Service department refers to service technicians, who have received proven training and have been authorised by ProMinent or ProMaqua to work on the system.

Sound pressure level

Sound pressure level $L_{pA} < 70$ dB in accordance with EN ISO 20361:2010-10

at maximum stroke length, maximum stroke rate, maximum back pressure (water)

4 Storage, transport and unpacking

Safety information

**WARNING!****The pump can tip over when lifting**

The pump can tip over when lifting, as the centre of gravity of the pump is quite a distance from the liquid end.

- Grip the pump quite close to the liquid end.

Safety information

**WARNING!**

The transporting of pumps which have been used with radioactive feed chemicals is forbidden!

They will also not be accepted by ProMinent!

**WARNING!**

Only return metering pumps for repair in a cleaned state and with a flushed liquid end - refer to the section on decommissioning!

Only send metering pumps with a filled in Decontamination Declaration form. The Decontamination Declaration constitutes an integral part of an inspection / repair order. A unit can only be inspected or repaired when a Declaration of Decontamination Form is submitted that has been completed correctly and in full by an authorised and qualified person on behalf of the pump operator.

The "Decontamination Declaration Form" can be found in the Appendix or at www.prominent.com.

**CAUTION!****Danger of material damage**

The device can be damaged by incorrect or improper storage or transportation!

- The unit should only be stored or transported in a well packaged state - preferably in its original packaging.
- The packaged unit should also only be stored or transported in accordance with the stipulated storage conditions.
- The packaged unit should be protected from moisture and the ingress of chemicals.

Personnel: ■ Technical personnel

Ambient conditions

Data	Value	Unit
Minimum storage and transport temperature	-10	°C
Maximum storage and transport temperature	+50	°C
Air humidity	< 95	% rel. humidity*

* non-condensing

Scope of supply

Compare the delivery note with the scope of supply:

- Metering pump with mains power cable
- Connector kit for hose/pipe connection
- Edge pin (TT_ only)
- Product-specific operating instructions with EC Declaration of Conformity
- Relay cable, as necessary

5 Device overview and control elements

5.1 Device overview

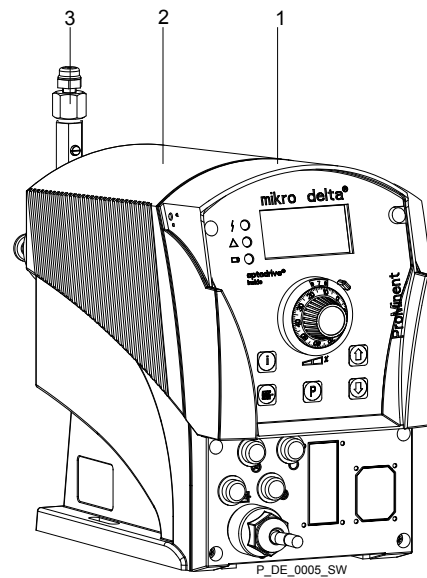

Fig. 2

- 1 Control unit
- 2 Drive unit
- 3 Liquid end

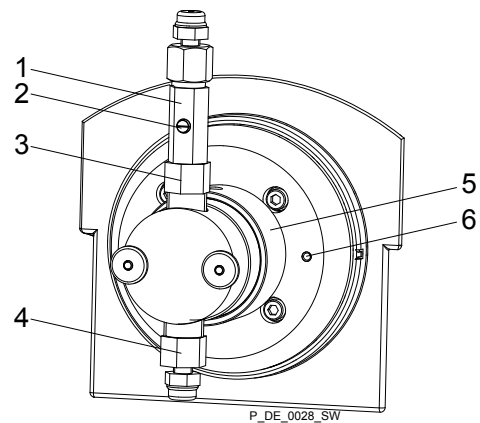

Fig. 3

- 1 Back pressure valve
- 2 Vent screw
- 3 Discharge valve
- 4 Suction valve
- 5 Protective bush
- 6 Threaded hole for grounding screw

5.2 Control elements

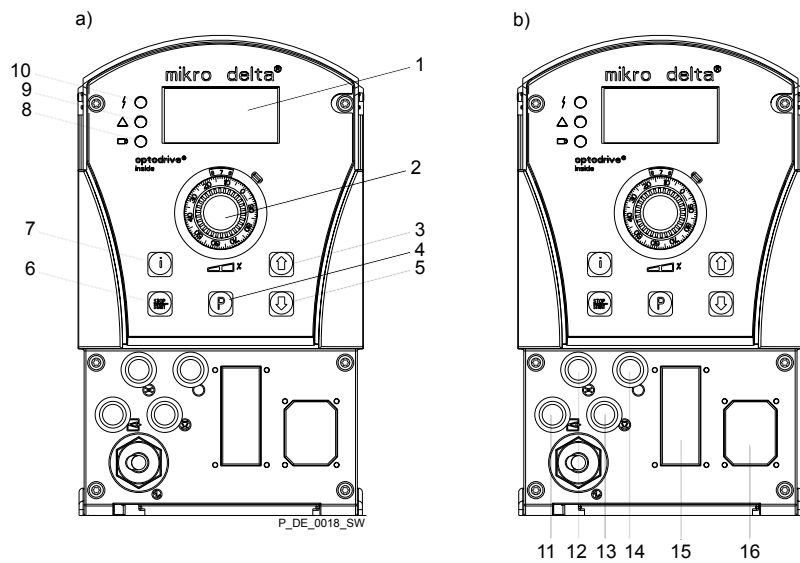





Fig. 4: a) Displays delta and keys, b) Electrical control connections

- 1 LCD display
- 2 Stroke length adjustment knob
- 3 Key [UP]
- 4 Key [P]
- 5 Key [DOWN]
- 6 Key [STOP/START]
- 7 Key [i]
- 8 Operating indicator (green)
- 9 Warning indicator (yellow)
- 10 Fault indicator (red)
- 11 "External control" jack
- 12 "Dosing monitor" jack
- 13 "Level Switch" jack
- 14 "Diaphragm rupture reporter" jack
- 15 Optional module slot (timer, PROFIBUS®, CAN-Bus)
- 16 Relay and mA-output (option)

5.2.1 Key functions

Key	Application	In continuous displays (operation)	In adjustment mode (set up)
			
[STOP/START]	Pressed briefly	Stop pump,	Stop pump,
		start pump	start pump
			
[P]	Pressed briefly	Start batch (only in 'Batch' operating mode), acknowledge fault	Confirm entry - jump to next menu point or to continuous display
	Pressed for 2 s	Change to adjustment mode	-
	Pressed for 3 s	-	Jump to continuous display

Key	Application	In continuous displays (operation)	In adjustment mode (set up)
			
[i]	Pressed 1x	Change between the continuous displays	Change between "Changing individual numbers" and "Changing a number"
	Pressed 2x	-	Under "Changing individual numbers": jump to the first number
	Press and hold	Change to the secondary display	-
			
[UP], [DOWN]	Individually pressed (until double arrow appears)	Changing directly changeable variables	Select another setting, change individual number or number. At the top end of a selection, effect similar to an ESC key.
	Pressed simultaneously	Suction (in continuous display "Stroke rate")	-

5.2.2 Stroke length adjustment knob

The stroke length can be adjusted using the stroke length adjustment knob and with it the volume per stroke.

5.2.3 Identifiers

The LCD screen supports the operation and adjustment of the pump with different identifiers:

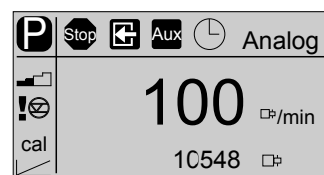











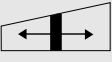









Fig. 5

The identifiers have the following meanings:

Symbol	Additional symbol	Name	Meaning
		Priming:	The pump is currently priming (both arrow keys pressed).
		Symbol for P-key:	The pump is in adjustment mode.
		Lock symbol:	Lock (if a code was set. Flashes).

Symbol	Additional symbol	Name	Meaning
		Double arrow symbol:	the value in the continuous display can be changed with the arrow keys.
i		Info symbol:	It is possible to change between continuous displays.
		Stop:	The pump was stopped using the [STOP/START] key (i.e. manually).
		Pause:	The pump was externally stopped by the Pause contact.
		Aux:	The pump is currently pumping with the auxiliary rate as the stroke rate. During this time, the pump is in operating mode 'Manual.'
		Fault:	A fault has occurred, which has stopped the system.
		Stroke length:	The pump is set to 'Dosing' 'slow' and this metering mode is also active (less than 61 strokes/min). Below 30 strokes/min the operating indicator flashes during operation and illuminates for slightly longer at the end of each stroke. The symbol relates to the symbol, which is located beneath the stroke adjustment dial.
		Stroke length adjustment:	Deviation in the stroke length from the value set at the time of the last locking of the adjustment menu.
		Level:	The "Warning" level in the storage tank was under-shot. If the symbol flashes, the level has fallen below the "Fault" level in the storage tank and the pump stops.
		Flow:	A flow control is connected. Together with a call sign, the symbol indicates problems with the flow.
		Contact:	The pump is in operating mode 'Contact'. The symbol closes every time a contact signal is generated.
		Contact signal:	The pump is in operating mode 'Batch'. The symbol flashes every time a contact signal is generated.
m		Memory:	The pump is in operating mode 'Contact' or 'Batch': the auxiliary function "Memory" has been set.
0..20		0...20 mA:	The pump is in operating mode 'Analog'. The processing type '0...20' is set.
4..20		4...20 mA:	The pump is in operating mode 'Analog'. The processing type '4...20' is set.
i < 4		i less than 4 mA:	Problems with the standard signal at the standard signal input e.g. broken cable.
i > 23		i greater than 23 mA:	The standard signal at the standard signal input indicates a fault with the connected unit.

Symbol	Additional symbol	Name	Meaning
		Line:	The pump is in operating mode 'Analog'. The processing type 'Curve'- 'Line' is set.
		Upper sideband:	The pump is in operating mode 'Analog'. The processing type 'Curve'- 'Upper sideband' is set.
		Lower sideband:	The pump is in operating mode 'Analog'. The processing type 'Curve'- 'Lower sideband' is set.



The pump only shows the metering volume and the capacity in the calibrated state in ml or ml/h.

6 Functional description

6.1 Liquid end

The dosing process is performed as follows: The piston is pressed into the dosing head; the pressure in the dosing head closes the suction valve and the feed chemical flows through the discharge valve out of the dosing head. The piston is now drawn out of the dosing head; the discharge valve closes due to the negative pressure in the dosing head and fresh feed chemical flows through the suction valve into the dosing head. One cycle is thus completed.

6.2 Drive unit

The displacement body is driven by an electromagnet, which is controlled by an electronic control.

optoDrive® drive technology

The optoDrive® drive technology means the variation over time of the metering flow can be precisely matched to the requirements of the particular application. Hence the user can, dependent on requirements, set a slow discharge stroke for nearly continuous metering or a quick stroke e.g. for quick clocked filling processes. In both operating modes it is possible, to selectively also slow the suction stroke, see figure. In this way, it is possible to prevent the main cause for imprecise metering with high viscosity feed chemicals, namely the incomplete filling of the liquid end. For the case of gaseous feed chemicals, the slow suction stroke prevents cavitation and consequently increases metering accuracy. Oscillations in the back pressure in the metering line, which could lead to undesirable variations in the metering volume, are automatically compensated for by the drive. Consequently, a dosing precision is attained, which otherwise could only be achieved using a complex control circuit.

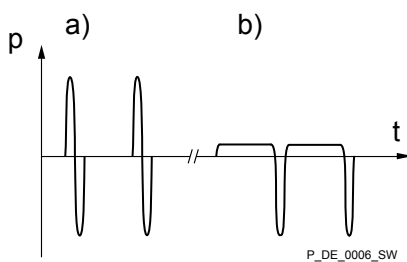

Fig. 6: Metering types: a) pulsing, b) nearly continuous

6.3 Capacity

The capacity is determined by the stroke length and rate.

The stroke length is adjusted by the stroke length adjustment knob within a range of 0 ... 100 %. A stroke length of between 4 ... 100 % is recommended to achieve the specified reproducibility.

The stroke rate can be set using the arrow keys (not in "Analog" operating mode) in the range 0 - 100 strokes/min (100 strokes/min $\hat{=}$ 6000 strokes/h). The "Stroke rate (strokes / min)" continuous display shows decimal places if a stroke frequency is set in the "Stroke rate (strokes / h)" continuous display, which cannot be divided by 60 without a remainder.

Data	Value	Unit
Recommended stroke length	4 ... 100	%

The stroke speed can be set in the "Dosing" menu.

6.4 Operating modes

Operating modes are selected via the "Operating modes" menu.

"Manual" operating mode

The stroke rate is set manually via the control unit.

"Batch" operating mode

This operating mode provides the option of working with large transfer factors (up to 65535). Metering can be triggered by pressing the button *[P]* or by a pulse received via the "External control" jack through a contact or a semiconductor switching element. A metering volume (batch) or a number of strokes can be selected in the '*Settings*' menu using the *[arrow keys]*.

Operating mode "Contact"

This operating mode offers the option of activating the pump externally by means of potential-free contacts (e.g. by means of a contact water gauge). The number of strokes (reducing or transfer factor 0.01 to 99.99) can be pre-selected in the '*Settings*' menu using the *[arrow keys]*.

"Analog" operating mode

The stroke rate is controlled using an analog current signal via the "External control" jack. Processing of the current signal can be pre-selected via the control unit.

6.5 Functions

The following functions can be selected via the menu '*Settings*' :

"Calibrate" function

The stroke rate is controlled using an analog current signal via the "External control" jack. Processing of the current signal can be pre-selected via the control unit.

The pump can also be operated in the calibrated state in all operating modes. The corresponding continuous displays can then either display the metering volume or the capacity (in the 2nd level continuous display). The calibration remains valid over the entire stroke rate range and over a stroke length range from 0 - 100 %.

"Auxiliary rate" function

This enables switching to an adjustable stroke rate which can be fixed in the '*Settings*' menu via the "External control" jack. This auxiliary frequency has priority over the operating mode stroke rate settings.

"Flow" function

Currently no suitable dosing monitor is available.

The following functions are available as standard:

"Level switch" function	Information about the liquid/powder level in the feed chemical container is reported to the pump. To do so, a two-stage level switch must be fitted; it is connected to the "Level switch" jack.
"Pause" function	The pump can be remotely stopped via the "External control" jack. The following functions are triggered by a key press:
"Stop" function	The pump can be stopped by pressing the key <i>[STOP/START]</i> , without disconnecting it from the power supply.
"Priming" function	Priming (short-term transport at maximum frequency) can be triggered by simultaneous pressing of the two <i>[arrow keys]</i> .

6.6 Relay (options)

The pump has several connection options for:

"Fault indicating relay" option	The relay can, in the event of fault or warning alerts or messages (e.g. <i>'Warning level'</i>), close a connected electric circuit (e.g. for an alarm horn). The relay can be retrofitted through a knock-out opening in the pump foot - refer to "Retrofitting relays".
"Fault indicating and pacing relay" option	This combined relay can generate a contact with each stroke via its pacing relay in addition to its function as a fault indicating relay. The relay can be retrofitted through a knock-out opening in the pump foot - refer to "Retrofitting relays".
"mA output" option	The I signal of the current output signals the currently calculated pump metering volume. The option "mA output" can be retrofitted via a knock-out in the control unit. The option additionally always provides a fault indicating relay or a pacing relay.

6.7 Functional and fault Indicator

The operating and fault statuses are indicated by the three LED indicators and the "Fault" identifier of the LCD screen, see also the "Troubleshooting" chapter.

6.8 LCD display

If a fault occurs, the identifier "Fault" appears as well an additional, explanatory symbol.

6.9 LED indicators

Fault indicator (red)

The fault indicator lights up if the liquid level in the chemical feed container falls below the second switching point of the level switch (20 mm residual filling level in the chemical feed container).

This LED flashes in the event of an undefined operating mode.

Warning indicator (yellow)

The warning indicator lights up if the fluid level in the chemical feed container falls below the first switching point of the level switch.

Operating indicator (green)

The operating indicator lights up if the pump is ready for operation and there are no fault or warning alerts. It goes out quickly as soon as the pump has performed a stroke. It starts to flash as soon as the stroke rate falls below 30 strokes / min.

6.10 Hierarchy of operating modes, functions and fault statuses

The different operating modes, functions and fault statuses have a different effect on if and how the pump reacts.

The following list shows the order:

1. - Priming
2. - Fault, Stop, Pause
3. - Auxiliary rate
4. - Manual, Analog, Contact, Batch

Comments:

- re 1 - "Priming" can take place in any mode of the pump (providing it is functioning).
- re 2 - "Fault", "Stop" and "Pause" stop everything apart from "Priming".
- re 3 - The stroke rate of "Auxiliary rate" always has priority over the stroke rate specified by an operating mode or priority 4.

7 Assembly



WARNING!

Danger of electric shock

If water or other electrically conducting liquids penetrate into the drive housing, in any other manner than via the pump's suction connection, an electric shock may occur.

- Position the pump so that it cannot be flooded.



CAUTION!

Danger from incorrectly operated or inadequately maintained pumps

Danger can arise from a poorly accessible pump due to incorrect operation and poor maintenance.

- Ensure that the pump is accessible at all times.
- Adhere to the maintenance intervals.



Capacity too low

The liquid end valves can be disrupted by vibrations.

- *Secure the metering pump so that no vibrations can occur.*



Capacity too low

If the valves of the liquid end do not stand vertically upwards, they cannot close correctly.

- *Suction and discharge valves must stand vertically upwards (for self-bleeding liquid end, the bleed valve).*

- Mount the metering pump with the pump foot on a horizontal, level and load-bearing supporting surface.

8 Hydraulic installation

Notes



CAUTION!

Small quantities of feed chemical can escape

Due to its design, small quantities of feed chemical escape at the piston. Therefore appropriate safety precautions must be taken if toxic media are being metered.

- If toxic feed chemicals are being metered, take appropriate safety precautions.
Observe the safety data sheet for the feed chemical.



CAUTION!

Escaping feed chemical

If the vent screw is open, feed chemical escapes.

- As necessary, implement suitable protective measures.
- Observe the safety data sheet for the feed chemical.



CAUTION!

Warning of backflow

A back pressure valve or a spring-loaded injection valve do not represent absolutely leak-tight closing elements.

- For this purpose use a shut-off valve, a solenoid valve or a vacuum breaker.



Suction side installation

- *Keep the suction line as short as possible.*
- *Route the suction line so that it has a constant upwards slope in order to prevent gas collecting in it.*
- *The pump cannot be primed against pressure. For this purpose, open the vent screw, provided the properties of the feed chemical permit.
If they do not permit it, arrange the system accordingly.*

Screwing the back pressure valve on to the discharge valve

1. ➤ First screw the valve on finger-tight.
2. ➤ Tighten the valve according to the following table.

Material version	Tightening instruction
TT_	approx. 30 ... 45°
SS_	approx. 45° or approx. 8 Nm

Installing PTFE hose on TT-liquid end

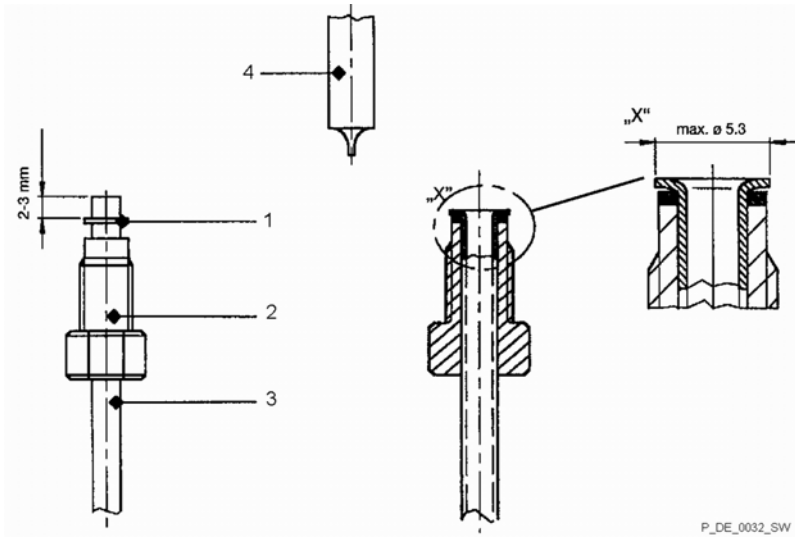

Fig. 7: Installing PTFE hose on TT-liquid end

- 1 Slide ring
- 2 Screw ring, connection thread UNF 1/4"-28
- 3 PTFE hose
- 4 Edge pin

1. ➔ Push the screw fitting (2) and the slide ring (1) on to the PTFE hose (3).
2. ➔ Heat the edge pin (4) (within the scope of delivery) to approx. 60 ... 80 °C.

i – Do not kink the hose in the following step!
 – To press on, use e.g. anti-skid emery paper or similar.

3. ➔ Press the hose with the screw fitting and the slide ring onto the hot edge pin.

Data	Value
Connection thread for screw fitting	UNF 1/4"-28

Installing PTFE hose on stainless steel liquid end

i Max. operating pressure 6 bar for 1/8" and 1/16" PTFE hose, valid for connector system on pipe nipple with mikro delta®.

- ➔ Plug the PTFE hose onto the pipe nipple.

Installing stainless steel pipe

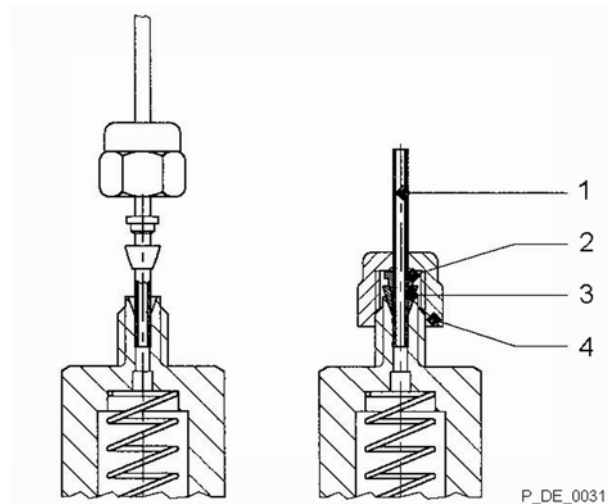

Fig. 8: Installing stainless steel pipe

- 1 Stainless steel pipe 1/8" or 1/16"
- 2 Thrust collar 1/8" or 1/16"
- 3 Tensioning collar 1/8" or 1/16"
- 4 Connecting nut 1/8" or 1/16"

Preparation:

Remove the hose with the nipple from the liquid end.

1. ➤ Push the connecting nut, thrust collar and the tensioning collar onto the pipe.
2. ➤ Push the pipe end right into the hole.
3. ➤ Place the tensioning collar and the thrust collar on the connection.
4. ➤ Position the connecting nut and tighten.

9 Electrical installation



WARNING!

Danger of electric shock

A mains voltage may exist inside the device.

- Before any work, disconnect the device's mains cable from the mains.



WARNING!

Risk of electric shock

This pump is supplied with a grounding conductor and a grounding-type attachment plug.

- To reduce the risk of electric shock, ensure that it is connected only to a proper grounding-type receptacle.



WARNING!

Risk of electric shock

In the event of an electrical accident, the pump must be quickly disconnected from the mains.

- Install an emergency cut-off switch in the pump power supply line or
- Integrate the pump in the emergency cut-off management of the system and inform personnel of the isolating option.



WARNING!

Danger of electric shock

Incompletely installed electrical options can allow moisture into the inside of the housing.

- Knock-out openings in the pump housing must be equipped with matching modules or be sealed in a leak-tight manner.



WARNING!

Danger of electric shock

A mains voltage may exist inside the pump housing.

- If the pump housing has been damaged, you must disconnect it from the mains immediately. It may only be returned to service after an authorised repair.

**CAUTION!****Risk of short circuiting caused by moist pins**

No moisture must reach the pins of the PROFIBUS® jack.

- A suitable PROFIBUS® plug or protective cap must be screwed onto the PROFIBUS® jack.

**CAUTION!****Material damage possible due to power surges**

Should the pump be connected to the mains power supply in parallel to inductive consumers (such as solenoid valves, motors), inductive power surges can damage the controller when it is switched off.

- Provide the pump with its own contacts and supply with voltage via a contactor relay or relay.

Personnel: ■ Electrician

- Install the pump technically correctly and in accordance with the operating instructions and applicable regulations.

9.1 Supply voltage connector

**WARNING!****Unexpected startup is possible**

As soon as the pump is connected to the mains, the pump may start pumping and consequently feed chemical may escape.

- Prevent dangerous feed chemicals from escaping.
- If you have not successfully prevented this, immediately press the *[STOP/START]* key or disconnect the pump from mains, e.g. via an emergency cu-off switch.

**CAUTION!**

If the pump is integrated into a system: The system must be designed so that potential hazardous situations are avoided by pumps starting up automatically subsequent to unintended power interruptions.

Connect the pump to the mains power supply using the mains cable.

9.2 Description of the jacks

9.2.1 "External control" terminal

The "external control" jack is a five-pin panel jack. It is compatible with two- and four-conductor cables.

The "Auxiliary frequency" and "mA-output" functions can only be used with a five conductor cable.

Electrical interface for pin 1 "Pause" - pin 2 "External contact" - pin 5 "Auxiliary frequency"

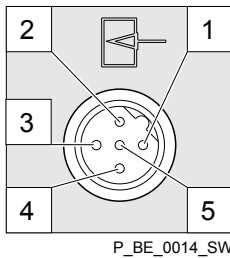

Fig. 9: Pump pin assignments

Data	Value	Unit
Voltage with open contacts	5	V
Input resistance	10	kΩ
Max. pulse frequency	25	pulse/s
Minimum pulse duration	20	ms

Control via:

- potential-free connection contact (load: 0.5 mA at 5 V) or
- Semiconductor switch (residual voltage < 0.7 V)

Electrical interface for pin 3 "mA output" (identity code characteristic "Control variant": 3, 5 and R)¹

Data	Value	Unit
Input apparent ohmic resistance, approx.	120	Ω

¹ The metering pump makes its first metering stroke at approx. 0.4 mA (4.4 mA) and starts continuous operation at approx. 19.2 mA.

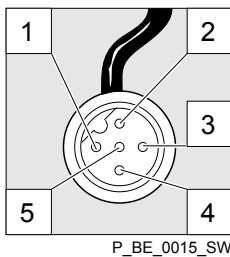

Fig. 10: Cable conductor assignments

Pin	Function	5-conductor cable	2-conductor cable
1	Pause	brown	bridged at pin 4
2	External contact	white	brown
3	mA output*	blue	-
4	Earth / GND	black	white
5	Auxiliary frequency	grey	-

* with identity code characteristic "Control version": 3, 5 and R



Refer to the functional description for the hierarchy of functions and operating modes.

"Pause" function

The pump does not work if:

- the cable is connected and pin 1 and pin 4 are open.

The pump works if:

- the cable is connected and pin 1 and pin 4 are connected.
- no cable is connected.

"External contact" operating mode

The pump performs one or more strokes if:

- Pin 2 and pin 4 are connected to each other for at least 20 ms. At the same time, pin 1 and pin 4 must also be connected to each other.

"Auxiliary frequency" operating mode

The pump works at a preset stroke rate if:

- Pin 5 and pin 4 are connected to each other. At the same time, pin 1 and pin 4 must also be connected to each other. The auxiliary frequency is factory-preset to the maximum stroke rate.

9.2.2 "Level Switch" terminal

There is a connecting option for a 2-stage level switch with pre-warning and limit stop.

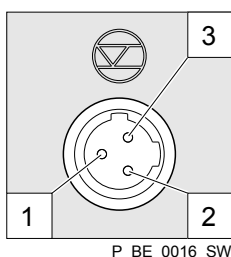

Fig. 11: Pump pin assignments

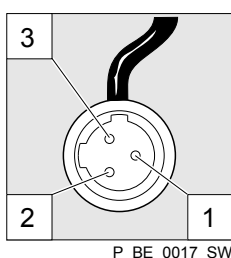

Fig. 12: Cable conductor assignments

Electrical interface

Data	Value	Unit
Voltage with open contacts	5	V
Input resistance	10	kΩ

Control via:

- potential-free connection contact (load: 0.5 mA at 5 V) or
- Semiconductor switch (residual voltage < 0.7 V)

Pin	Function	3-conductor cable
1	Earth / GND	black
2	Minimum pre-warning	blue
3	Minimum limit stop	brown

9.2.3 "Dosing monitor" terminal

There is a connecting option for a dosing monitor.

Electrical interface

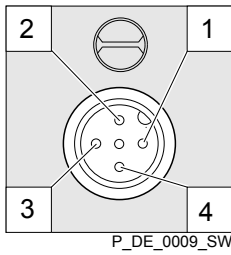

Fig. 13: Pump pin assignments

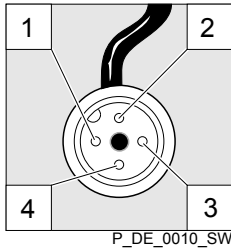

Fig. 14: Cable conductor assignments

Data	Value	Unit
Voltage with open contacts	5	V
Input resistance	10	kΩ

Control via:

- potential-free connection contact (load: 0.5 mA at 5 V) or

Pin	Function	4-conductor cable
1	Power supply (5 V)	brown
2	Coding	white
3	Feedback	blue
4	Earth / GND	black

9.3 Relay

9.3.1 "Fault indicating relay" output (identity code 1 + 3 or 4 + 5)

A fault indicating relay can be ordered as an option - refer to ordering information in the appendix. It is used to emit a signal when there is a fault with the pump and with "Liquid level low, 1st stage" warning alert and "Liquid level low 2nd stage" fault alert.

A cut-off relay works when there are fault alerts from the pump and in the event of the "Liquid level low 2nd stage" fault alert.

The fault indicating relay can be retrofitted and is operational once attached to the relay board - refer to "Retrofitting Relays" in the Appendix.

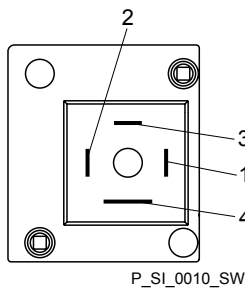

Fig. 15: Pump pin assignments

Identity code 1 + 3

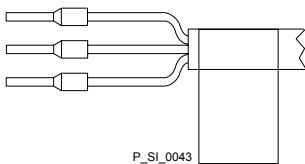

Fig. 16: Cable conductor assignments

Electrical interface

Data	Value	Unit
Maximum contact load at 230 V and 50/60 Hz:	8	A
Minimum mechanical lifespan:	200 000	Switching operations

Pin assignment

To pin	VDE cable	Contact	CSA cable
1	white	NO (normally open)	white
2	green	NC (normally closed)	red
4	brown	C (common)	black

Identity code 4 + 5

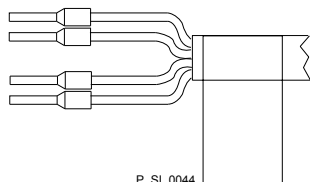

Fig. 17: Cable conductor assignments

Pin assignment

To pin	VDE cable	Contact	Relay
1	yellow	NO (normally open)	Fault indicating relay
4	green	C (common)	Fault indicating relay
3	white	NO (normally open)	Pacing relay
2	brown	C (common)	Pacing relay

9.3.2 Output pacer relay (identity code 4 + 5)

A fault indicating and a pacing relay can optionally be ordered - refer to ordering information in the appendix. The pacing output is electrically-isolated by means of an optocoupler with a semiconductor switch. The second switch is a relay.

The fault indicating/pacing relay can be retrofitted and is operational once attached to the relay board - refer to "Retrofitting Relays" in the Appendix.

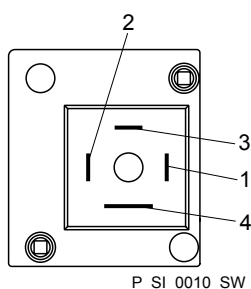

Fig. 18: Pump pin assignments

Electrical interface

for semiconductor switch pacing relay:

Data	Value	Unit
Maximum residual voltage at $I_c = 1 \text{ mA}$	0.4	V
Maximum current	100	mA
Maximum voltage	24	VDC
Pacing pulse duration, approx.	100	ms

Identity code 4 + 5

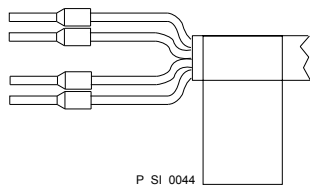

Fig. 19: Cable conductor assignments

Pin assignment

To pin	VDE cable	Contact	Relay
1	yellow	NO (normally open)	Fault indicating relay
4	green	C (common)	Fault indicating relay
3	white	NO (normally open)	Pacing relay
2	brown	C (common)	Pacing relay

10 Set-up



- Please read the overviews in the appendix, "Control elements and key functions" and "Operating/setting diagram" for supplementary information.
- If no key is pressed for a 1 minute duration, the pump returns to a continuous display.

10.1 Basic principles of control adjustment

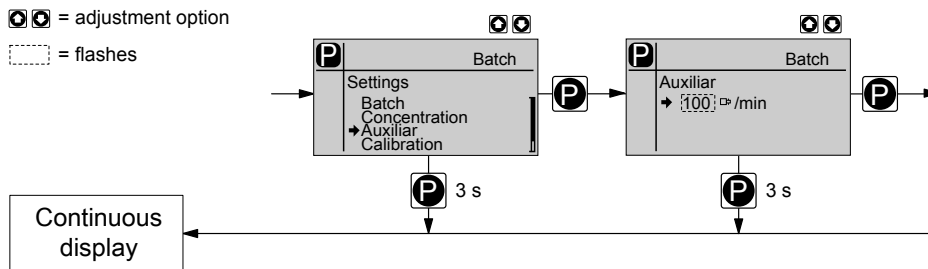

Confirming an entry

Quickly press key **[P]**.

The display simultaneously changes to the next selection, to the next menu option or into a continuous display.

Quitting a menu option without confirming it

Press the **[UP]** key in the top menu selection, if no entry has been started (flashing beam).

You will jump back to the previous menu point or menu, at most back to the main menu.

Jumping back to a continuous display

Press and hold the **[P]** key for 3 seconds.

Entry is cancelled and you jump back to a continuous display.

Changing adjustable values

Press the arrow keys **[UP]** or **[DOWN]**.

In this way the number between the flashing bars counts upwards or downwards.

Confirming adjustable values

Under "Changing a number": press key **[P]** 1x.

The display simultaneously changes to the next selection, to the next menu option or into a continuous display.

10.2 Checking adjustable values

Continuous displays

Before you adjust the pump, you can check the actual settings of the adjustable variables:

- ➔ Press the key *[i]* ("i" for "Info"), if the pump is displaying a continuous display (The display does not contain the symbol for the *[P]* key).
 - ⇒ Each time you press the *[i]* key, you see another continuous display, an "i" can be seen at the top left.



The number of continuous displays depends on the identity code, the selected operating mode and the connected additional devices, see overview "Continuous displays" in the appendix.

Secondary displays

The lowest line of the Info displays (2nd level continuous display) various information, which cannot, however, be adjusted here, see overview "Secondary displays" in the appendix...

If you are in a continuous display, you can access the bottom line of the info displays by:

1. ➔ pressing key *[i]*, provided that the top left double arrow is not visible.
2. ➔ Keep key *[i]* pressed down until a small arrow appears and glides into the bottom line of the LCD display.
3. ➔ As soon as it has reached it, quickly release the *[i]* key and immediately page through the info displays in the bottom line by quickly pressing the *[i]* key.

10.3 Changing to adjustment mode

If the *[P]* key is pressed for 2 seconds in a continuous display, the pump changes to adjustment mode. If *[Lock menu]* or *'Lock all'* have been set under *'Security'* (top left lock symbol), the *[P]* key must be pressed and then the access code entered (*[arrow keys]*).

The following menus can be initially chosen in adjustment mode - see also the overview "Operating/setting diagram":

- Menu *'Operation'*
- Menu *'Settings'*
- Menu *'Security'* (option)
- Menu *'Delete'*
- Menu *'Language'*

To adapt the pump to your process requirements, you must:

1. ➔ Select the operating mode in the *'Operation'* menu.
2. ➔ Carry out the adjustment for this operating mode under the *'Settings'* menu.

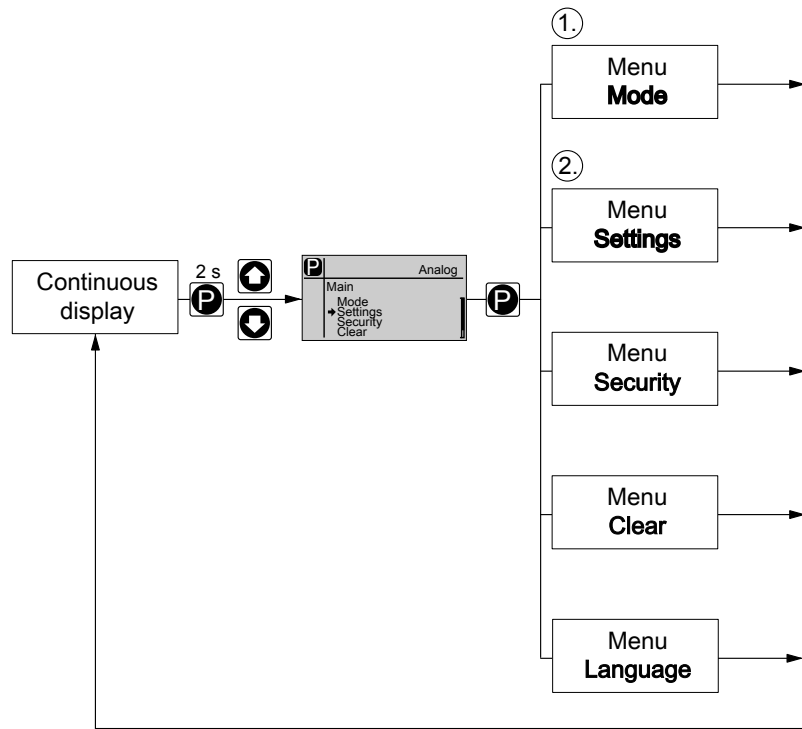

10.4 Selecting the operating mode (Menu "Operation")

In the 'Operation' menu (dependent on the identity code, some operating modes may not be present) the following operating modes can be selected:

- 'Manual': for manual operation
- 'Batch': for batch operation
- 'Contact': for contact operation
- 'Analog': for current control

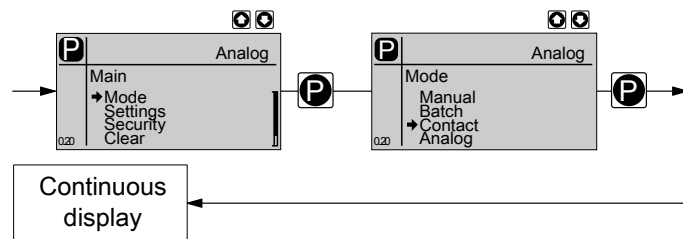

10.5 Operating mode settings (menu "Settings")

Various settings can be adjusted in the 'Settings' menu dependent on the selected operating mode.

Setting menus are available in all operating modes for the following programmable functions:

- 'Auxiliary frequency'
- 'Calibrate'

- 'Dosing'
- 'System'

For further details, see [Chapter 10.6 'Programmable function settings \("Settings" menu \)'](#) on page 44

As to whether or not a further setting menu is available, depends on the selected operating mode and the connected devices or modules.

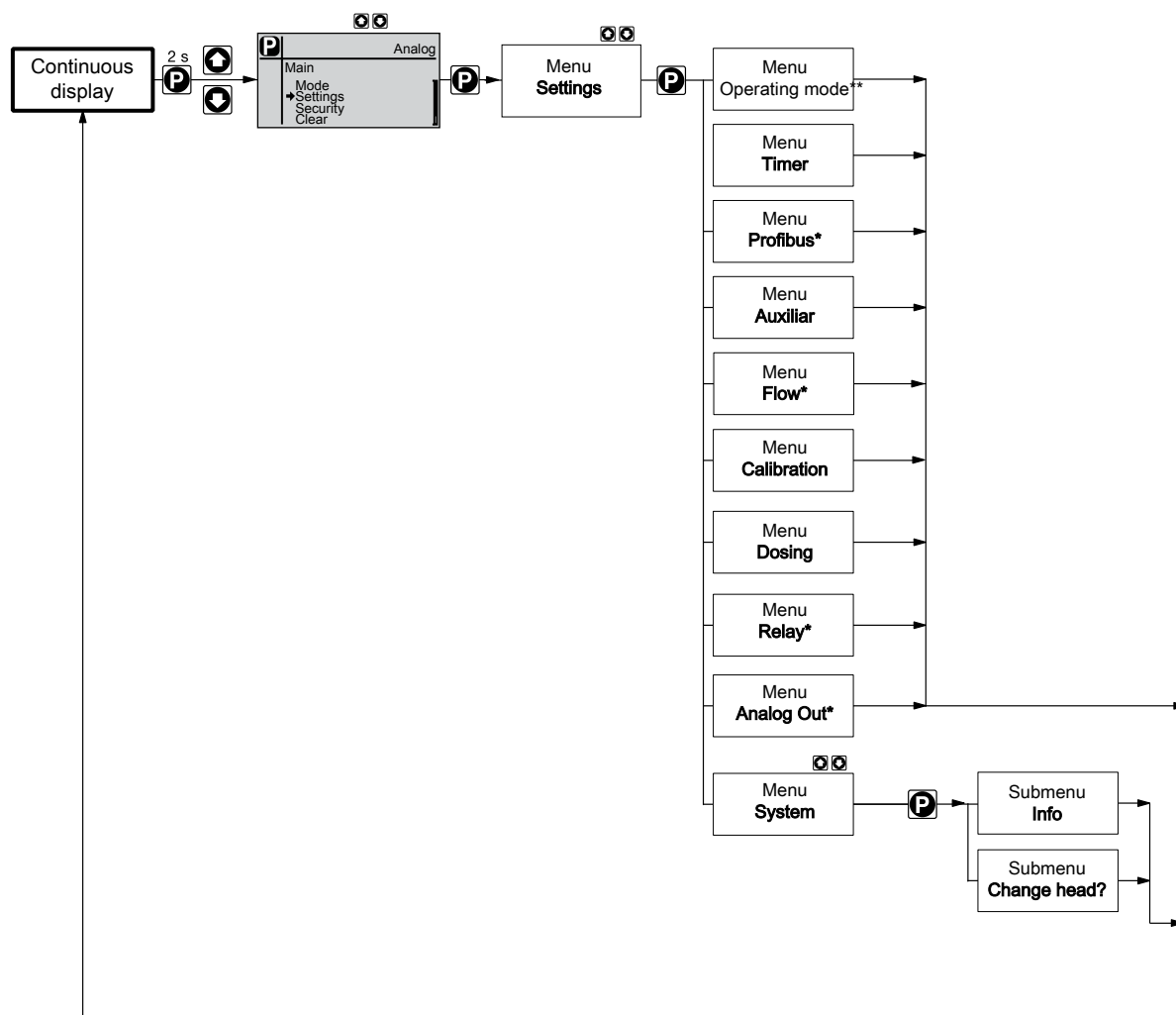

Fig. 20: "Settings" menu branch

10.5.1 "Manual" operating mode settings

Alongside the setting menu, which are described in more detail in [Chapter 10.6 'Programmable function settings \("Settings" menu \)'](#) on page 44, in 'Manual' operating mode in the 'Settings' menu there is no further setting menu available.

10.5.2 Settings for the "Batch" operating mode (BATCH menu)

Alongside the setting menus, which are described in more detail in [Chapter 10.6 'Programmable function settings \('Settings' menu\)'](#) on page 44, in 'Batch' operating mode in the 'Settings' menu, the 'BATCH' menu is also available.

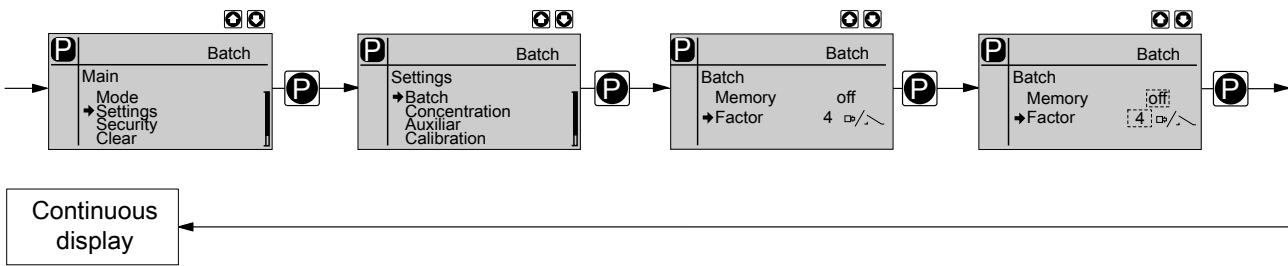

The operating mode 'Batch' is one variant of the 'Contact' operating mode - see the following chapter. Here also, you can select a number of strokes (no fractions, only integers from 1 to 65535).

Operating mode 'Batch' is intended for large metering quantities.

Metering can be triggered by pressing the [P] key or via an pulse received via the "External Control" jack.

The number of received pulses, which could not yet be processed, is stored by the pump in the stroke memory.



CAUTION!

When changing over from the "Manual" operating mode to the "Batch" operating mode, the pump maintains the stroke rate.



The stroke rate can also be set in 'Contact' operating mode. It should normally be set to 100 strokes / min.



In operation, the batch size can be changed more easily by using 'Batch size' in the continuous display:

1. Using the [i] key, select the "Batch size" continuous display (displays an '↑L' after the number).
2. Hold down an [arrow key] until the variable is flanked by two flashing bars.
3. Change the batch size as required using the [arrow keys].

"Memory" function extension

Additionally, you can activate the "Memory" function extension (Identifier "m"). When "Memory" is activated, the pump adds up the remaining strokes, which could not be processed, up to the maximum capacity of the stroke memory of 65,535 strokes. If this maximum capacity is exceeded, the pump goes into fault mode.

10.5.3 "Contact" operating mode settings

Alongside the setting menus, which are described in more detail in [Chapter 10.6 'Programmable function settings \('Settings' menu \)' on page 44](#), in 'Contact' operating mode in the 'Settings' menu, the 'Contact' menu is also available.

'Contact' operating mode allows you to trigger individual strokes or a stroke series.

You can trigger the strokes via a pulse sent via the "External control" terminal.

The purpose of this operating mode is to convert the incoming pulses with a reduction (fractions) or small step-up into strokes.



CAUTION!

When changing over from 'Manual' operating mode to 'Contact' operating mode, the pump maintains the stroke rate.



The stroke rate can also be set in 'Contact' operating mode. It should normally be set to 100 strokes / min.

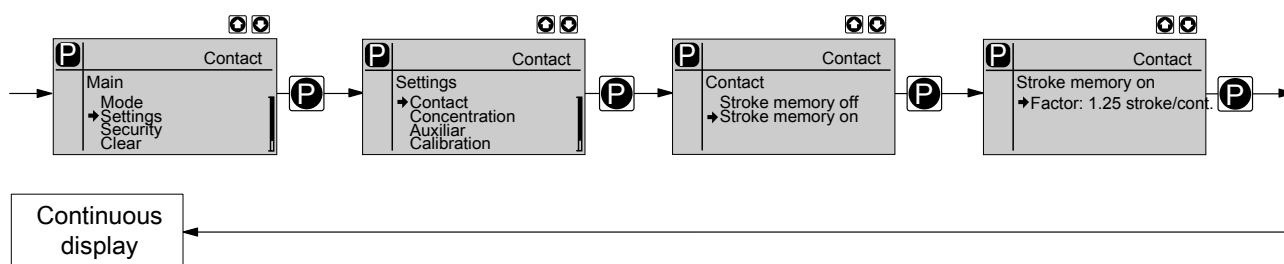

The number of strokes per pulse depends on the factor which you input. By use of the factor you can multiply incoming pulses by a factor between 1.01 and 99.99 or reduce them by a factor of 0.01 to 0.99.

Number of strokes executed = factor x number of incoming pulses

Example table

	Factor	Pulse (sequence)	Number of strokes (sequence)
Step-up*			
	1	1	1
	2	1	2
	25	1	25
	99.99	1	99.99
	1.50	1	1.50 (1 / 2)
	1.25	1	1.25 (1 / 1 / 1 / 2)
Reduction**			
	1	1	1
	0.50	2	1
	0.10	10	1
	0.01	100	1
	0.25	4	1
	0.40	2.5 (3 / 2)	(1 / 1)
	0.75	1.33 (2 / 1 / 1)	(1 / 1 / 1)

* Explanation of the conversion ratio

With a factor of 1,	... 1 stroke is executed per 1 pulse.
With a factor of 2,	... 2 strokes are executed per 1 pulse.
With a factor of 25,	... 25 strokes are executed per 1 pulse.

** Explanation of reduction

With a factor of 1,	... 1 stroke is executed per 1 pulse.
With a factor of 0.5,	...1 stroke is executed after 2 pulses.
With a factor of 0.1,	...1 stroke is executed after 10 pulses.
With a factor of 0.75,	...1 stroke is executed once after 2 pulses, then 1 stroke is executed after 1 pulse two times, and then again 1 stroke after 2 pulses etc.



If a remainder is obtained when dividing by the factor, then the device adds the remainders together. As soon as this sum reaches or exceeds "1", the pump executes an additional stroke. Therefore on average during the metering operation, the resultant number of strokes precisely matches the factor.

Non-processed pulses

The number of received pulses, which could not yet be processed, is stored by the pump in the stroke memory. When the *[STOP/START]* key is pressed or the "Pause" function is activated, the stroke memory is deleted. You can avoid this with the "Memory" function extension:

"Memory" function extension

Additionally, you can activate the "Memory" function extension (Identifier "m"). When "Memory" is activated, the pump adds up the remaining strokes, which could not be processed, up to the maximum capacity of the stroke memory of 65,535 strokes. If this maximum capacity is exceeded, the pump goes into fault mode.

Contact water meter

With "Pulse control" you can optimally adapt the pump to the relevant process, for example in conjunction with contact water meters.

10.5.4 "Analog" operating mode settings

Alongside the setting menus, which are described in more detail in *Chapter 10.6 'Programmable function settings ('Settings' menu)'* on page 44, in 'Analog' operating mode in the 'Settings' menu, the 'ANALOG' menu is also available. The stroke rate is controlled using an analog current signal via the "External control" terminal. The continuous display "Signal current" of the 2nd level indicates the incoming current.

You can select three types of current signal processing:

- '0 - 20 mA'
- '4 - 20 mA'
- 'Curve'

0 - 20 mA

At 0 mA the pump is stationary -

At 20 mA the pump works at the maximum stroke rate.

Between these values, the stroke rate is proportional to the current signal.

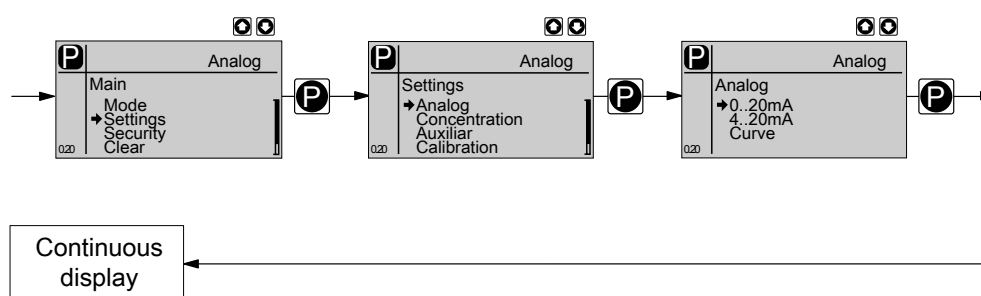
**4 - 20 mA**

At 4 mA the pump is stationary -

At 20 mA the pump works at the maximum stroke rate.

Between these values, the stroke rate is proportional to the current signal.

For current signals less than 3.8 mA a fault message appears and the pump stops (e.g. if a cable has broken).

i The maximum stroke rate can only be reduced under processing type 'Curve', not under processing types "0 .. 20" and "4 .. 20".

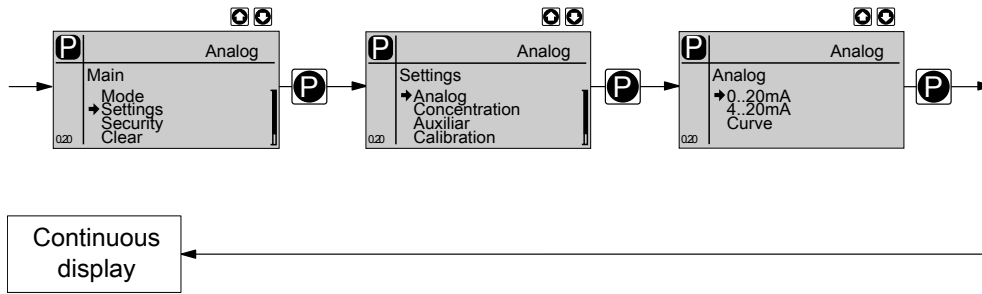

Curve

In the processing type 'Curve' you can freely program the pump behaviour.

There are three options:

- Linear
- Lower sideband
- Upper sideband

i The following applies to all three options:
The smallest processable difference between I1 and I2 is 4 mA (|| I1-I2 || ≥ 4 mA).

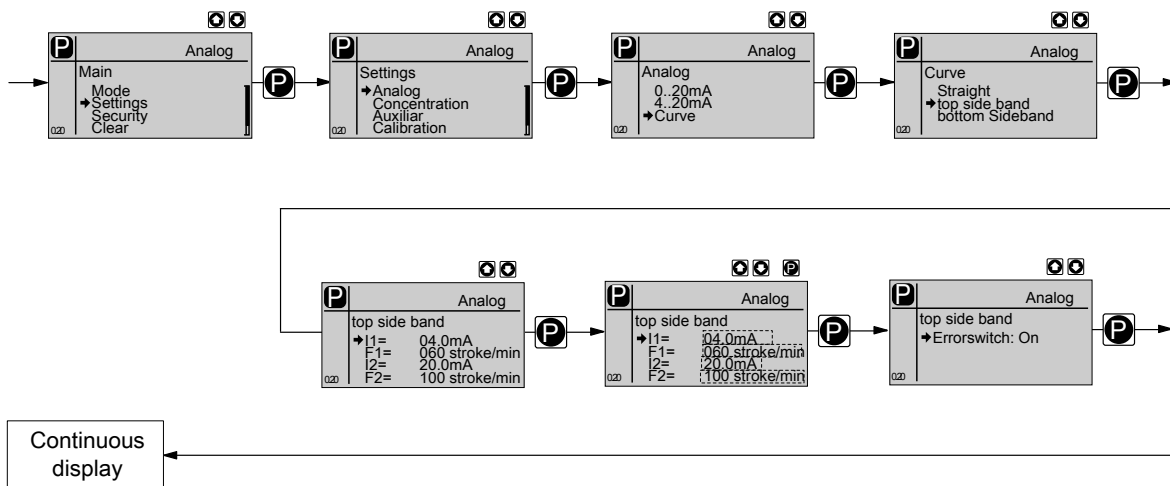

Linear

The "Linear" symbol appears in the LCD display. You can enter any stroke rate- behaviour of the pump proportional to the current signal. For this purpose, enter any two points P1 (I1, F1) and P2 (I2, F2) (F1 is the stroke rate at which the pump is to operate at current I1, F2 is the stroke rate at which the pump is to operate at current I2...); this defines a straight line and thus the behaviour is specified:

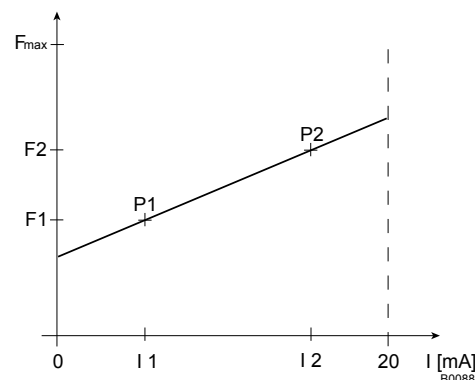

Fig. 21: Rate(frequency)-Current Diagram for Linear control



Plot a diagram similar to the one above - with values for (I_1, F_1) and (I_2, F_2) - so that you can set the pump as desired!

Fault processing

Under the menu option 'Alarm message' (fault) you can activate a fault processing sequence for the 'Curve' processing type. For current signals below 3.8 mA, a fault message appears and the pump stops.

Lower sideband

Using this processing type, you can control a metering pump using the current signal as shown in the diagram below.

The "Lower sideband" symbol appears in the LCD display. Below I_1 , the pump works at a rate of F_1 - above I_2 it stops. Between I_1 and I_2 the stroke rate varies between F_1 and F_2 in proportion to the signal current.

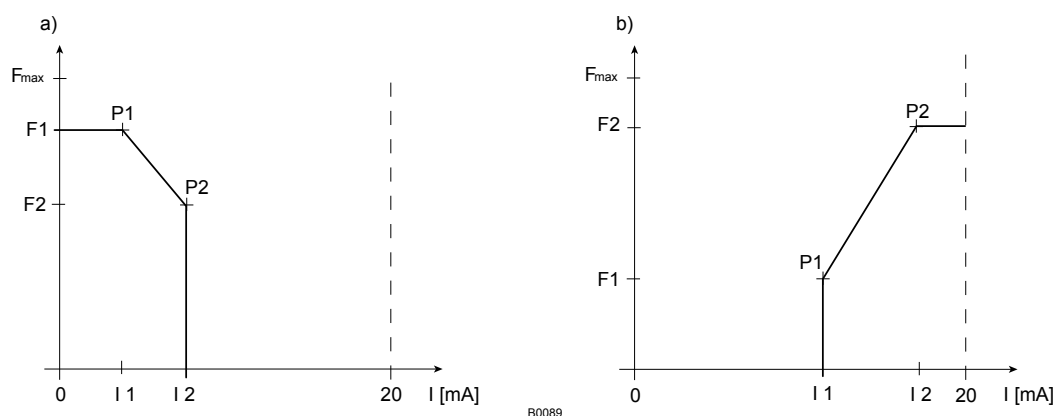

Fig. 22: Frequency-current diagram for a) Lower sideband, b) Upper sideband

Upper sideband

Using this processing type, you can control a metering pump using the current signal as shown in the diagram above.

The "Upper sideband" symbol appears in the LCD display. Below I_1 , the pump is stationary - above I_2 the pump works at rate F_2 . Between I_1 and I_2 the stroke rate varies between F_1 and F_2 in proportion to the signal current.

10.6 Programmable function settings ("Settings" menu)

Setting menus are available in all operating modes in the menu "SETTINGS" for the following programmable functions:

- Auxiliary frequency (menu 'AUX')
- Flow (menu 'FLOW') (only available if a dosing monitor is connected)
- Calibrate (menu 'CALIBRATE')
- Metering (menu 'METERING')
- Relay (menu 'RELAY') (only available if a relay is fitted)
- System (menu 'SYSTEM')

10.6.1 Settings for the "Auxiliary frequency" function (AUX menu)

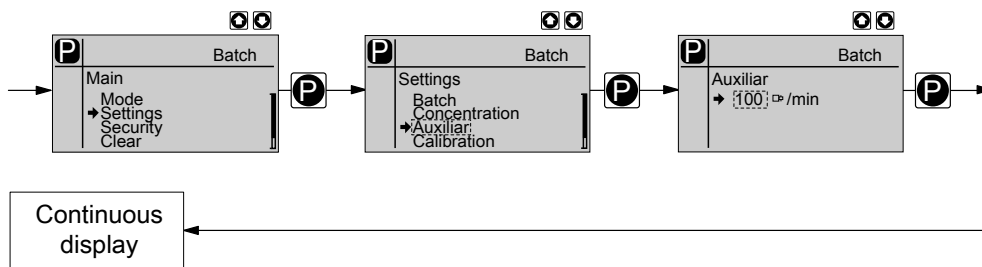

The programmable function "Auxiliary rate" facilitates the switch-over to an auxiliary stroke rate, which can be fixed in the 'AUX' menu. It can be activated via the "External control" terminal. If the auxiliary rate applies, then the identifier "Aux" appears in the LCD display.

This auxiliary rate has priority over the stroke rate, which is specified by the currently selected operating mode - see also the chapter "Function description" - "Hierarchy of operating modes".

10.6.2 Settings for the "Flow" function (FLOW menu)

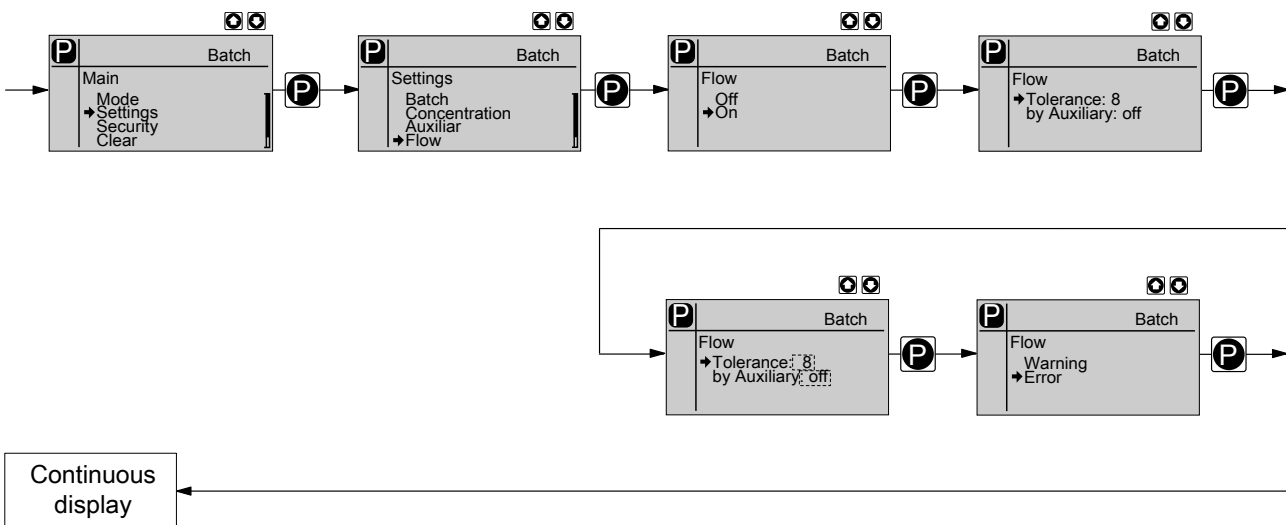

The menu 'FLOW' only appears if a dosing monitor is connected to the "Dosing monitor" jack. The dosing monitor records the individual pressure surges of the pump at the discharge connector during pulsed metering ('Metering' 'fast', menu 'METERING') and immediately reports it back to the pump. In the event that this feed-

back message remains missing in a sequence as often as set in the menu 'FLOW' under 'Tolerance' (due to a failure or too low a metering level), then this function stops the pump. The last menu option provides the choice, of whether this case should lead to a 'Fault' or a 'Warning'.

The function 'Flow' can be deactivated for the 'AUX' operating mode (auxiliary rate).

10.6.3 Settings for the "Calibrate" function (CALIBRATE menu)

The pump can also be operated in the calibrated state. In this case, the corresponding continuous displays then indicate the metering volume or the capacity directly.



Accuracy of the calibration

The calibration will not be accurate, if these conditions are not adhered to:

- do not allow the stroke length to fall below 10 %
- The pump should execute at least 100 strokes.

Calibrate

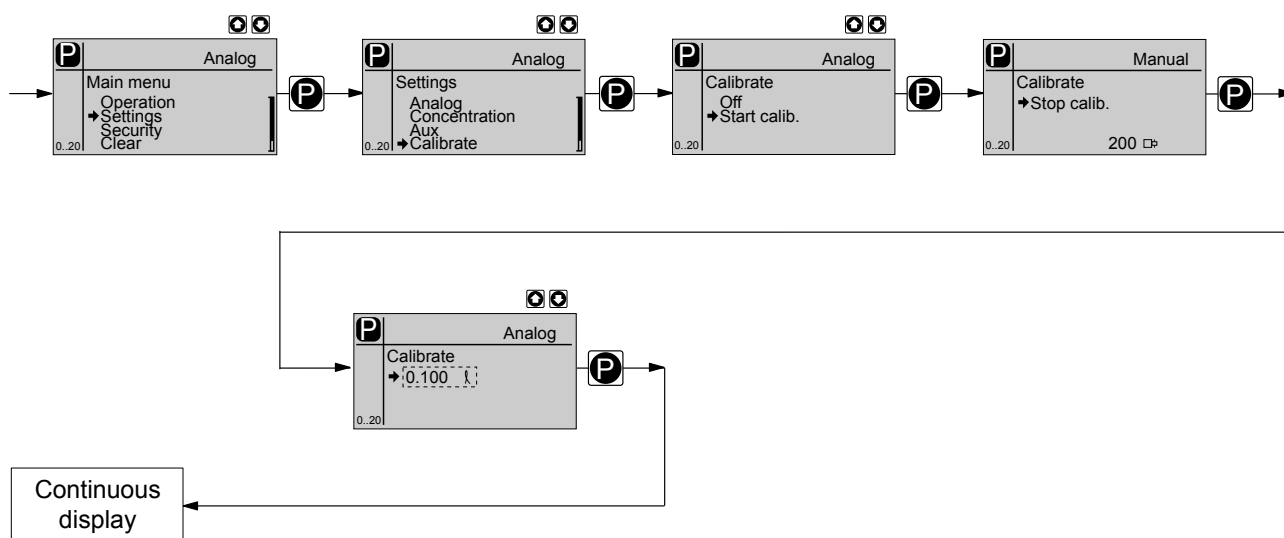

WARNING!

If the feed chemical is dangerous, take appropriate safety precautions when executing the following calibration instructions. Observe the safety data sheet for the feed chemical!



Scales may be better for measuring the metering volume than the measuring cylinder suggested below. This depends on the metering quantities, which must be measured.

1. ▶ Lead the suction hose into a measuring cylinder containing the feed chemical - the discharge hose must be installed in a permanent manner (operating pressure, ...!).
2. ▶ Prime using the feed chemical (simultaneously press the two *[arrow keys]*), should the suction hose be empty.
3. ▶ Record the level in the measuring cylinder.
4. ▶ Using the *[j]* key scroll through the continuous display and check whether litres or gallons are selected.
5. ▶ If the incorrect volume units are selected, select the 'SYSTEM' menu and then the 'UNITS' sub-menu.
6. ▶ Using the *[arrow keys]*, select the correct units and confirm by pressing the *[P]* key.
7. ▶ Select the 'CALIBRATE' menu and then use the *[P]* key to change to the first menu option.
8. ▶ Use the *[DOWN]* key to select 'Start calib.'.
9. ▶ To start the calibration, press the *[P]* key: The next menu option, 'Stop calib.' appears, the pump starts to pump and indicates the stroke rate (the pump works at the stroke rate, which is set under 'MANUAL').
10. ▶ After a reasonable number of strokes (e.g. 100), stop the pump by pressing the *[P]* key.
11. ▶ Determine the required metering volume (difference initial volume - residual volume).
12. ▶ Enter this volume in the menu option which appears and then press the key *[P]* - the pump changes to continuous display.
 - ⇒ The pump is calibrated.

The corresponding continuous displays indicate the calibrated values.

10.6.4 Settings for the "Metering" function (DOSING menu)

10.6.4.1 Settings in the sub-menu "Settings" (metering)

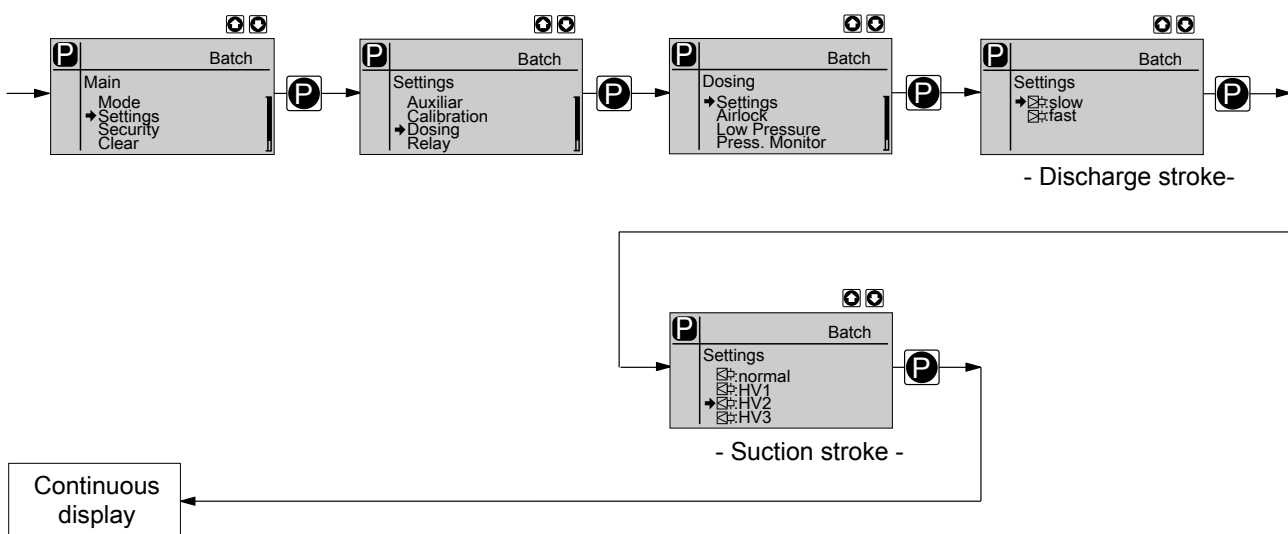

In the sub-menu 'Settings' (metering), you can precisely match the pump metering flow over time against the requirements of the particular application.

Discharge stroke

Hence the user can, dependent on requirements, set a fast discharge stroke ('Metering' - 'fast') for pulsed metering e.g. for quick clocked filling processes (a) or a slow discharge stroke ('Metering' - 'slow') for quasi-continuous metering, e.g. for processes requiring good mixing (b).

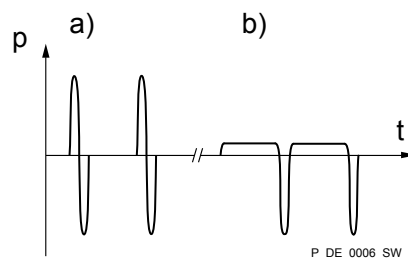

Fig. 23



- During quasi-continuous metering for high accuracy set as large as possible a stroke length.
- The slowing of the discharge stroke only becomes noticeable at lower stroke rates.
- At maximum stroke rate, 'slow' is identical to 'fast'!
- Slowing of the suction stroke leads to a lower capacity.

Suction stroke

In both metering modes it is possible, to selectively also slow the suction stroke. For the case of volatile feed chemicals, the slow suction stroke prevents cavitation and consequently increases metering precision (b) and c). In this way, it is possible to prevent the main cause for imprecise metering with high viscosity feed chemicals, namely the incomplete filling of the liquid end.

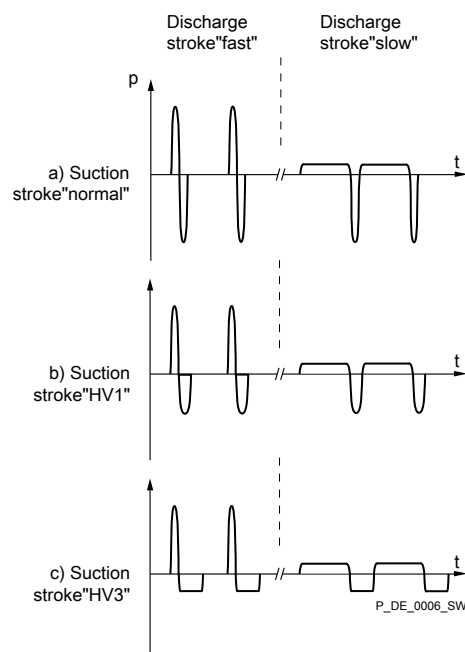

Fig. 24: Pulsed and quasi-continuous Mode with:

- a) normal suction stroke
- b) slightly slowed suction stroke
- c) maximally slowed suction stroke

The metering behaviour of the pump can be matched to the viscosity of the feed chemical.

Viscosity in mPa	"Dosing" setting	Suction stroke slowing	Max. stroke rate	Remarks
0...50	"normal"	none	100	
50...200	"HV1"	slight	75	for valves with springs
200...500	"HV2"	medium	50	for valves with springs
500...1000	"HV3"	Maximum	25	for valves with springs

The viscosities were measured using silicone oil (Newtonian liquids) with a 0.5 m suction line.

For the adjustment for slowing the suction stroke dependent upon the feed chemical viscosity - see the "Adjustment" chapter.

10.6.5 Settings for the "Relay" function (RELAY menu)

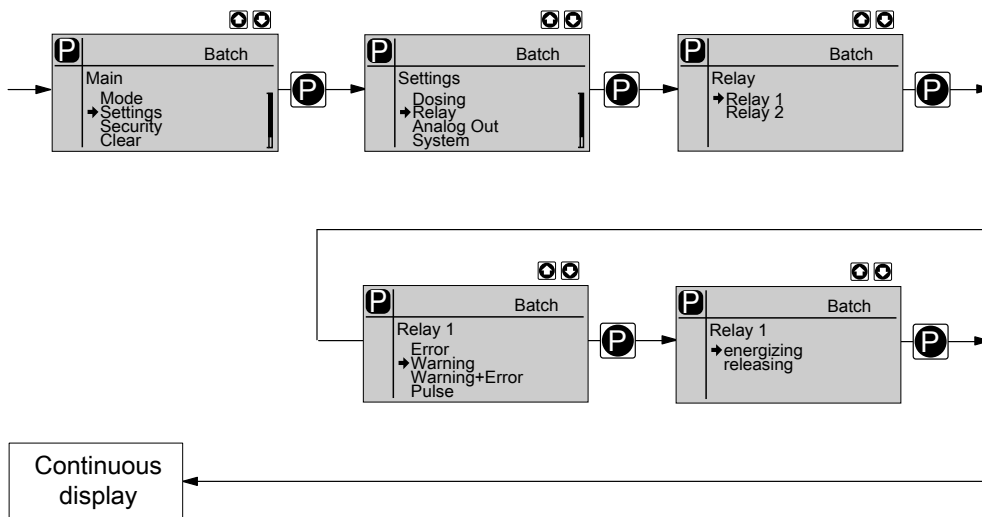

Using the "Relay" programmable function, you can match the pump relays to your requirements.

You can reprogram the relays using the "Relay" function in an almost limited way. Exception: The two 8 A fault indicating relays (under identity code: 1 and 2) and the 8 A cut-off relays (under identity code: 6 and 7) can only be reprogrammed from 'NO' to 'NC' and vice versa.

Allocations for the relay combinations

Identity code specification	Relay type	"Relay 1"	"Relay 2"
		(Mechanical relay)	Semiconductor relay)
4 + 5	Fault indicating relay and pacing relay	Fault indicating relay	Pacing relay
8 + 9	Cut-off relay and pacing relay	Cut-off relay	Pacing relay
A + B	Cut-off relay and warning relay	Cut-off relay	Warning relay

You can set whether the respective relay is to switch due to a triggering event from the timer, upon a warning alert, a fault alert or a pump stroke:

Selectable behaviour types

Setting in the 'Relay' menu	Effect
Warning	The relay switches upon a warning alert (yellow LED*).
Error	The relay switches upon a fault alert (red LED*).
Warning + fault	The relay switches upon a warning alert (yellow LED*) or a fault alert (red LED*).
Pacing relay	The relay switches every stroke.
Option	The relay has the option of which module was plugged in (e.g. timer).
Warn. + Fault + Stop	The relay switches upon a warning alert (yellow LED*) or a fault alert (red LED*) or a stop (key 'STOP/START' or pause).

* see "Troubleshooting" chapter

You can also indicate how the respective relay should behave as soon as it switches. You can change this via the setting 'NO' / 'NC.'



The setting option for the "Relay" function only exists if a relay is present.

The following table summarises once more the behaviour of the deliverable relay types according to the identity code in the as-delivered condition:

Relay type behaviour according to identity code

Relay type	System response
Warning indicating relay	... switches upon a warning alert (yellow LED*).
Fault indicating relay	... switches upon a warning alert (yellow LED*) and / or a fault alert (red LED*).
Cut-off relay	... switches upon a fault alert (red LED*).
Pacing relay	... switches with every pump stroke.

* see "Troubleshooting" chapter

10.6.6 Settings for the "Analog output" function (ANALOG OUTPUT menu)

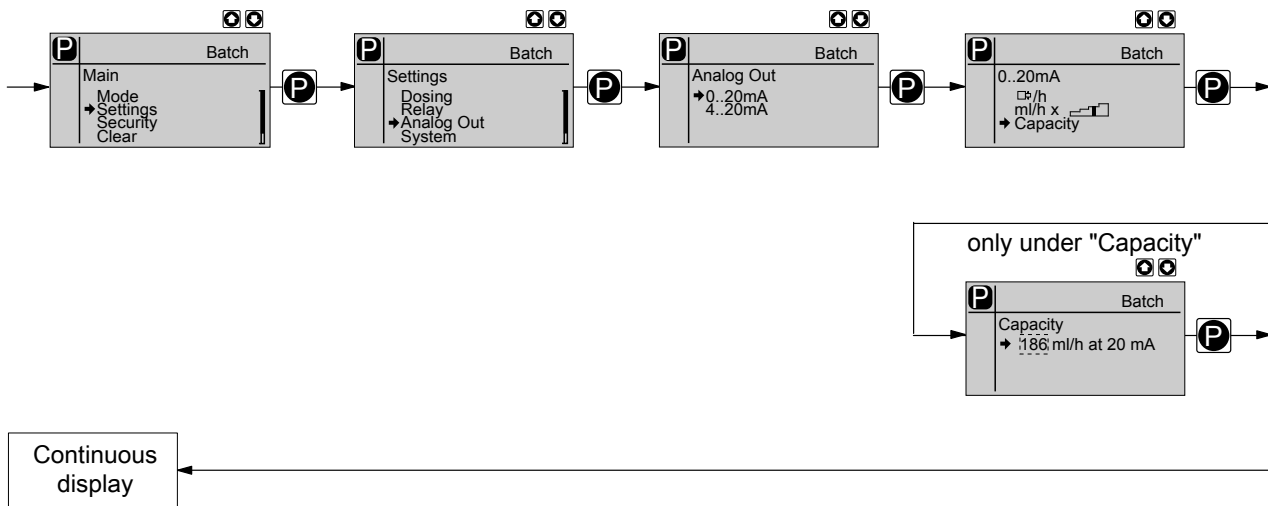

Using the "Analog output" programmable function, you can match the pump current output signal to your requirements.

The signal I of the current output signal one of the three following variables:

- Strokes /h
- mL / h x stroke length (= current, calculated capacity)
- Performance (= capacity, value adjustable at 20 mA)

In the "Stop" or "Pause" states (either because of a fault or operation) or "Pause" the current output emits a current of 4 mA.

The signal for the current, calculated capacity "mL / h *" is calculated by the pump according to the following formula (here for the range 4-20 mA):

$$I(4 \dots 20) = 16 \times (f/f_{max}) \times (L/100) + 4$$

with

- I - Output current in mA
- f - Stroke rate in strokes/min
- L - Stroke length in %
- fmax - Maximum stroke rate in strokes/min

In the 'Contact' and 'Batch' operating modes, f is the stroke rate which is set in the "Stroke rate" continuous display.

10.6.7 Settings in the "System" menu" (SYSTEM menu)

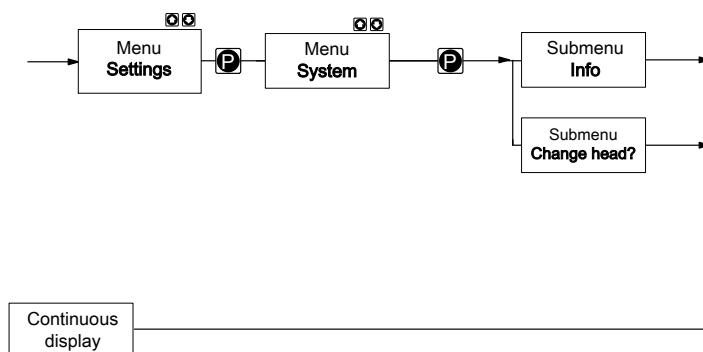

The "System" menu branches into the following sub-menus:

- Info
- Change head?

10.6.7.1 "Info" sub-menu

In the "Info" sub-menu you can read off the following identification numbers:

- Identity code ID
- Serial number SN
- Software control SW
- Hardware control HW
- Software drive AS
- Hardware drive AH
- Name module-option (e.g. proTIME)
- Software option OS
- Hardware option OH

10.6.7.2 Sub-menu "Change head?"



CAUTION!

- Should a different liquid end size be fitted, then the pump must be reprogrammed in the sub-menu 'Change head?'.
.
- For demonstration purposes or if operating without feed chemical, reprogram the pump to 'Without head'.

10.7 Set code (SECURITY menu)

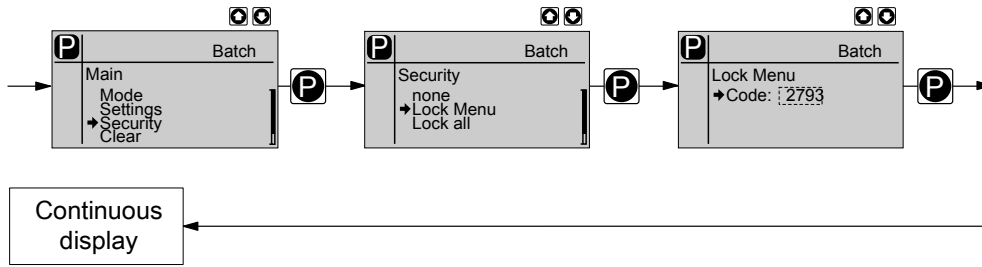

In the 'SECURITY' menu, you can enter whether you want to block sections of the adjustment options.

In the first menu option, you can either set 'None' or 'Lock menu' or 'Lock all' (both locks use the same code.):

- Select 'None', to clear a security lock.
- Select 'Lock menu' to lock the adjustment mode (point ① in the overview "Operating/setting diagram", in the appendix). In the next menu option, enter the number you want to use as the code.
- Select 'Lock all' to lock the adjustment option for the directly adjustable variables in the continuous displays and to lock the stroke length (point ② in the overview "Operating/setting diagram", in the appendix), in addition to the adjustment mode. In the next menu option, enter the number you want to use as the code.

If a lock is set, a padlock appears in the continuous display.

If you have set 'Lock all', a padlock will appear after 1 minute in the top left corner and the specified areas are locked, if no key has been pressed in the meantime.

If you have set 'Lock menu', the operating menu will be locked after 1 minute, if no key has been pressed in the meantime.

Test

To test whether the menu is locked, press the [P] key for 2 s.

If you try to change into a locked area, a key appears in the LCD display and the padlock flashes.

Overriding the lock

To override the lock, enter the code using the [arrow keys].

Changing the stroke length variable

In the stroke adjustment dial has been turned, the padlock flashes, the pump stops and a fault alert and key appear. If you enter the code, the pump continues metering and the fault alert clears.

10.8 Delete total number of strokes or total litres (CLEAR menu)

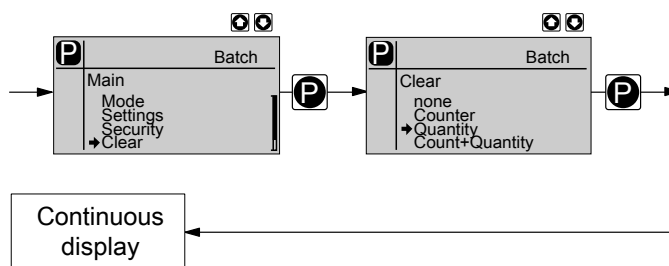

In the *'DELETE'* menu, you can either delete the stored total number of strokes or the total litres or both together (= reset to "0"):

- *'None'*
- *'Counter'* (total number of strokes)
- *'Quantity'* (total litres)
- *'all'* (both)

To do this quit the menu by quickly pressing the key *[P]* key.

The variables have increased since commissioning of the pump, the last calibration or the last deletion.

10.9 Set language (LANGUAGE menu)

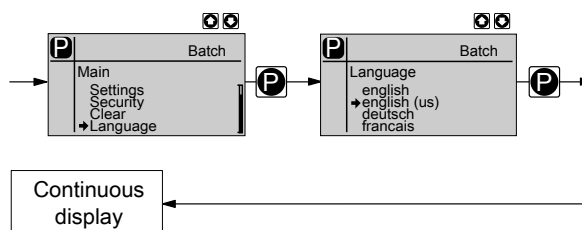

In the *'LANGUAGE'* menu, you can select the desired operating language.

The selection *'English (US)'* also changes the decimal comma to a decimal point in the displays.

11 Operation



WARNING!

Warning of crushing of the fingers

The moving parts in the current can crush fingers.

- The protective bush on the liquid end must always be closed when the pump is ready for operation.



CAUTION!

If the vent screw is open, feed chemical escapes.

- As necessary, implement suitable protective measures.
- Adhere to the safety data sheet for the feed chemical.



WARNING!

Danger of electric shock

Incompletely installed electrical options can allow moisture into the inside of the housing.

- Knock-out openings in the pump housing must be equipped with matching modules or be sealed in a leak-tight manner.



WARNING!

Danger of electric shock

A mains voltage may exist inside the pump housing.

- If the pump housing has been damaged, you must disconnect it from the mains immediately. It may only be returned to service after an authorised repair.

This chapter describes all the operating options available to you if the pump is displaying a continuous display - the display does not contain the symbol for the [P] key.



- *For supplementary information, see the overviews "Control elements and key functions" in the chapter "Device overview and control elements" and "Operating/setting diagram" in the appendix.*
- *Also take note of the overview "Continuous displays" in the appendix. It shows which continuous displays are available in which operating mode and which variables are directly changeable in the relevant continuous display.*

11.1 Manual

Personnel: Instructed personnel

Adjusting the stroke length



The pump may demonstrate unexpected behaviour during operation.

- *Do not set the stroke length adjustment knob to more than 100 %.*

The stroke length is adjusted by the stroke length adjustment knob within a range of 0 ... 100 %. A stroke length of between 4 ... 100 %) is recommended to achieve the specified reproducibility.

The following image shows the settings for two stroke length values on the fine stroke length adjustment knob and the use of the locking lever.

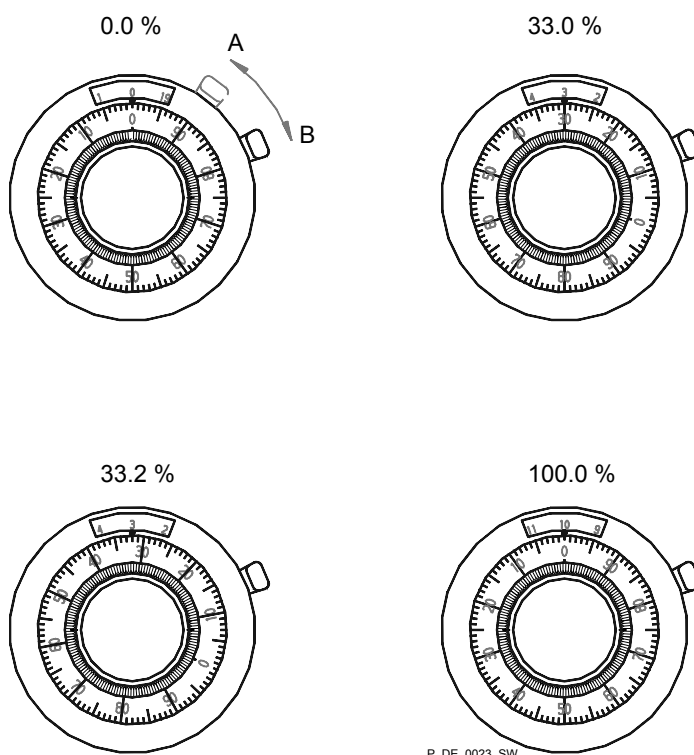

Fig. 25: Adjustment examples for stroke length values: 0.00 %, 33.0 %, 33.2 % and 100.0 %. Locking lever in position A: stroke length adjustment knob free; locking lever in position B: Stroke length adjustment knob locked.

100 % corresponds to 5 mm stroke length corresponds to 10 rotations

Calculation example

A stroke length of 2 mm is to be set.

$$\text{i.e.: } 2 \text{ mm} \times (100\% / 5 \text{ mm}) = 2 \text{ mm} \times (20\% / 1 \text{ mm}) = \mathbf{40 \%}$$

The following operating options are available via the keys - see the next figure:

Stop/start pump

Stop the pump: Press the *[STOP/START]* key.

Start the pump: press the *[STOP/START]* key again.

Start batch

In *'Batch'* operating mode: briefly press key *[P]*.

Changing to adjustment mode

If the *[P]* key is pressed for 2 seconds in a continuous display, the delta® changes to adjustment mode - see chapter "Adjustment".

If an access code was set in the "Security" menu for *'Lock menu'*, then after pressing the *[P]* key the access code must first be entered.

Checking adjustable variables

After every press of the *[i]* key, a different continuous display is shown. The number of continuous displays depends on the identity code, the selected operating mode and the connected additional devices.

Changing directly changeable variables

To change a variable, see below, directly in the corresponding continuous display, press and hold one of the *[arrow keys]* (approx. 1/2 s) until the identifier "Double arrow" appears and the variable is flanked by two flashing lines. The delay has been programmed in to prevent variables from being unintentionally changed.

If an access code was set in the "Security" menu for *'Lock all'*, then after pressing the *[P]* key the access code must first be entered.

The directly changeable variables are in detail:

stroke rate

In operating modes *'Manual'*, *'Contact'* and *'Batch'*:

You can change the stroke rate in the "Stroke rate" continuous display.



To change a precisely previously set feed rate (possibly specified in litres), there is an option of changing it via the stroke rate. As the stroke rate is digitally processed, there is no tolerance.

Changing using the stroke length interferes with the mechanical tolerance.

Capacity

In *'Manual'* operating mode:

You can change the capacity in the "Capacity" continuous display.

Factor

The factor is the number of strokes which are triggered upon an external pulse or by pressing key *[P]* (only in *'Batch'* operating mode).

Priming

Simultaneous pressing of the two *[arrow keys]* triggers the "Priming" function (in the "Stroke rate" continuous display).

Fault acknowledgement

Fault displays are acknowledged by brief pressing of the *[P]* key.

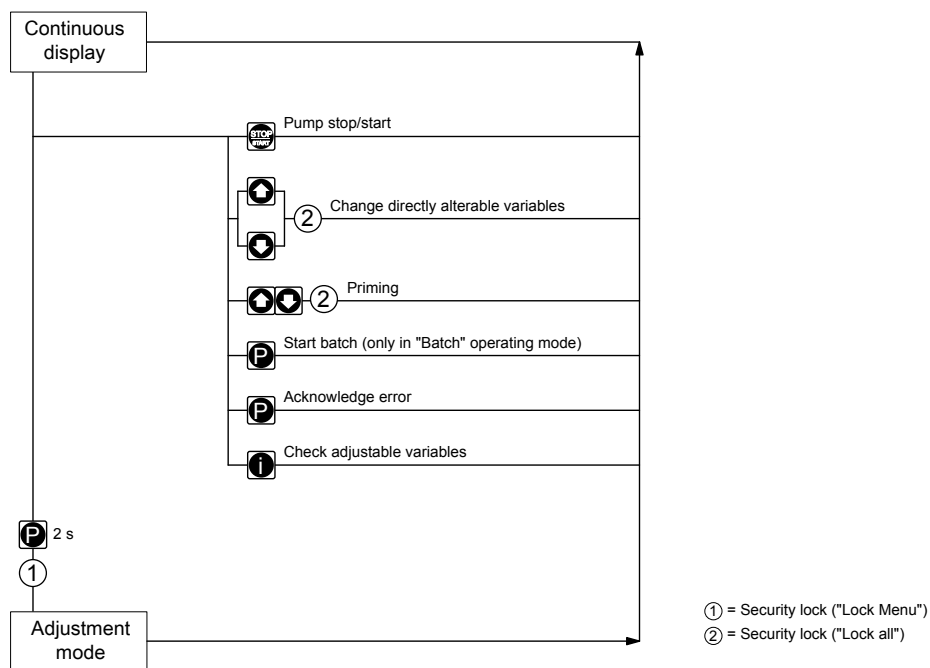

Fig. 26: Operating options with a locked operating menu

11.2 Remote operation

There is an option to control the pump remotely via a signal cable - refer to your system documentation and to the "Electrical Installation" chapter.

12 Maintenance



WARNING!

It is mandatory that you read the safety information and specifications in the "Storage, Transport and Unpacking" chapter prior to shipping the pump.



CAUTION!

Warning of feed chemical spraying around

Feed chemical can spray out of the hydraulic components if they are manipulated or opened due to pressure in the liquid end and adjacent parts of the system.

- Disconnect the pump from the mains power supply and ensure that it cannot be switched on again by unauthorised persons.
- Depressurise the system before commencing any work on hydraulic parts.

Standard liquid ends:

Interval	Maintenance work	Personnel
Quarterly*	<ul style="list-style-type: none"> ■ Check the condition of the sealing sleeves - see the "Overhaul" chapter. ■ Check that the dosing lines are fixed firmly to the liquid end. ■ Check that the suction valve and discharge valve are tight. ■ Check the tightness of the entire liquid end - particularly around the leakage hole, see the following figure. ■ Check that the flow is correct: Allow the pump to prime briefly - quickly press both <i>[arrow keys]</i> simultaneously. ■ Check that the electrical connections are intact and check the pump housing. ■ Check that the dosing head screws are tight 	Technical personnel

* under normal loading (approx. 30 % of continuous operation)

Under heavy loading (e.g. continuous operation): Shorter intervals.

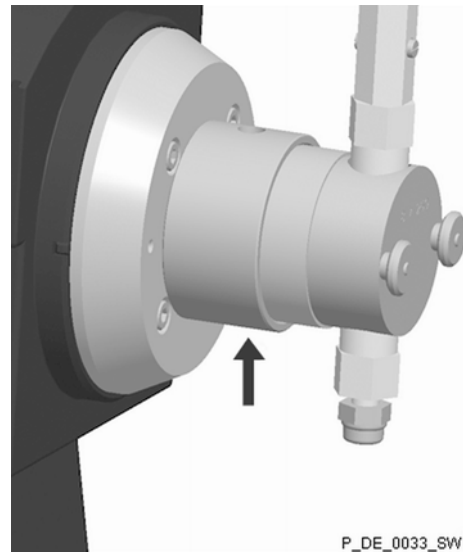

Fig. 27: Leakage hole

13 Overhaul

Safety information



WARNING!

Danger of an electric shock

Unauthorised repairs inside the pump can result in an electric shock.

For this reason repairs inside the pump may only be performed by a ProMinent subsidiary or representative, in particular the following:

- Replacement of damaged mains connection lines
- Replacement of fuses
- Replacement of electronic control



WARNING!

It is mandatory that you read the safety information and specifications in the "Storage, Transport and Unpacking" chapter prior to shipping the pump.



WARNING!

Contact with the feed chemical

Parts that come into contact with the feed chemical are uncovered and handled during overhaul work.

- Protect yourself from the feed chemical should it be hazardous. Read the safety data sheet on the feed chemical.



CAUTION!

Warning of feed chemical spraying around

Feed chemical can spray out of the hydraulic components if they are manipulated or opened due to pressure in the liquid end and adjacent parts of the system.

- Disconnect the pump from the mains power supply and ensure that it cannot be switched on again by unauthorised persons.
- Depressurise the system before commencing any work on hydraulic parts.

13.1 Cleaning valves



- *The exploded views in the Appendix should be referred to when working on the unit.*
- *Clean all parts with a suitable cleaning agent (without (without grinding or scouring particles)).*

Take off the liquid end from the drive



The liquid end may only be mounted later, after the valves have been screwed in. Otherwise the connecting point between the liquid end and valve may subsequently become untight. To do this, the liquid end must first be removed from the drive.

Personnel: ■ Technical personnel

➔ Take off the liquid end - ↪ Chapter 13.2 'Replacing liquid end parts' on page 63

Cleaning a back pressure valve

- ➔ Unscrew the back pressure valve in a counterclockwise direction from the discharge valve.

**WARNING!****Danger of eye injuries**

The back pressure valve contains a pretensioned compression spring.

- Wear safety glasses when dismantling.



Dismantle the valve inserts of the valves one after each other, so that you do not confuse the parts.

- ➔ Guide a thin flat pin or similar into the smaller hole of the discharge connector and push the valve inserts out of it.
- ➔ Inspect all parts for damage before assembling.
- ➔ After cleaning the valve, first screw it on finger-tight.
- ➔ Tighten the valve according to the following table.

Material version	Tightening instruction
TT_	approx. 30 ... 45°
SS_	approx. 45° or approx. 8 Nm

Cleaning a discharge valve



- *Discharge and suction valves differ from each other! Only take them apart one after each other, so that you do not confuse the components!*
- *Only use new components which fit your valve - both in terms of shape and chemical resistance!*
- *Readjust the pump after replacing a valve!*

- ➔ Inspect all parts for damage before assembling.
- ➔ After cleaning the valve, first screw it on finger-tight.
- ➔ Tighten the valve according to the following table.

Material version	Tightening instruction
TT_	approx. 30 ... 45°
SS_	approx. 45° or approx. 9 ... 10 Nm



With new seals tighten the valves approx. 90 ... 120°.

Cleaning a suction valve

A suction valve is constructed in almost the same way as a discharge valve.

Please note, however, that:

- the two valve inserts are identical here
- there are a few flat seals in the dosing head and valves, which may possibly have to be renewed.
- The flow direction of the suction connector is the opposite of that of the discharge connector.

1. ➤ Inspect all parts for damage before assembling.
2. ➤ After cleaning the valve, first screw it on finger-tight.
3. ➤ Tighten the valve according to the following table.

Material version	Tightening instruction
TT_	approx. 30 ... 45°
SS_	approx. 45° or approx. 9 ... 10 Nm



With new seals tighten the valves approx. 90 ... 120°.

13.2 Replacing liquid end parts

Personnel: ■ Technical personnel

Dismantling the dosing head

- If necessary, use protective equipment.
 - Disconnect the pump from the mains power supply and secure to prevent switching on again.
 - Depressurise the system.
1. ➤ Empty the liquid end: Unscrew the back pressure valve from the discharge valve starting slowly (to release the pressure). Place the liquid end on its head and allow the feed chemical to run out; flush out with a suitable medium; flush the liquid end thoroughly when using hazardous feed chemicals!

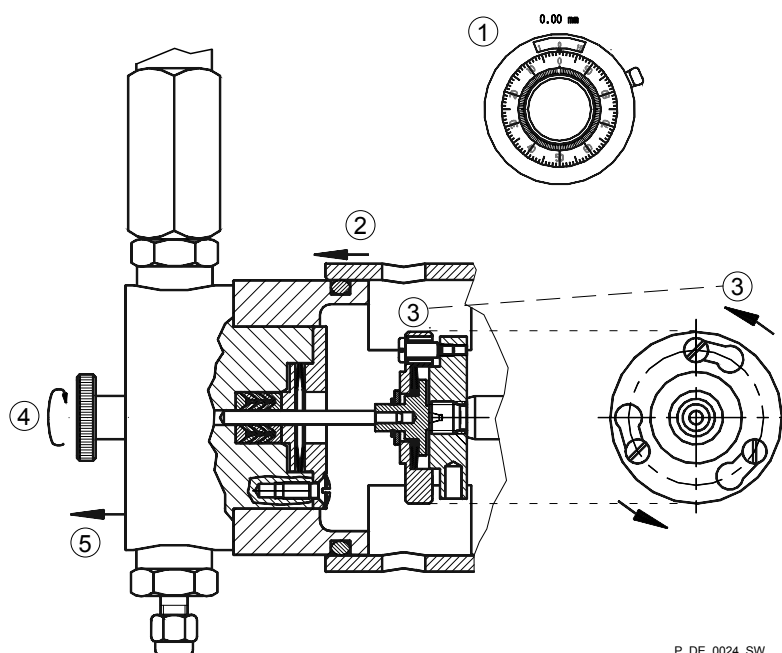

P_DE_0024_SW

Fig. 28

2. ➤ ① Turn the stroke adjustment knob until it can go no further with 0 % stroke length if the pump is running (the drive axle is then blocked).
3. ➤ Switch off the pump.
4. ➤ Unscrew the hydraulic connectors on the discharge and suction side.



The following handling instructions relate to a pump, which with the liquid end points away in one direction.

5. ➤ ② Push the protective bush (10) over the piston coupling in a forwards direction.
6. ➤ Insert a thin pin (screwdriver, Alley key) into the hole in the grooved coupling disc (7).
7. ➤ ③ Uncouple the piston by pressing it against the pump and turning the coupling disc (7) to the left (bayonet connection).
8. ➤ ④ Remove the forward knurled screws (1) from the dosing head.

9. ➔ ⑤ Take the dosing head (2) with piston (1) off from the pump.

Fitting of packing and piston

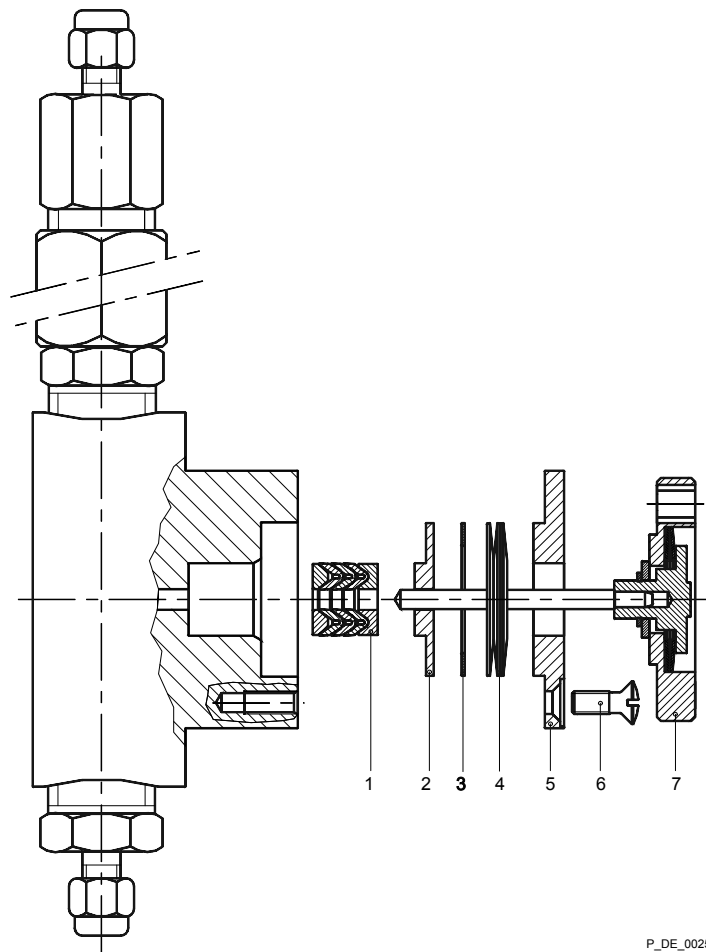

P_DE_0025_SW

Fig. 29

- 1 V-sleeve set
- 2 Pressure plate
- 3 Shim
- 4 Disc springs
- 5 Friction washer
- 6 Screws
- 7 Piston

TTT, TTG:

SST, SSG:

Type 100150

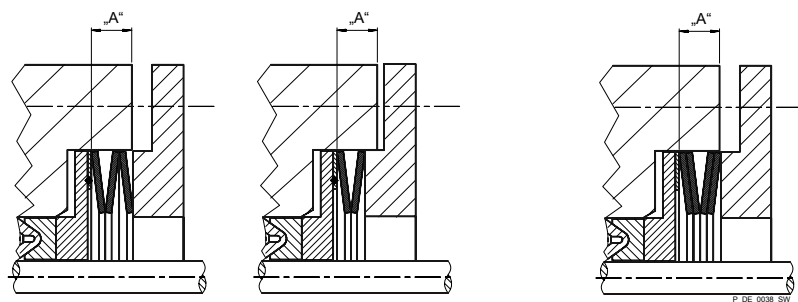

P_DE_0038_SW

Fig. 30: Arrangement and dimension "A" for the disc springs

- 1. ➔ Insert the V sleeve set (1) with forward opening in the dosing head.
- 2. ➔ Position the pressure plate (2).

3. → Check dimension "A", if necessary insert the shim (3).

Dimension "A" - in mm

Type	A
100150	3.0
100600	3.3
101500	3.3
600150	4.0
400600	3.8
201500	3.3

4. →



Precisely observe the arrangement of the disc springs.

Insert the disc springs (4) precisely as shown.

5. → Position the friction washer (5).
 6. → Screw the screws (6) in by hand - do not overtighten!
 7. → Carefully insert the piston (7).



If the liquid end is to be stored, this is the correct condition.

8. → Screw the screws (6) on to the friction washer (5) with the piston (7) inserted. Tighten in a diagonal pattern until the stop is reached.

⇒ Now the liquid end is ready for use.



The piston should not be pulled out of the dosing head once the friction washer is tightened.

Should this occur however, the screws (5) must first be loosened before the piston can be pushed into the dosing head.

Fitted dosing head

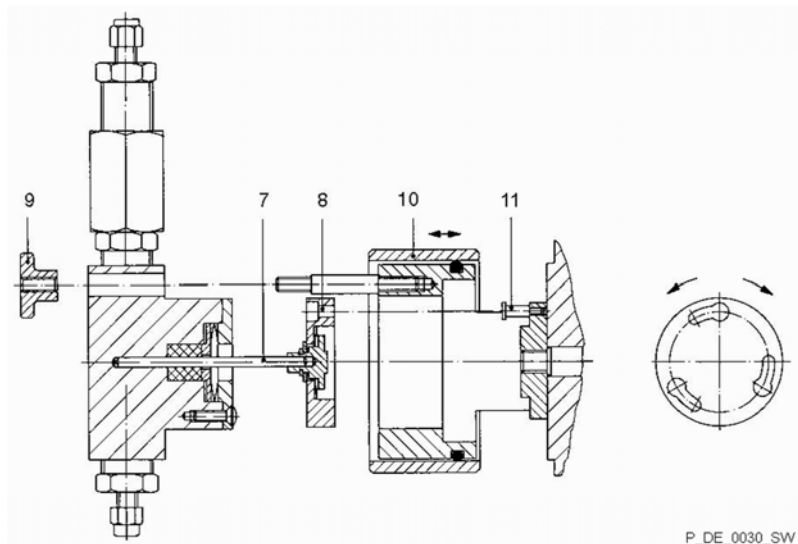

P_DE_0030_SW

Fig. 31

- 7 Piston
- 8 Coupling disc
- 9 Knurled screws
- 10 Protective bush
- 11 Coupling screws

1. Carefully pull the piston (7) out far enough, so that the coupling disc (8) with its longitudinal holes can project over the heads of the coupling screws (11).
2. Push on the dosing head.
3. Tighten the knurled screws (9).
⇒ The liquid end is now secured.



Piston fracture risk

Do not tilt the piston in the step described here.

4. Snap the coupling disc (8) on to the coupling screws (11) by pressing against the pump and turning to the right over the inserted pin (bayonet connection).
5. Check the pump operation.
6. Push the protective bush (10) backwards over the piston coupling.

14 Troubleshooting

Safety information



WARNING!

Warning of hazardous or unknown feed chemical

Should a hazardous or unknown feed chemical be used, it may escape from the hydraulic components when working on the pump.

- Take appropriate protective measures before working on the pump (protective eyewear, protective gloves, ...). Read the safety data sheet on the feed chemical.
- Drain and flush the liquid end before working on the pump.



CAUTION!

Warning of feed chemical spraying around

Feed chemical can spray out of the hydraulic components if they are manipulated or opened due to pressure in the liquid end and adjacent parts of the system.

- Disconnect the pump from the mains power supply and ensure that it cannot be switched on again by unauthorised persons.
- Depressurise the system before commencing any work on hydraulic parts.

14.1 Faults without a fault alert

Fault description	Cause	Remedy	Personnel
Pump does not prime in spite of full stroke motion and bleeding	Minor crystalline deposits on the ball seat due to the valves drying out	Take suction tube out of the storage container and thoroughly flush out the liquid end	Technical personnel
	Major crystalline deposits on the ball seat due to the valves drying out	Dismantle the valves and clean them - refer to the "Overhaul" chapter.	Technical personnel
Liquid is dripping between the dosing head housing from the securing flange.	Carbon grit from the sleeve packing has been deposited on the piston.	Allow the metering pump to operate briefly using dichloromethane or acetone, so that the impurities are cleared and the piston seal, seals again.	
	The sleeve packaging is worn.	Replace the sleeve packaging - refer to the "Overhaul" chapter.	Technical personnel
Green LED indicator (operating indicator) does not light up	The wrong mains voltage or no mains voltage is connected	Connect the pump correctly to the specified mains voltage - according to the specification on the name-plate.	Electrician

14.2 Fault alerts

Fault description	Cause	Remedy	Personnel
The red LED indicator illuminates, the "Level" symbol  flashes in the LCD display, the "Fault" and "Stop" symbols are also displayed and the pump stops.	The liquid level in the storage tank has reached "liquid level low 2nd stage".	Fill the storage tank	Technical personnel
The red LED indicator illuminates, the symbol "i < 4 mA"  flashes in the LCD display, the "Fault" and "Stop" symbols are also displayed and the pump stops.	The pump is in "Analog" operating mode, a fault behaviour has been programmed in the ANALOG menu and the control current has fallen below 4 mA.	Clear the cause of the low control current or switch the programming of the fault behaviour to "OFF" - see chapter "Settings for 'Analog' operating mode".	Technical personnel
The red LED indicator illuminates, the symbol "i > 23 mA"  flashes in the LCD display, the "Fault" and "Stop" symbols are also displayed and the pump stops.	The pump is in "Analog" operating mode, a fault behaviour has been programmed in the ANALOG menu and the control current has risen above 23 mA.	Clear the cause of the high control current or switch the programming of the fault behaviour to "OFF" - see chapter "Settings for 'Analog' operating mode".	Technical personnel
The red LED indicator illuminates, the symbols "m" and "External"  flashes in the LCD display, the "Fault" and "Stop" symbols are also displayed and the pump stops.	The stroke memory has overflowed.	Rectify the cause, then press the <i>[P]</i> key (think of the consequences for the process!).	Technical personnel
The red LED indicator illuminates, the "Temperature" symbol  flashes in the LCD display, the "Fault" and "Stop" symbols are also displayed and the pump stops.	The pump is overloaded.	Rectify the cause, then press the <i>[P]</i> key (think of the consequences for the process!).	Technical personnel
	The temperature is too high.	Rectify the cause, then press the <i>[P]</i> key (think of the consequences for the process!).	Technical personnel
The red LED indicator illuminates, the "Stroke length adjustment" symbol  flashes in the LCD display, the "Fault" and "Stop" symbols are also displayed and the pump stops.	The stroke adjustment dial was rotated while the menu was locked.	Turn the stroke adjustment dial back or enter the code.	Technical personnel
The red LED indicator illuminates, the "Stroke length adjustment" symbol  flashes in the LCD display, the "Fault" and "Stop" symbols plus the letters "SP" are also displayed and the pump stops.	The stroke adjustment dial was turned over 100 %.	Turn the stroke adjustment dial back.	Instructed personnel

14.3 Fault alerts / warning alerts

At issue here are error alerts, which dependent on the setting in the setting menu are displayed as fault alerts or warning alerts.

Fault description	Cause	Remedy	Personnel
Either the yellow LED indicator illuminates and the "Flow" symbol  flashes in the LCD display, or, together with the red LED indicator, the symbols for "Fault" and "Stop" also appear and the pump stops.	The dosing monitor is not correctly connected.	Connect the dosing monitor correctly and press the <i>[P]</i> key.	Electrician
	The dosing monitor reported too few strokes, more than set in the FLOW menu.	press the <i>[P]</i> key. Investigate and clear the cause	Technical personnel

14.4 Warning Alerts

Fault description	Cause	Remedy	Personnel
The yellow LED indicator illuminates, the "Level" symbol  appears flashing in the LCD display.	The liquid level in the storage tank has reached "liquid level low 1st stage".	Fill the storage tank	Instructed personnel

14.5 All Other Faults

Please contact the responsible ProMinent subsidiary or representative!

15 Decommissioning

Decommissioning



WARNING!

Danger from chemical residues

There is normally chemical residue in the liquid end and on the housing after operation. This chemical residue could be hazardous to people.

- It is mandatory that the safety information relating to the "Storage, transport and unpacking" chapter is read before shipping or transporting the unit.
- Thoroughly clean the liquid end and the housing of chemicals and dirt. Adhere to the safety data sheet for the feed chemical.



WARNING!

Warning of dangerous or unknown feed chemical

Should a dangerous or unknown feed chemical be used: It may escape from the hydraulic components when working on the pump.

- Take appropriate protective measures before working on the pump (e.g. safety glasses, safety gloves, ...). Observe the safety data sheet for the feed chemical.
- Drain and flush the liquid end before working on the pump.



CAUTION!

Warning of feed chemical spraying around

Feed chemical can spray out of the hydraulic components if they are manipulated or opened due to pressure in the liquid end and adjacent parts of the system.

- Disconnect the pump from the mains power supply and ensure that it cannot be switched on again by unauthorised persons.
- Depressurise the system before commencing any work on hydraulic parts.



Danger of damage to the device

Take into account the information in the "Storage, Transport and Unpacking" chapter if the system is decommissioned for a temporary period.

Personnel: ■ Technical personnel

1. ➤ Disconnect the pump from the mains power supply.
2. ➤ Unscrew the back pressure valve from the discharge valve, slowly, to allow the pressure to reduce.
3. ➤ Empty the liquid end by turning the pump upside down and allowing the feed chemical to run out.
4. ➤ Flush the liquid end with a suitable medium; flush the dosing head thoroughly when using hazardous feed chemicals!

Disposal

**CAUTION!****Warning of feed chemical spraying around**

Feed chemical can spray out of the hydraulic components if they are manipulated or opened due to pressure in the liquid end and adjacent parts of the system.

- Disconnect the pump from the mains power supply and ensure that it cannot be switched on again by unauthorised persons.
- Depressurise the system before commencing any work on hydraulic parts.

Personnel: ■ Technical personnel

**CAUTION!****Environmental hazard due to electronic waste**

There are electronic components in the pump, which can have a toxic effect on the environment.

- Separate the electronic components from the remaining parts.
- Note the pertinent regulations currently applicable in your country!

16 Technical data

16.1 Performance data

mikro delta® b operating at 100 strokes/minute and 100 % stroke length

Liquid end type	Minimum pump capacity at maximum back pressure			Piston diameter mm	Stroke rate Strokes/min
	bar	ml/h	µl/stroke		
100150 TT	10	145	24.17	2.5	100
100600 TT	10	580	96.67	5	100
101500 TT	10	1480	246.67	8	100
600150 SS	60	145	24.17	2.5	100
400600 SS	40	580	96.67	5	100
201500 SS	20	1480	246.67	8	100

Liquid end type	Hose connector size outside Ø x inside Ø	Pipe connector size outside Ø	Suction lift*	Priming lift**	Permissible priming pressure suction side	Back pressure valve holding pressure
	mm	mm	m WS	m WS	bar	bar
100150 TT	1.75x1.15	-	6	0.6	5	2.5
100600 TT	1.75x1.15	-	6	2.0	5	2.5
101500 TT	3.2x2.4	-	4	2.0	5	1.5
600150 SS	1.75x1.15	1.58	6	0.6	30	2.5
400600 SS	1.75x1.15	1.58	6	2.0	20	2.5
201500 SS	3.2x2.4	3.18	4	2.0	10	1.5

* - Suction lift with a filled suction line and filled liquid end.

** - Priming lift with clean and moist valves. Feed chemical water at 20 °C. Priming lift at 100 % stroke length, opened vent screw and suction line as described.

16.2 Viscosity

The metering behaviour of the pump can be matched to the viscosity of the feed chemical.

Viscosity in mPa	"Dosing" setting	Suction stroke slowing	Max. stroke rate	Remarks
0...50	"normal"	none	100	
50...200	"HV1"	slight	75	for valves with springs

Viscosity in mPa	"Dosing" setting	Suction stroke slowing	Max. stroke rate	Remarks
200...500	"HV2"	medium	50	for valves with springs
500...1000	"HV3"	Maximum	25	for valves with springs

The viscosities were measured using silicone oil (Newtonian liquids) with a 0.5 m suction line.

For the adjustment for slowing the suction stroke dependent upon the feed chemical viscosity - see the "Adjustment" chapter.

16.3 Material data

Liquid ends

Version	Dosing head	Suction/discharge connector	Valve balls	Valve seats	Piston	Valve seals	Piston seals
TTT	PTFE + carbon	PTFE + carbon	Jewel	Ceramic	Ceramic	PTFE	PTFE, white
TTG	PTFE + carbon	PTFE + carbon	Jewel	Ceramic	Ceramic	PTFE	PTFE + graphite
SST	Stainless steel 1.4571	Stainless steel 1.4571	Jewel	Ceramic	Ceramic	PTFE	PTFE, white
SSG	Stainless steel 1.4571	Stainless steel 1.4571	Jewel	Ceramic	Ceramic	PTFE	PTFE + graphite

Pump

Version	Housing	Hood	Transparent cover	Electronics
All	Polyphenyl ether (PPE with fibre-glass)	Polyphenyl ether (PPE with fibre-glass)	Polycarbonate	Electronic components

16.4 Electrical data

Version: 100 - 230 V ±10 %, 50/60 Hz

Data	Value	Unit
Power rating, approx.	38	W
Nominal current, approx.	0.64 ... 0.42	A
Switch on peak current, (within approx. 50 ms falling)	8 ... 4	A
Fuse	1.6	AT

Fuses must have VDE, UL and CSA approvals. e.g. Series SPT, 1.6 A supplied by Schurter Order no. 0001.2506 according to IEC Publ. 127 - 2/3.

16.5 Temperatures

Pump, compl.

Data	Value	Unit
Storage and transport temperature	-10 ... +50	°C
Ambient temperature in operation (drive and control):	-10 ... +45	°C

Liquid end, long-term*

Data	Value	Unit
Liquid end temperature	-10 ... +45	°C

* long term at max. operating pressure, dependent on ambient and feed chemical temperatures

Liquid end, short-term*

Material version	Value	Unit
TT_	120	°C
SS_	120	°C

* Temp. max., for 15 min at max. 2 bar, dependent on the ambient and feed chemical temperatures

16.6 Climate

Data	Value	Unit
Maximum air humidity *:	95	% rel. humidity

* non-condensing

Exposure in a humid and alternating climate:

FW 24 according to DIN 50016

16.7 Protection class and Safety Requirements

Degree of protection

Protection against contact and humidity:

IP 65 in accordance with IEC 529, EN 60529, DIN VDE 0470 Part 1

Safety requirements

Degree of protection:

1 - mains power connection with protective earth conductor

16.8 Weight

Material version	Weight
	kg
TT_	10
SS_	11

16.9 Sound pressure level

Sound pressure level

Sound pressure level LpA < 70 dB in accordance with EN ISO 20361:2010-10

at maximum stroke length, maximum stroke rate, maximum back pressure (water)

17 Dimensions sheets

Dimensions sheet delta[®], material versions TT and SS

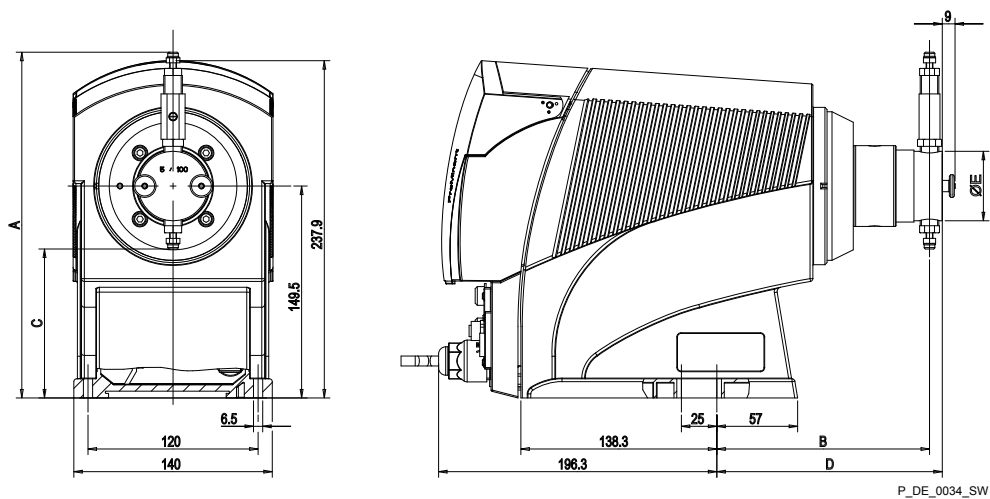

Fig. 32: Dimensions sheet delta[®] MDL, material versions TT and SS - dimensions in mm

Material versions TT	A	B	C	D	E
100150	243.9	150.1	105.1	159.1	∅49
100600	243.9	150.1	105.1	159.1	∅49
101500	256.2	150.1	92.3	161.1	∅49

Material versions SS	A	B	C	D	E
600150	256.2	150.1	92.3	161.1	∅49
400600	254.7	150.1	99	159.1	∅49
201500	256.2	150.1	92.3	161.1	∅49

18 Diagrams for setting the metering capacity

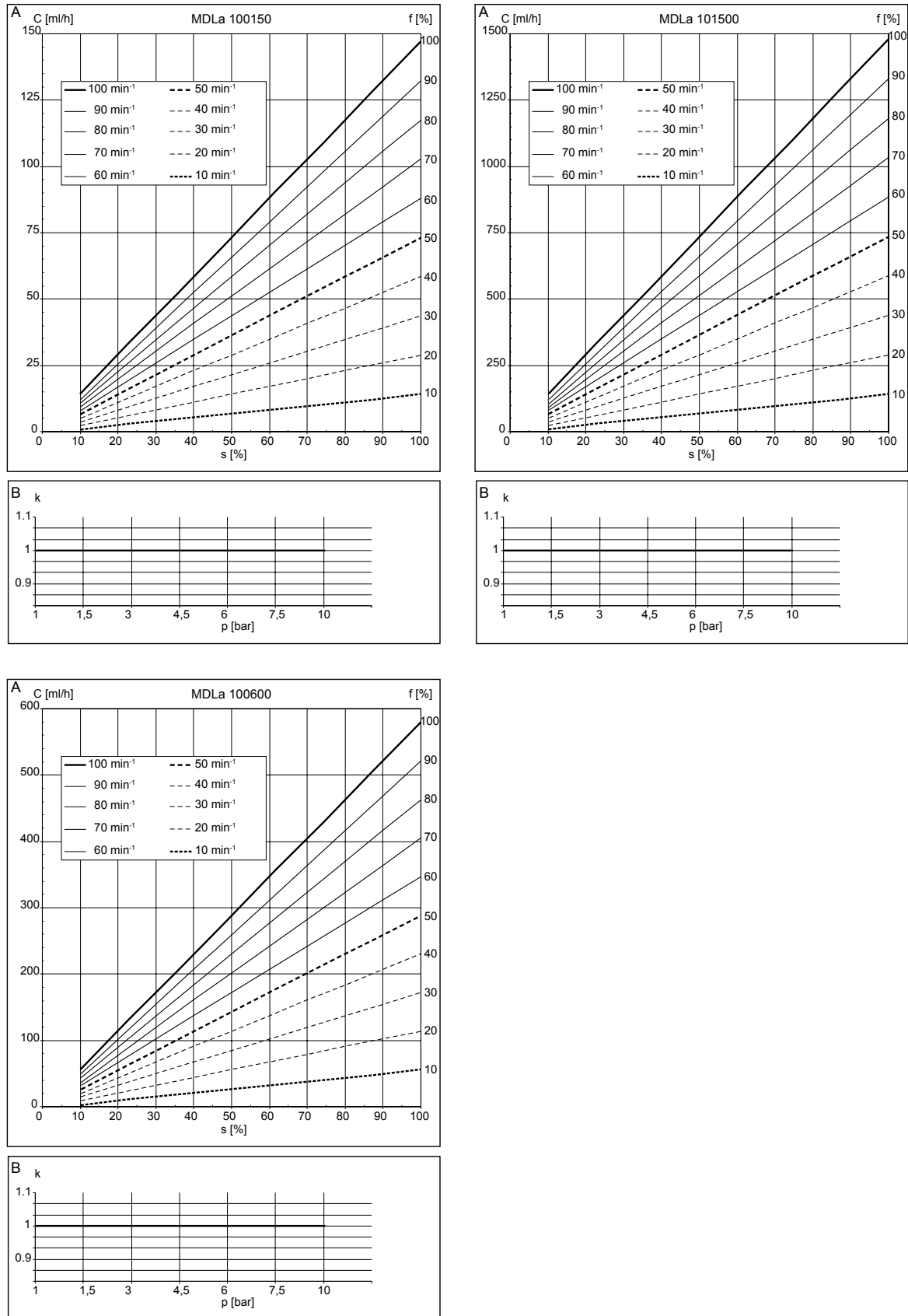

Fig. 33: A) Metering capacity C at medium back pressure dependent on the stroke length s for different stroke rates f . - B) Corresponding correction factors k dependent on the back pressure p .

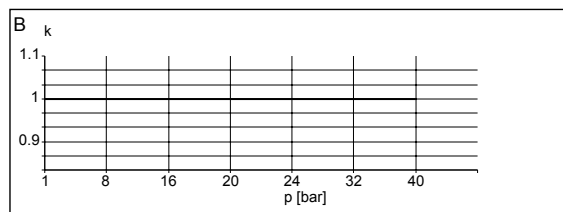
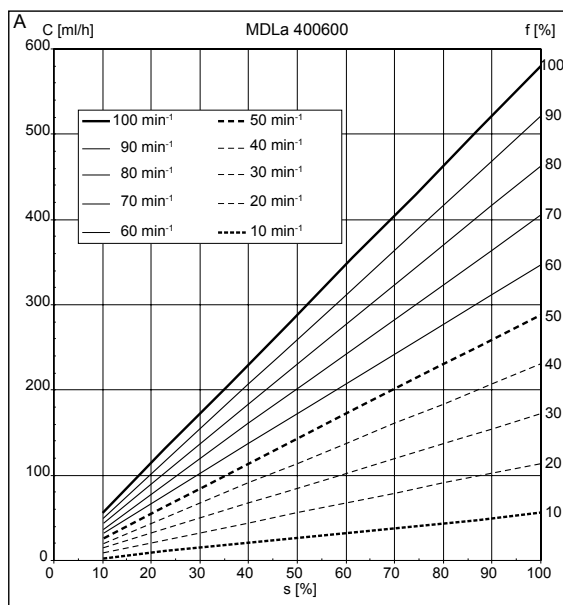
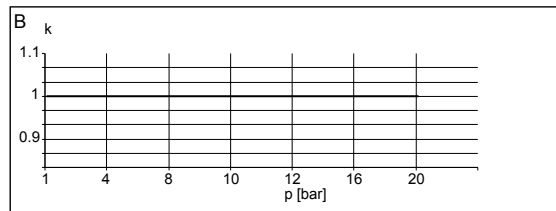
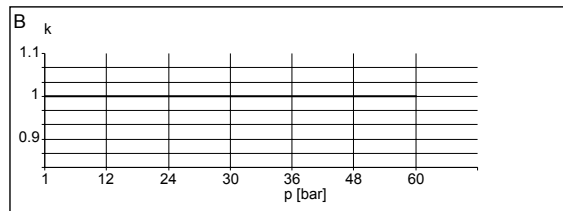
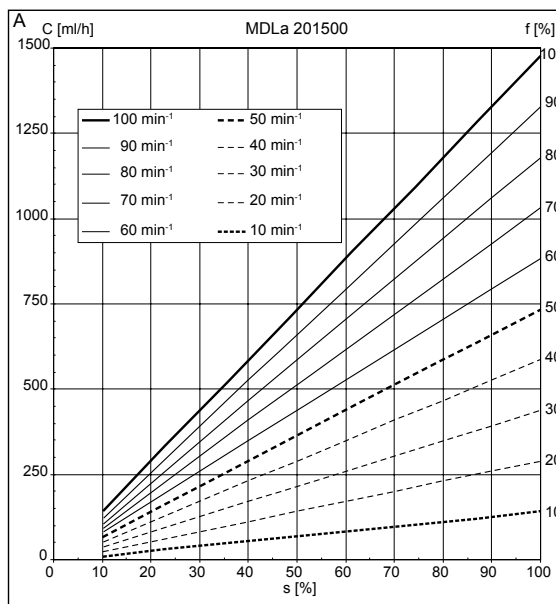
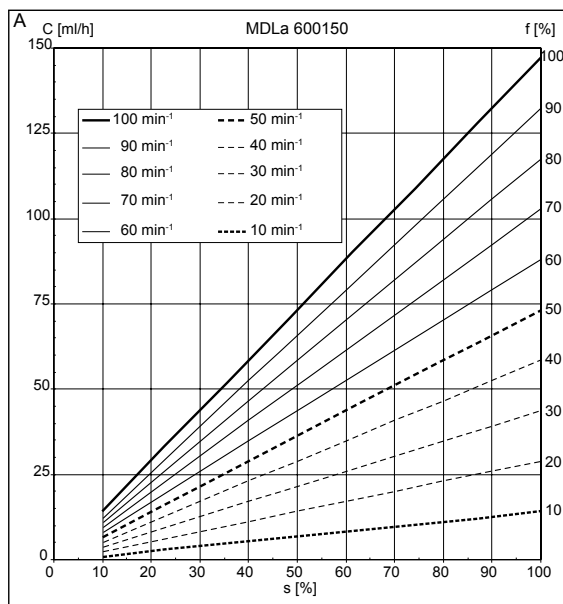
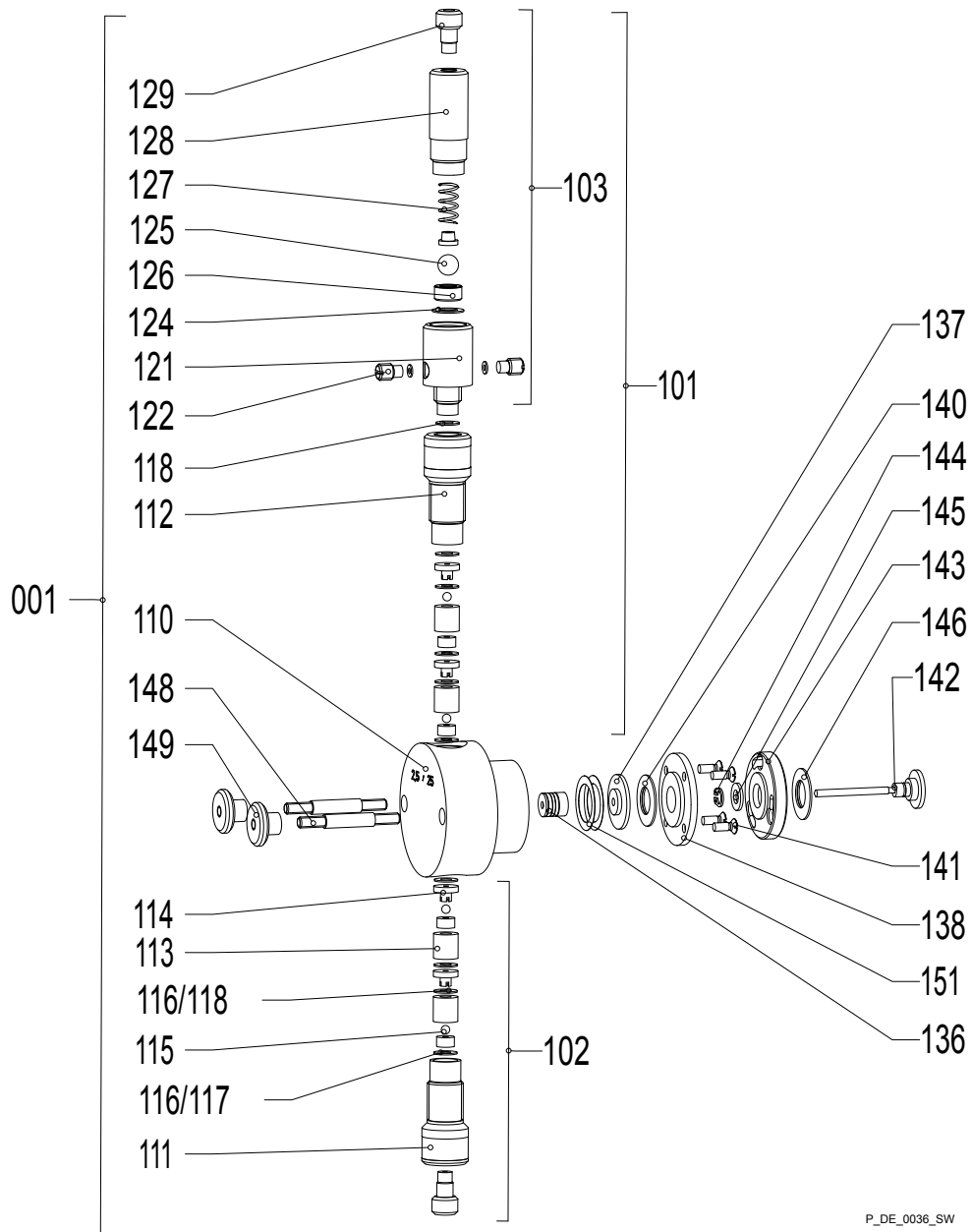

Fig. 34: A) Metering capacity C at medium back pressure dependent on the stroke length s for different stroke rates f . - B) Corresponding correction factors k dependent on the back pressure p .

19 Exploded view drawings

Liquid end mikro delta®100150 -
101500, TT



P_DE_0036_SW

Fig. 35: Liquid end mikro delta®100150 - 101500, TT

Liquid end mikro delta® 600150 - 201500, SS

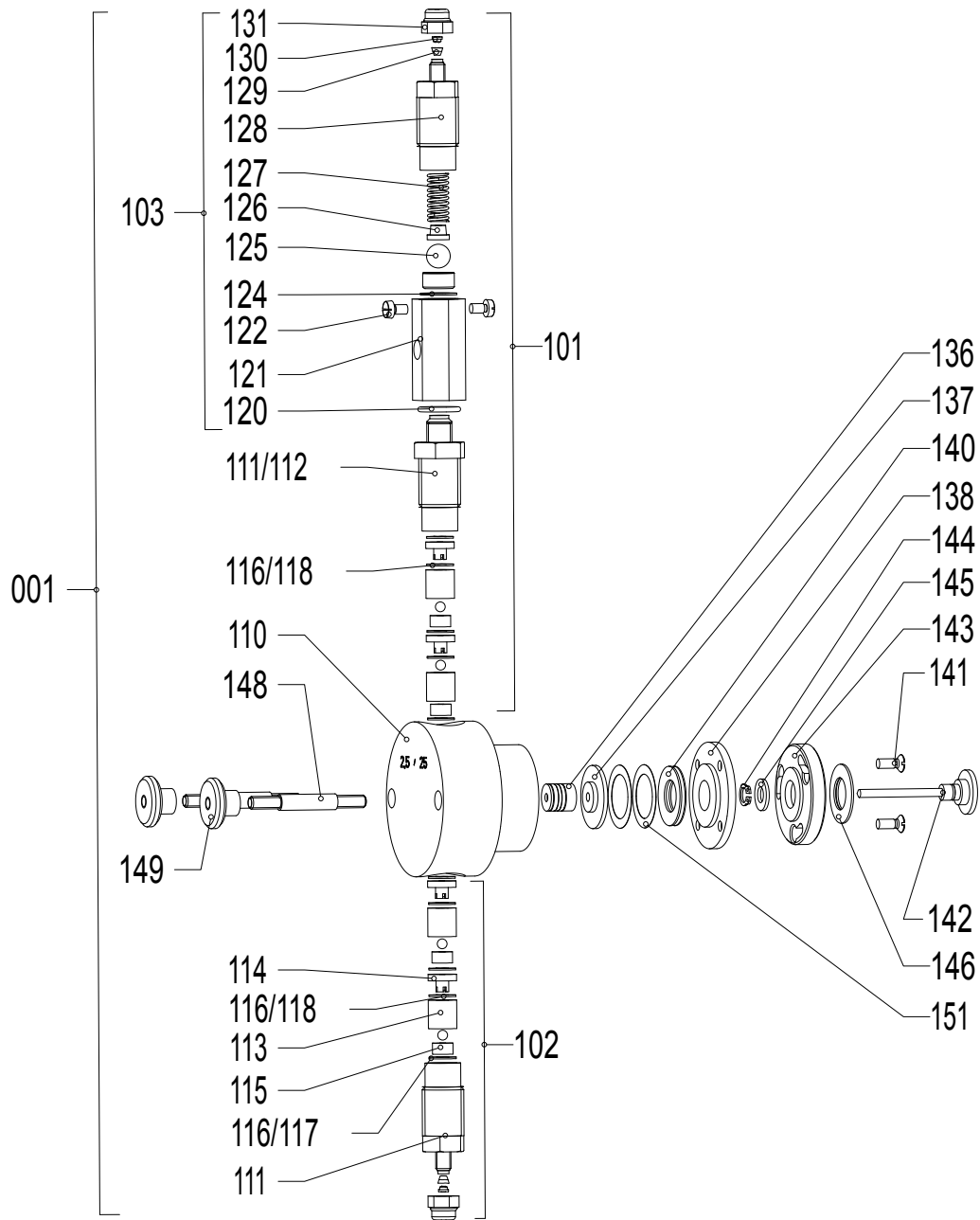

P_DE_0035_SW

Fig. 36: Liquid end mikro delta® 600150 - 201500, SS

20 Ordering Information

Spare parts list TT_

Legend:

A, B - Type 100150

C, D - Type 100600

E, F - Type 101500

Pos.Type	Anz.	Artikel	Description	Best.Nr.
Pos.Type	No. of			Code No.
MDLa Fördereinheiten TT			MDLa Liquid ends TT	
001 A	1,000	Fördereinheit mikro 2.5/ 50 TTT	Liquid end mikro 2.5/ 50 TTT	803176
001 B	1,000	Fördereinheit mikro 2.5/ 50 TTG	Liquid end mikro 2.5/ 50 TTG	803324
001 C	1,000	Fördereinheit mikro 5/ 200 TTT	Liquid end mikro 5/ 200 TTT	803177
001 D	1,000	Fördereinheit mikro 5/ 200 TTG	Liquid end mikro 5/ 200 TTG	803326
001 E	1,000	Fördereinheit mikro 8/ 500 TTT	Liquid end mikro 8/ 500 TTT	803178
001 F	1,000	Fördereinheit mikro 8/ 500 TTG	Liquid end mikro 8/ 500 TTG	803328
101 A-B	1,000	Druckanschluß m. DHV TK2.5 PTFE	Discharge conn.w.DHV TK2.5 PTFE	803276
101 C-D	1,000	Druckanschluß m. DHV TK5.0 PTFE	Discharge conn.w.DHV TK5.0 PTFE	803277
101 E-F	1,000	Druckanschluß m.DHV TK8.0 PTFE	Discharge conn.w.DHV TK8.0 PTFE	803278
102 A-B	1,000	Sauganschluß kpl.zum TK2.5 PTFE	Suction conn. cpl. f.TK2.5 PTFE	803270
102 C-D	1,000	Sauganschluß kpl.zum TK5.0 PTFE	Suction conn. cpl. f.TK5.0 PTFE	803271
102 E-F	1,000	Sauganschluß kpl.zum TK8.0 PTFE	Suction conn. cpl. f.TK8.0 PTFE	803272
103 A-D	1,000	D-H-Ventil 50-200ml T-Keram.	Backpre.valve 50-200ml T-ceram.	803106
103 E-F	1,000	D-H-Ventil 500ml T-Keram.	Backpre.valve 500ml T-ceram.	803107
110 A-B	1,000	Dosierkopf d2.5 mikro T	Dosing head d2.5 mikro T	803083
110 C-D	1,000	Dosierkopf d5,0 mikro T	Dosing head d5,0 mikro T	790324
110 E-F	1,000	Dosierkopf d8,0 mikro T	Dosing head d8,0 mikro T	803085
111 A-D	1,000	Anschlußstück Saugseite PTFE	Connection suction side PTFE	803057
111 E-F	1,000	Anschlußstück Saugseite PTFE	Connection suction side PTFE	803058
112 A-D	1,000	Anschlußstück Druckseite PTFE	Connection pressure side PTFE	803117
112 E-F	1,000	Anschlußstück Druckseite PTFE	Connection pressure side PTFE	803118
113 A-B	4,000	Ventilbüchse Unterteil PTFE	Valve bushing underpart PTFE	803076
113 C-D	4,000	Ventilbüchse Unterteil PTFE	Valve bushing underpart PTFE	803078
113 E-F	4,000	Ventilbüchse Unterteil PTFE	Valve bushing underpart PTFE	803088
114 A-B	4,000	Ventilbüchse Oberteil I PTFE	Valve bushing upper part PTFE	803077
114 C-D	4,000	Ventilbüchse Oberteil I PTFE	Valve bushing upper part PTFE	803079
114 E-F	4,000	Ventilbüchse Oberteil I PTFE	Valve bushing upper part PTFE	803089
115 A-B	4,000	Ventilsitz + Kugel d3.1 Keramik	Valve seat + ball d3.1 ceramic	404825
115 C-D	4,000	Ventilsitz + Kugel d4.7 Keramik	Valve seat + ball d4.7 ceramic	404826
115 E-F	4,000	Ventilsitz + Kugel d7.5 Keramik	Valve seat + ball d7.5 ceramic	404827
116 A-B	11,000	Flachdtg. 8.5x 4.0x0.5 PTFE	Gasket 8.5x 4.0x0.5 PTFE	483915
117 C-D	7,000	Flachdtg. 8.5x 4.0x0.5 PTFE	Gasket 8.5x 4.0x0.5 PTFE	483915
117 E-F	6,000	Flachdtg.11.5x 7.0x0.5 PTFE	Gasket 11.5x 7.0x0.5 PTFE	483917
118 C-D	4,000	Flachdtg. 8.5x 6.0x0.5 PTFE	Gasket 8.5x 6.0x0.5 PTFE	483916
118 E-F	4,000	Flachdtg.11.5x 9.5x0.5 PTFE	Gasket 11.5x 9.5x0.5 PTFE	483918
119 A-B **	4,000	Ventilfeder d0.3/DA 2.3 0.1bar 1.4571	Valve spring d0.3/DA 2.3 0.1bar 1.4571	469437

Fig. 37: Spare parts list TT_, S. 1

Ordering Information

Pos.Type	Anz.	Artikel	Description	Best.Nr.
Pos.Type	No. of	No.		Code No.
MDLa Fördereinheiten TT			MDLa Liquid ends TT	
119 C-D **	4,000	Ventilfeder d0.3/DA 4.0 0.1bar 1.4571	Valve spring d0.3/DA 4.0 0.1bar 1.4571	469438
119 E-F **	4,000	Ventilfeder d0.4/DA 4.9 0.1bar 1.4571	Valve spring d0.4/DA 4.9 0.1bar 1.4571	469439
120 E-F	1,000	Flachdtg. 8.5x 4.0x0.5 PTFE	Gasket 8.5x 4.0x0.5 PTFE	483915
121 A-F	1,000	Verbindungsstück M10-R1/4" PTFE	Connection M10-R1/4" PTFE	803110
122 A-F	2,000	Gewindestift mit Zapfen PTFE	Grub screw with cog PTFE	803120
123 A-F **	2,000	Flachdtg. 4.5x 2.0x0.5 PTFE	Gasket 4.5x 2.0x0.5 PTFE	483914
124 A-F	1,000	Flachdtg. 11.5x 7.0x0.5 PTFE	Gasket 11.5x 7.0x0.5 PTFE	483917
125 A-F	1,000	Ventilsitz + Kugel d7.5 Keramik	Valve seat + ball d7.5 ceramic	404827
126 A-F	1,000	Kugelteller PTFE	Ball plate PTFE	803115
127 A-D	1,000	Druckfeder d0.8 HC4 DFP besch.	Comp.spring d0.8 HC4 DFP coat.	818591
127 E-F	1,000	Ventilfeder d0.6/DA 6.8 0.5bar HC4/DFP	Valve spring d0.6/DA 6.8 0.5bar HC4/DFP	818590
128 A-F	1,000	Anschlußstück UNF 1/4 -28 PTFE	Connection UNF 1/4 -28 PTFE	803111
129 A-D	2,000	Schraubfitting 1/4"-UNF-28 (1/16")	Screwed socket 1/4"-UNF-28 (1/16")	358220
129 E-F	2,000	Schraubfitting 1/4"-28-UNF (1/8")	Screwed socket 1/4"-28-UNF (1/8")	358221
130 A-D **	1,000	Schlauch 1/16" PTFE Mikro	Tube 1/16" PTFE Mikro	803155
130 E-F **	2,000	Schlauch 1/8" PTFE Mikro	Tube 1/8" PTFE Mikro	803156
136 A	1,000	PTFE-Mansch.-Satz d2.5 PTFE weiß	PTFE-collar-set d2.5 PTFE white	485431
136 B	1,000	PTFE-Mansch.-Satz d2.5 Graphit	PTFE-collar-set d2.5 graphite	485428
136 C	1,000	PTFE-Mansch.-Satz d5 PTFE weiß	PTFE-collar -set d5 PTFE white	485430
136 D	1,000	PTFE-Mansch.-Satz d5 Graphit	PTFE-collar -set d5 graphite	485427
136 E	1,000	PTFE-Mansch.-Satz d8 PTFE weiß	PTFE-collar-set d8 PTFE white	485432
136 F	1,000	PTFE-Mansch.-Satz d8 Graphit	PTFE-collar-set d8 graphite	485429
137 A-B	1,000	Druckteller d20xd2.7 S	Pressure plate d20xd2.7 S	803090
137 C-D	1,000	Druckteller d20xd5.2 S	Pressure plate d20xd5.2 S	803091
137 E-F	1,000	Druckteller d20xd8.2 S	Pressure plate d20xd8.2 S	803092
138 A-F	1,000	Spannscheibe Mikro	Conical spring washer Mikro	803093
140 A-B	2,000	Tellerfeder 20x10.2/0.5FEP besch	Disc spring 20x10.2/0.5FEP coat	803240
140 C-F	3,000	Tellerfeder 20x10.2/0.4FEP besch	Disc spring 20x10.2/0.4FEP coat	803241
141 A-F	4,000	Senkschraube DIN 964 M 3x12 A4	Cntrsunk screw DIN 964 M 3x12 A4	461903
142 A-B	1,000	Kolben kpl. d2.5 Zirkonox.Mikro	Piston cpl. d2.5 zirkonia Mikro	803149
142 C-D	1,000	Kolben kpl. d5.0 Keramik Mikro	Piston cpl. d5.0 ceramic Mikro	803181
142 E-F	1,000	Kolben kpl. d8.0 Keramik Mikro	Piston cpl. d8.0 ceramic Mikro	803182
143 A-F	1,000	Kupplungs-Deckel Mikro	Clutch plate Mikro	803087
144 A-B	1,000	Sicherungsring DIN 471 5x0.6 1.4310	Snap ring DIN 471 5x0.6 1.4310	467235
144 C-F	1,000	Sicherungsring DIN 471 8x0.8 1.4310	Snap ring DIN 471 8x0.8 1.4310	467238
145 A-B	1,000	Paßscheibe PS 5x10x1 1.4310	Adj.washer PS 5x10x1 1.4310	460305
145 C-F	1,000	Paßscheibe PS 8x14x1 1.4310	Adj.washer PS 8x14x1 1.4310	460308
146 A-F	2,000	Tellerfeder 18.8x10.2/0.35 Mikro	Disc spring 18.8x10.2/0.35 Mikro	469804
148 A-F	2,000	Stehbolzen M4 mikro	stud bolt M4 mikro	803021
149 A-F	2,000	Rändelmutter DIN 466 M 4 A2	Knurled nut DIN 466 M 4 A2	466224
151 A-F	2,000	Paßscheibe DIN 988 14x20x0.1 1.4310	Shim ring DIN 988 14x20x0.1 1.4310	790309
160 A-F	1,000	Bördeldorn f.PTFE Anschlüsse	Bordering tool f.PTFE connection	803172

Fig. 38: Spare parts list TT, S. 2

Spare parts list SS_

Legend:

A, B - Type 600150

C, D - Type 400600

E, F - Type 201500

Pos.Type	Anz.	Artike l	Description	Best.Nr .
Pos.Type	No.of			Code No.
MDLa Fördereinheiten SS			MDLa Liquid ends SS	
001 A	1,000	Fördereinheit mikro 2.5/ 25 SS T	Liquid end mikro 2.5/ 25 SST	1039159
001 B	1,000	Fördereinheit mikro 2.5/ 25 SSG	Liquid end mikro 2.5/ 25 SSG	1039160
001 C	1,000	Fördereinheit mikro 5/ 100 SST	Liquid end mikro 5/ 100 SST	1039161
001 D	1,000	Fördereinheit mikro 5/ 100 SSG	Liquid end mikro 5/ 100 SSG	1039162
001 E	1,000	Fördereinheit mikro 8/ 250 SST	Liquid end mikro 8/ 250 SST	1039163
001 F	1,000	Fördereinheit mikro 8/ 250 SSG	Liquid end mikro 8/ 250 SSG	1039174
101 A-B	1,000	Druckanschluß m. DHV SK2.5 VA	Discharge conn.w.DHV SK2.5 VA	803286
101 C-D	1,000	Druckanschluß m. DHV SK5.0 VA	Discharge conn.w.DHV SK5.0 VA	803287
101 E-F	1,000	Druckanschluß m. DHV SK8.0 VA	Discharge conn.w.DHV SK8.0 VA	803288
102 A-B	1,000	Sauganschluß kpl.zum SK2.5 VA	Suction conn. cpl. f.SK2.5 VA	803280
102 C-D	1,000	Sauganschluß kpl.zum SK5.0 VA	Suction conn. cpl. f.SK5.0 VA	803281
102 E-F	1,000	Sauganschluß kpl.zum SK8.0 VA	Suction conn. cpl. f.SK8.0 VA	803282
103 A-D	1,000	D-H-Ventil 50-200ml VA-Keram.	Backpre.valve 50-200ml VA-ceram.	803112
103 E-F	1,000	D-H-Ventil 500ml VA-Keram.	Backpre.valve 500ml VA-ceram.	803109
110 A-B	1,000	Dosierkopf d2,5 mikro S	Dosing head d2,5 mikro S	790175
110 C-D	1,000	Dosierkopf d5,0 MG5a S	Dosing head d5,0 MG5a S	790176
110 E-F	1,000	Dosierkopf d8,0 MG5a S	Dosing head d8,0 MG5a S	803082
111 A-D	1,000	Anschlußstück UNF 10-32 S	Connection UNF 10-32 S	803065
111 E-F	2,000	Anschlußstück UNF 5/16-20 S	Connection UNF 5/16-20 S	803066
112 A-D	1,000	Anschlußstück UNF 5/16-20 S	Connection UNF 5/16-20 S	803067
113 A-B	4,000	Ventilbüchse Unterteil 50ul S	Valve bushing underpart 50ul S	803068
113 C-D	4,000	Ventilbüchse Unterteil 200ul S	Valve bushing underpart 200ul S	803124
113 E-F	4,000	Ventilbüchse Unterteil 500ul S	Valve bushing underpart 500ul S	803126
114 A-B	4,000	Ventilbüchse Oberteil 50u l S	Valve bushing upper part 50ul S	803069
114 C-D	4,000	Ventilbüchse Oberteil 200u l S	Valve bushing upper part 200ul S	803123
114 E-F	4,000	Ventilbüchse Oberteil 500u l S	Valve bushing upper part 500ul S	803125
115 A-B	4,000	Ventilsitz + Kugel d3.1 Keramik	Valve seat + ball d3.1 ceramic	404825
115 C-D	4,000	Ventilsitz + Kugel d4.7 Keramik	Valve seat + ball d4.7 ceramic	404826
115 E-F	4,000	Ventilsitz + Kugel d7.5 Keramik	Valve seat + ball d7.5 ceramic	404827
116 A-B	10,000	Flachdtg. 8.5x 4.0x0.5 PTFE	Gasket 8.5x 4.0x0.5 PTFE	483915
117 C-D	6,000	Flachdtg. 8.5x 4.0x0.5 PTFE	Gasket 8.5x 4.0x0.5 PTFE	483915
117 E-F	6,000	Flachdtg.11.5x 7.0x0.5 PTFE	Gasket 11.5x 7.0x0.5 PTFE	483917
118 C-D	4,000	Flachdtg. 8.5x 6.0x0.5 PTFE	Gasket 8.5x 6.0x0.5 PTFE	483916
118 E-F	4,000	Flachdtg.11.5x 9.5x0.5 PTFE	Gasket 11.5x 9.5x0.5 PTFE	483918
119 A-B **	4,000	Ventilfeder d0.3/DA 2.3 0.1bar 1.4571	Valve spring d0.3/DA 2.3 0.1bar 1.4571	469437
119 C-D **	4,000	Ventilfeder d0.3/DA 4.0 0.1bar 1.4571	Valve spring d0.3/DA 4.0 0.1bar 1.4571	469438

Fig. 39: Spare parts list SS_, S. 1

Ordering Information

Pos. Typ Pos. Type	Anz. No. of	Artike l No.	Description	Best.Nr . Code No.
MDLa Fördereinheiten SS			MDLa Liquid ends SS	
119 E-F **	4,000	Ventilfeder d0.4/DA 4.9 0.1bar 1.4571	Valve spring d0.4/DA 4.9 0.1bar 1.4571	469439
120 A-F	1,000	O-Ring 10.50 - 1.50 PTFE	O-ring 10.50 - 1.50 PTFE	481110
121 A-F	1,000	Verbindungsst.UNF 5/16-20 S	Joining piece UNF 5/16-20 S	803074
122 A-F	2,000	Zyl.Schraube DIN 84 M 3x 5 A4	Cyl.screw DIN 84 M 3x 5 A4	461482
123 A-F **	2,000	Flachdgt. 6.0x 3.0x0.5 PTFE	Gasket 6.0x 3.0x0.5 PTFE	483919
124 A-F	1,000	Flachdgt.11.5x 7.0x0.5 PTFE	Gasket 11.5x 7.0x0.5 PTFE	483917
125 A-F	1,000	Ventilsitz + Kugel d7.5 Keramik	Valve seat + ball d7.5 ceramic	404827
126 A-F	1,000	Kugelteller S	Ball plate S	814008
127 A-D	1,000	Ventilfeder d0.8/DA 6.8 2.0bar Hast.C4	Valve spring d0.8/DA 6.8 2.0bar Hast.C4	469410
127 E-F	1,000	Ventilfeder d0.6/DA 6.8 0.5bar Hast.C4	Valve spring d0.6/DA 6.8 0.5bar Hast.C4	469404
128 A-D	1,000	Anschlußstück UNF 10-32 S	Connection UNF 10-32 S	803073
128 E-F	1,000	Anschlußstück UNF 5/16-20 S	Connection UNF 5/16-20 S	803075
129 A-D	2,000	Verspannring 1/16" Edelstahl	Bracing ring 1/16" st.st	359543
129 E-F	2,000	Verspannring 1/8" 1.4571	Bracing ring 1/8" 1.4571	359533
130 A-D	2,000	Druckring 1/16" Edelstahl	Thrust collar 1/16" st.st	359544
130 E-F	2,000	Druckring 1/8" 1.4571	Press.ring 1/8" 1.4571	359532
131 A-D **	2,000	Anschl.mutter 1/16" Edelstahl	Connection nut 1/16" st.st	359545
131 E-F **	2,000	Ü.Mutter 1/8" 1.4571	Union nut 1/8" 1.4571	359534
132 A-D **	2,000	Nippel d 1.5 x0.9 x25 1.4301	Nipple d 1.5 x0.9 x25 1.4301	402315
132 E-F **	2,000	Nippel d 3.175x1.58x30 1.4571	Nipple d 3.175x1.58x30 1.4571	402316
134 A-D **	1,000	Schlauch 1/16" PTFE Mikro	Tube 1/16" PTFE Mikro	803155
134 E-F **	1,000	Schlauch 1/8" PTFE Mikro	Tube 1/8" PTFE Mikro	803156
136 A	1,000	PTFE-Mansch.-Satz d2,5 PTFE weiß	PTFE-collar-set d2,5 PTFE white	485431
136 B	1,000	PTFE-Mansch.-Satz d2,5 Graphit	PTFE-collar-set d2,5 graphite	485428
136 C	1,000	PTFE-Mansch.-Satz d5 PTFE weiß	PTFE-collar-set d5 PTFE white	485430
136 D	1,000	PTFE-Mansch.-Satz d5 Graphit	PTFE-collar-set d5 graphite	485427
136 E	1,000	PTFE-Mansch.-Satz d8 PTFE weiß	PTFE-collar-set d8 PTFE white	485432
136 F	1,000	PTFE-Mansch.-Satz d8 Graphit	PTFE-collar-set d8 graphite	485429
137 A-B	1,000	Druckteller d20xd2.7 S	Pressure plate d20xd2.7 S	803090
137 C-D	1,000	Druckteller d20xd5.2 S	Pressure plate d20xd5.2 S	803091
137 E-F	1,000	Druckteller d20xd8.2 S	Pressure plate d20xd8.2 S	803092
138 A-F	1,000	Spannscheibe Mikro	Conical spring washer Mikro	803093
140 A-B	3,000	Tellerfeder D20x10.2/0.6 besch .	Plate spring D20x10.2/0.6 coat	790217
140 C-D	3,000	Tellerfeder 20x10.2/0.5FEP besch	Disc spring 20x10.2/0.5FEP coat	803240
140 E-F	3,000	Tellerfeder 20x10.2/0.4FEP besch	Disc spring 20x10.2/0.4FEP coat	803241
141 A-F	4,000	Senkschraube DIN 964 M 3x 8 A2	Cntrsunk screw DIN 964 M 3x 8 A2	461902
142 A-B	1,000	Kolben kpl. d2.5 Zirkonox.Mikro	Piston cpl. d2.5 zirkonia Mikro	803149
142 C-D	1,000	Kolben kpl. d5.0 Keramik Mikro	Piston cpl d5.0 ceramic Mikro	803181
142 E-F	1,000	Kolben kpl. d8.0 Keramik Mikro	Piston cpl. d8.0 ceramic Mikro	803182
143 A-F	1,000	Kupplungs-Deckel Mikro	Clutch plate Mikro	803087
144 A-B	1,000	Sicherungsring DIN 471 5x0.6 1.4310	Snap ring DIN 471 5x0.6 1.4310	467235
144 C-F	1,000	Sicherungsring DIN 471 8x0.8 1.4310	Snap ring DIN 471 8x0.8 1.4310	467238
145 A-B	1,000	Paßscheibe PS 5x10x1 1.4310	Adj.washer PS 5x10x1 1.4310	460305
145 C-F	1,000	Paßscheibe PS 8x14x1 1.4310	Adj.washer PS 8x14x1 1.4310	460308
146 A-F	2,000	Tellerfeder 18.8x10.2/0.35 Mikro	Disc spring 18.8x10.2/0.35 Mikro	469804
148 A-F	2,000	Stehbolzen M4 mikro	stud bolt M4 mikro	803021
149 A-F	2,000	Rändelmutter DIN 466 M 4 A2	Knurled nut DIN 466 M 4 A2	466224
151 A-F	2,000	Paßscheibe DIN 988 14x20x0.1 1.4310	Shim ring DIN 988 14x20x0.1 1.4310	790309

Fig. 40: Spare parts list SS_, S. 2

Further sources of information

Further information on spare parts, accessories and options can be found in:

- the exploded drawings
- the identity code
- the "General Operating Instructions on ProMinent® solenoid dosing pumps".
- the ProMinent® Equipment catalogue

21 EC Declaration of Conformity

- Original -	
EC Declaration of Conformity for Machinery	
We,	ProMinent Dosiertechnik GmbH Im Schuhmachergewann 5 - 11 D - 69123 Heidelberg
<p>hereby declare that the product identified below conforms to the basic health and safety requirements of the EC Directive, by virtue of its design and construction, and in the configuration placed on the market by us. This declaration is no longer applicable if changes are made to the product without our authorisation.</p>	
Product description:	<i>Dosing pump, mikro delta series</i>
Product type:	<i>MDLa...</i>
Serial no.:	<i>see type plate on the unit</i>
Applicable EC Directives:	<i>EC Machinery Directive (2006/42/EC) EC EMC Directive (2004/108/EC) The safety objectives of the Low Voltage Directive 2006/95/EC were complied with in accordance with Appendix 1, No. 1.5.1 of the Machinery Directive 2006/42/EC</i>
Applied harmonised standards, especially:	<i>EN ISO 12100, EN 809, EN 61010-1, EN 60335-2-41, EN 61000-3-2/3, EN 61000-6-1/2/3/4</i>
Technical documentation was compiled by the authorised representative for documentation:	<i>Dr. Johannes Hartfiel Im Schuhmachergewann 5-11 D - 69123 Heidelberg</i>
Date / Manufacturer signature:	<i>08.03.2012</i> 
Name / position of the signatory:	<i>Joachim Schall, Manager Innovation and Technology</i>

22 Decontamination declaration

Declaration of Decontamination

(see download: www.prominent.com)

Because of legal regulations and for the safety of our employees and operation equipment, we need the „declaration of decontamination“, with your signature, before your order can be handled.

Please make absolutely sure to include it with the shipping documents, or – even better – attach it to the outside of the packaging.

Please return your products to:

Type of instrument / sensor: _____ **Serial number:** _____
 Gerätetyp: _____ Seriennummer: _____

Process data: Temperature: _____ [°C] Pressure: _____ [bar]
 Prozessdaten: Temperatur: _____ Druck: _____

Mediums and warnings:

Warnhinweise zum Medium:



	Medium/ Concentration Medium/ Konzentration	Identi- fication CAS No.	flammable entzünd- lich	toxic giftig	corrosive ätzend	harmful/ irritant gesundheits- schädlich/reizend	other* sonstiges*	harmless unbedenklich
Process medium Medium im Prozess								
Medium for process-cleaning Medium zur Prozessreinigung								
Returned part cleaned with Medium zur Endreinigung								

* explosive; oxidising; dangerous for the environment; biological risk; radioactive
 * explosiv; brandfördernd; umweltgefährlich; biogefährlich; radioaktiv

Please tick should one of the above be applicable, include security sheet and, if necessary, special handling instructions.

Reason for return:

Company data:

Company: _____ Phone number: _____
 Contact person: _____ Fax: _____
 Street: _____ E-Mail: _____
 Address: _____ Your order No: _____

“We hereby certify that the returned parts have been carefully cleaned. To the best of our knowledge they are free from any residues in dangerous quantities.”

Place, date

Company stamp and legally binding signature

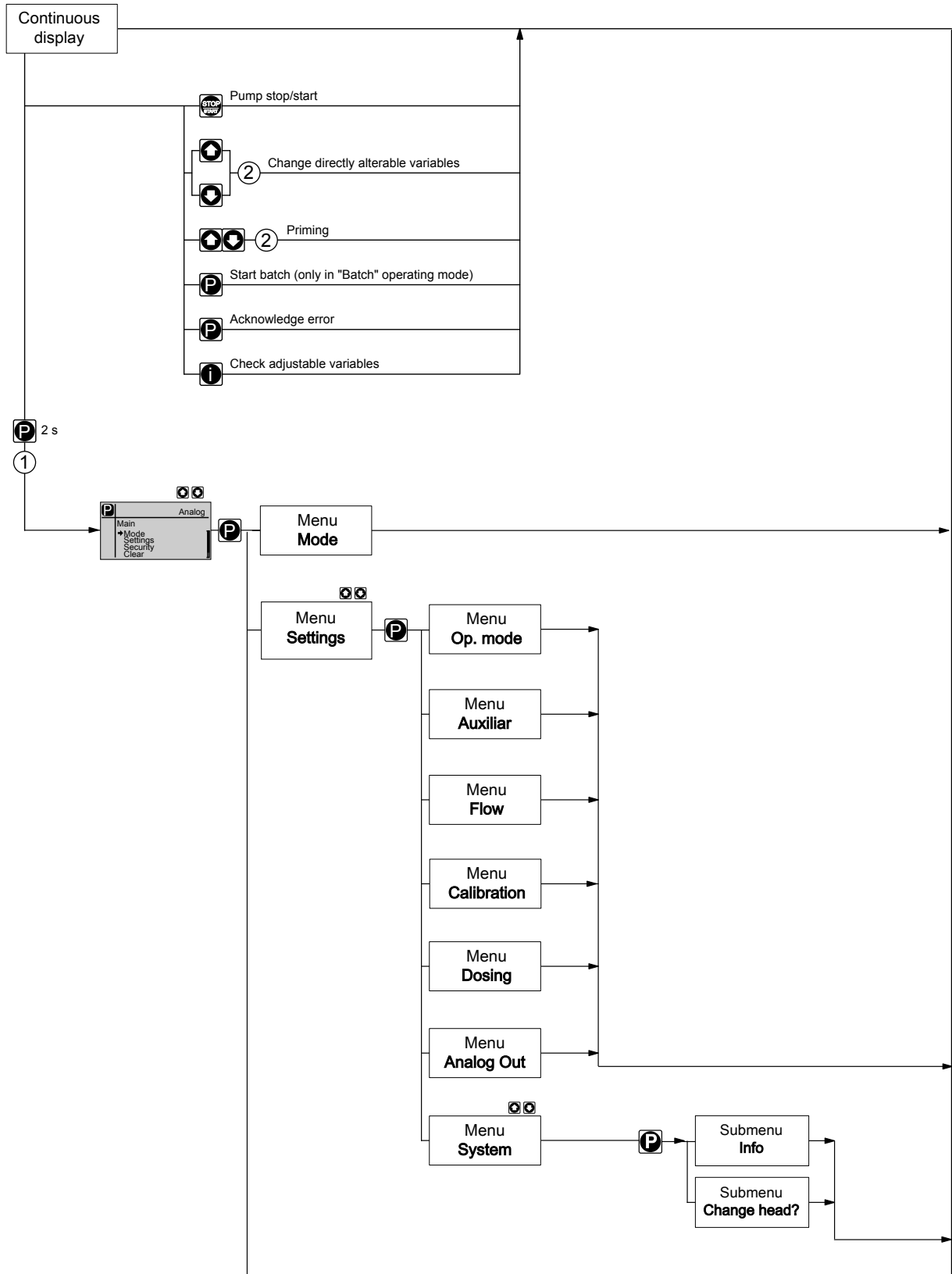

23 Operating / adjustment overview

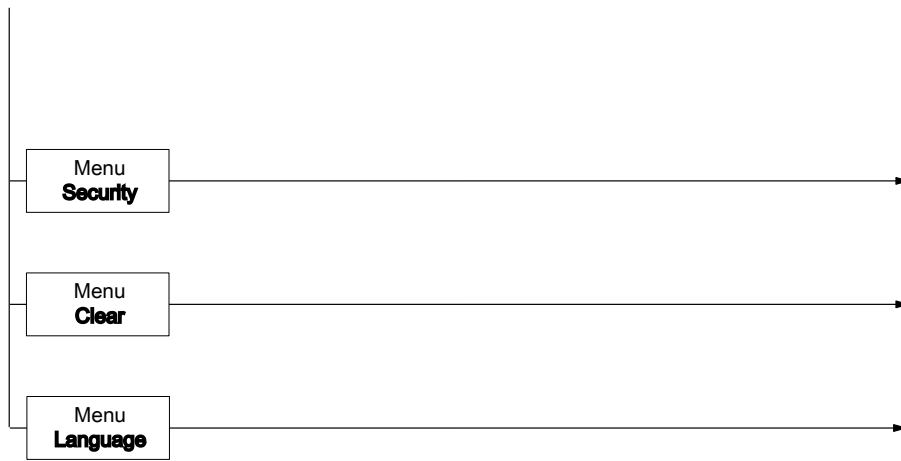

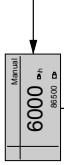
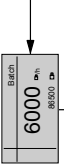
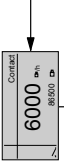
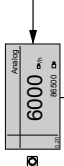
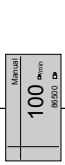
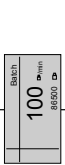
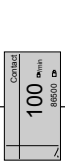
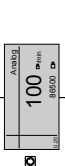
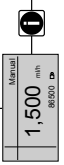
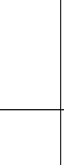
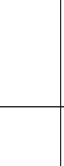

24 Continuous displays

Continuous display

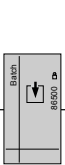
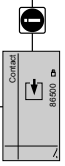
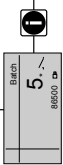
Continuous display	Op. mode "Manual"	Op. mode "Batch" with Memory and transfer factor 5	Op. mode "Contact" with Memory and transfer factor 5	Op. mode "Analog"
Stroke rate (Strokes/h)				
Stroke rate (Strokes/min)				
Capacity				
Display "External"				
Factor				

 = with the arrow keys [Up] and [Down] directly alterable variables
 Identifier "m" only, should function extension "Stroke memory" be activated.

Auxiliary displays in the continuous display

Auxiliary display	Op. mode "Manual"	Op. mode "Batch" with Memory and transfer factor 5	Op. mode "Contact" with Memory and transfer factor 5	Operating mode "Analog"
Stroke rate (Strokes/h)	6000 CP/h	6000 CP/h	6000 CP/h	6000 CP/h
Stroke rate (Strokes/min)	100 CP/min	100 CP/min	100 CP/min	100 CP/min
Capacity	80,00 ml/h ¹			80,00 ml/h ¹
Factor			5 *	
Remaining strokes		25,00		
Batch size Remaining litres		000,833		
Total strokes	86500 CP	86500 CP	86500 CP	86500 CP
Total litres (Dosing amount)	576,67 ml ¹	576,67 ml ¹	576,67 ml ¹	576,67 ml ¹
Stroke length	65 %	65 %	65 %	65 %
Signal current (at the input)				12,7 mA ³
Dosing mode	: slow, : HV1	: slow, : HV1	: slow, : HV1	: slow, : HV1

1 = only after running through the CALIBRATION menu - also after every change of operating mode

2 = only with function extension "Memory"

3 = only with current output

25 Index

.....	63	Disposal.....	71
"		Dosing head.....	63
"Diaphragm rupture reporter" jack.....	16	Dosing monitor.....	31
"Dosing monitor" jack.....	16	E	
"External control" jack.....	16	Emergency.....	11
"External control" terminal.....	30	Emptying the liquid end.....	70
"Level Switch" jack.....	16	Explanation of the safety instructions.....	8
1, 2, 3 ...		External contact.....	23, 30, 31
4 - 20 mA.....	41	External frequency changeover.....	23
A		F	
Adjustment, chapter.....	34	Factor.....	38, 39
Adjustment mode.....	35	Fault.....	23
AH.....	51	Fault indicating and pacing relay option.....	22
Analog.....	21, 41	Fault indicating relay.....	22, 32, 33
Analog output.....	30, 50	Fault indicator (red).....	16, 23
AS.....	51	Fault processing.....	43
Assembly.....	24	Fault statuses.....	23
AUX.....	44	Flow.....	21, 44
Auxiliary frequency.....	30, 31, 44	Functional description.....	20
Auxiliary rate.....	21, 22, 23	Functions.....	23
B		Function settings.....	44
Back pressure valve.....	15	G	
Basic principles of control adjustment.....	34	Gaseous feed chemicals.....	47
Batch.....	21, 38	Grounding screw.....	15
Bus.....	16	H	
C		Hardware control HW.....	51
Calibrate.....	21, 45	Hardware drive AH.....	51
Capacity.....	20	Hardware option OH.....	51
Cavitation.....	47	Hierarchy of operating modes.....	23
Change head?.....	51	HW.....	51
Checking adjustable values.....	34	Hydraulic installation.....	25
CLEAR.....	53	I	
Code.....	52	ID.....	51
Contact.....	21, 39	Identity code.....	5
Contact water meter.....	41	Identity code ID.....	51
Continuous displays.....	34	Info.....	51
Control elements.....	16	Information in the event of an emergency.....	11
Correct and proper use.....	8	Installation, electrical.....	28
Curve.....	41	IP.....	74
D		K	
Decommissioning.....	70	Keys.....	16
Decontamination declaration.....	86	L	
Degree of protection.....	74	Language.....	53
Device overview.....	15	LCD display.....	16
Discharge stroke.....	20, 47	Leakage hole.....	58
Discharge valve.....	15	Level.....	32
		Level switch.....	22, 23, 31

Index

Linear.....	42	Safety requirements.....	74
M		Scope of supply.....	14
Mains Cable.....	29	Secondary displays.....	35
Maintenance.....	58	SECURITY.....	52
Manual.....	21, 23, 37	Semiconductor switch.....	33
Manual operation.....	55	Serial number SN.....	51
mA Output.....	22, 30	Sideband.....	43
Memory.....	38, 39	Slot for optional module	16
Metering settings.....	46	Slowing.....	47
N		SN.....	51
Name module-option.....	51	Software control SW.....	51
O		Software drive AS.....	51
OH.....	51	Software option OS.....	51
Operating indicator (green).....	16, 23	Sound pressure level.....	12, 75
Operating modes.....	21, 23	Stop.....	22, 23
Operating mode selection.....	36	Storage.....	13
Operating mode settings.....	36	Stroke length.....	20
Operation.....	36, 54	Stroke length adjustment knob.....	16
optoDrive.....	20	Stroke rate.....	20
OS.....	51	Stroke velocity.....	20
P		Suction stroke.....	20, 47
Pacing relay.....	33	Suction valve.....	15
Packing.....	63	Supply Voltage.....	29
Pause.....	22, 23, 30	SW.....	51
Piston.....	63	System.....	51
Priming.....	23	T	
Protection against contact and humidity.....	74	Test (function).....	23
Protection class.....	74	Total litres.....	53
Protective bush.....	15	Total number of strokes.....	53
Pulse control.....	41	Transport.....	13
Q		U	
Qualification of personnel.....	11	Unpacking.....	13
R		V	
Radioactive.....	13	Vent screw.....	15
Relay.....	16, 22, 32, 48	Viscosity.....	47
Relay behaviour.....	48	V-sleeve set.....	63
Remote operation.....	57	W	
Reproducibility.....	20	Warning alert.....	32
S		Warning indicator (yellow).....	16, 23
Safety chapter.....	8	Warning sign.....	8
Safety declaration form.....	13		



ProMinent Dosiertechnik GmbH
Im Schuhmachergewann 5-11
69123 Heidelberg
Germany
Telephone: +49 6221 842-0
Fax: +49 6221 842-617
email: info@prominent.com
Internet: www.prominent.com

986161, 3, en_GB

" "

www.promhimtech.ru / zakaz@promhimtech.ru

ProMinent