

Liquid ring vacuum pumps

in compact design



LEM 25, LEM 50

Pressure range: 33 to 1013 mbar
Suction volume flow: 4 to 60 m³/h

CONSTRUCTION

SIHI liquid ring vacuum pumps are displacement pumps of uncomplicated and robust construction with the following particular features:

- non-polluting due to nearly isothermal compression
- oil-free, as no lubrication in the working chamber
- handling of nearly all gases and vapours
- small quantities of entrained liquid can be handled
- easy maintenance and reliable operation
- low noise and nearly free from vibration
- wide choice of material, therefore applicable nearly everywhere
- shaft not contact with the medium
- protection against cavitation as standard
- incorporated dirt drain
- incorporated central drain
- no metallic contact of the rotating parts

The SIHI liquid ring vacuum pumps LEM are single-stage ones.

APPLICATION

Handling and exhausting of dry and humid gases; entrained liquid can be handled during normal duty. The pumps are applied in all fields where a pressure of 33 to 900 mbar must be created by robust vacuum pumps.



NOTE

During operation the pump must continuously be supplied with service liquid, normally water, in order to eliminate the heat resulting from the gas compression and to replenish the liquid ring, because part of the liquid is leaving the pump together with the gas. This liquid can be separated from the gas in a liquid separator (see catalogue part accessories).

It is possible to reuse the service liquid. The pumps are equipped with a device by which the contaminated service liquid can continuously be drained during operation (dirt drain), if necessary.

The direction of rotation is clockwise, when looking from the drive on the pump.

GENERAL TECHNICAL DATA

Pump Type	Units	LEM 25	LEM 50
Speed	50 Hz 60 Hz	rpm	
		2900 3500	
Maximum overpressure on compression	bar	0.3	
Permissible pressure difference between suction and discharge side	max. min.	bar	
		1.1 0.2	
Hydraulic test pressure (overpressure)	bar	3	
Moment of inertia of rotating parts of pump and water content	kg · m ²	0.003	0.0095
Noise level at 80 mbar suction pressure	dB (A)	68	69
Maximum gas temperature	dry saturated	°C	
		200 100	
Service liquid	°C	80	
Maximum permissible temperature	mm ² /s	10	
Minimum permissible temperature	kg/m ³	4	
Maximum viscosity	litre	1200	
Maximum density		0.3	0.4
Liquid capacity up to middle of shaft	bar	0.2	
Maximum flow resistance of the heat exchanger			

In selecting a pump, avoid choosing one which is likely to be operating at a combination of its maximum permissible limits e.g. maximum viscosity and maximum permissible pressure difference.

Materials

Item	COMPONENTS	MATERIALS OK
10.10	Vacuum casing	0.6025
10.90	Central body	
13.70	Guide disc	
23.50	Vane wheel impeller	1.4308
-	Steel parts in contact with the medium	1.4401
43.30	Standard mechanical seal	Steatite / Carbon / Butadiene rubber
75.40	Valve balls	polyamide A

Cut-away diagram LEM 25, LEM 50

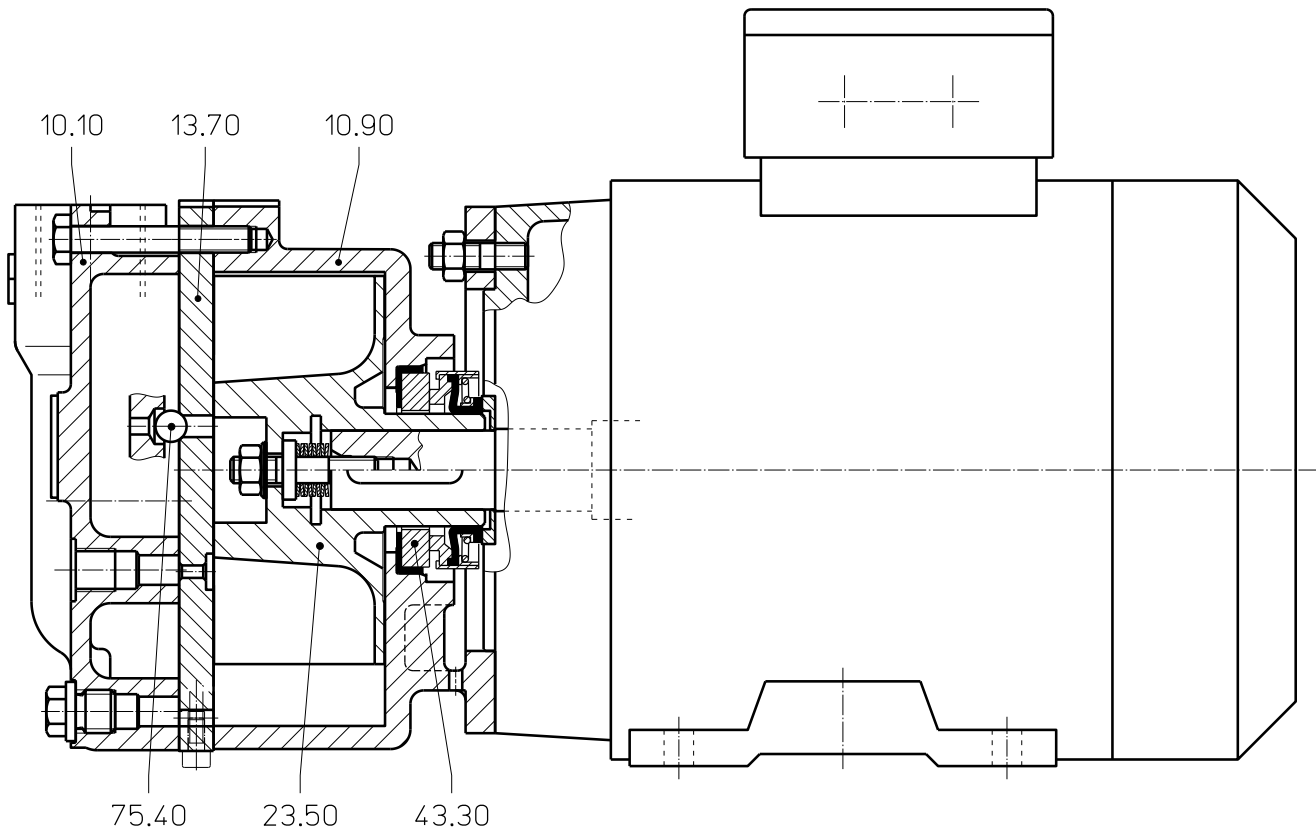

Make-up Liquid Consumption in [m³/h] dependent upon suction pressure, speed, drive type and temperature difference

suction pressure in [mbar]		33			120			200			400						
pump type	speed [rpm]	KB			FB	KB			FB	KB			FB				
		temperature difference [°C]				temperature difference [°C]				temperature difference [°C]							
		10	5	2		10	5	2		10	5	2					
LEM 25	2800	0.04	0.06	0.12	0.26	0.05	0.08	0.13	0.26	0.05	0.08	0.14	0.26	0.05	0.08	0.12	0.2
	3500	0.05	0.09	0.15		0.06	0.10	0.16		0.07	0.11	0.16		0.06	0.10	0.14	
LEM 50	2800	0.07	0.13	0.23	0.5	0.09	0.15	0.25	0.48	0.09	0.15	0.25	0.45	0.09	0.14	0.22	0.35
	3500	0.11	0.18	0.29		0.12	0.20	0.31		0.13	0.20	0.30		0.12	0.18	0.25	

FB = total service liquid flow rate on once-through system

KB = flow of make-up water when combined with partial recirculation liquid at a temperature of 10 °C, 5 °C, 2 °C warmer than make-up water

Performance Characteristics LEM 25

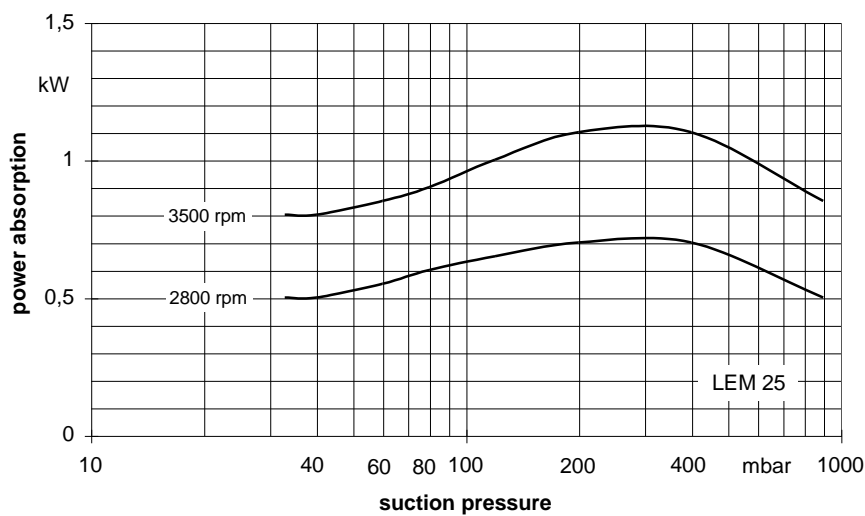
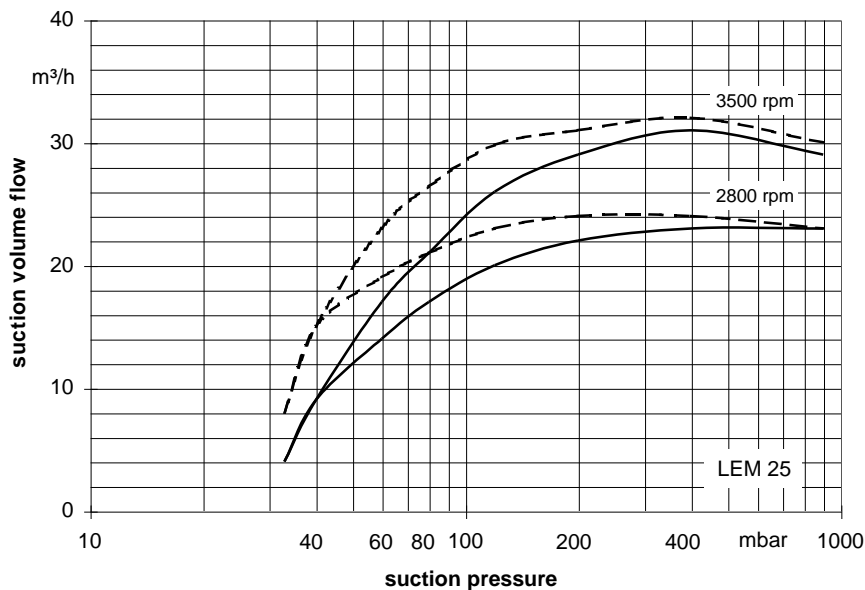

The operating data is valid under the following conditions:

- process media:
 - dry air: 20°C _____
 - steam saturated air: 20°C - - - - -
- service liquid:
 - water: 15°C

Pressure of gas to be evacuated: 1013 mbar (atmospheric pressure)

The suction volume is related to the suction pressure.

Tolerance on operating data is 10%.

The maximum consumption of make-up water occurs at the lowest suction pressure.

Performance Characteristics LEM 50

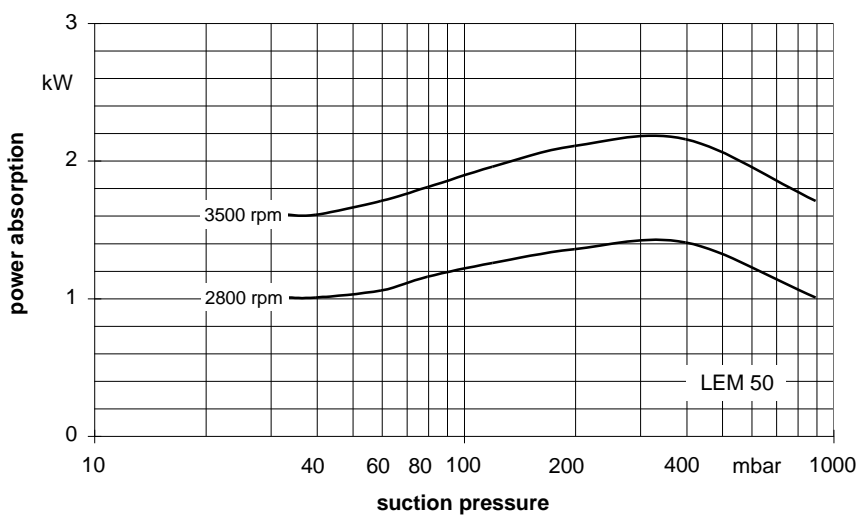
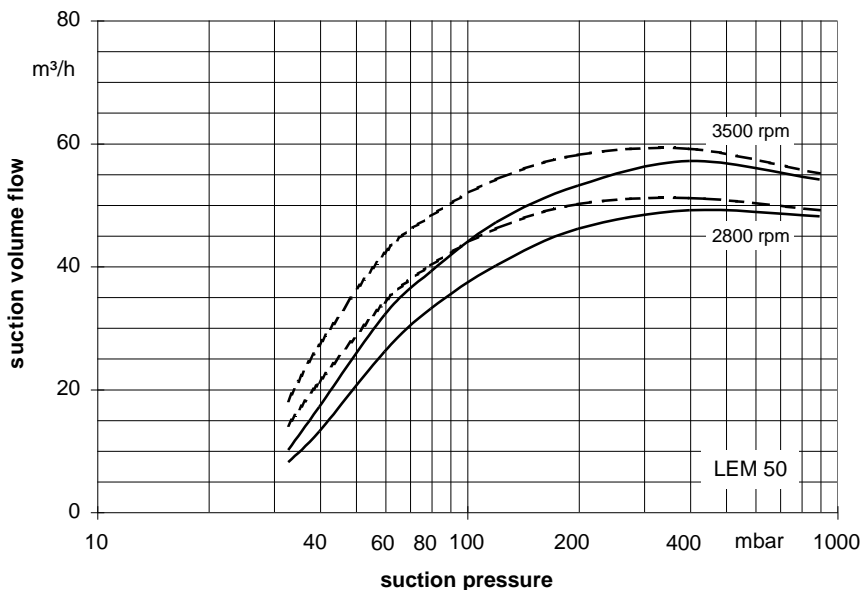

The operating data is valid under the following conditions:

- process media:
 - dry air: 20°C
 - steam saturated air: 20°C
- service liquid:
 - water: 15°C

Pressure of gas to be evacuated: 1013 mbar (atmospheric pressure)

The suction volume is related to the suction pressure.

Tolerance on operating data is 10%.

The maximum consumption of make-up water occurs at the lowest suction pressure.

Dimensions LEM 25

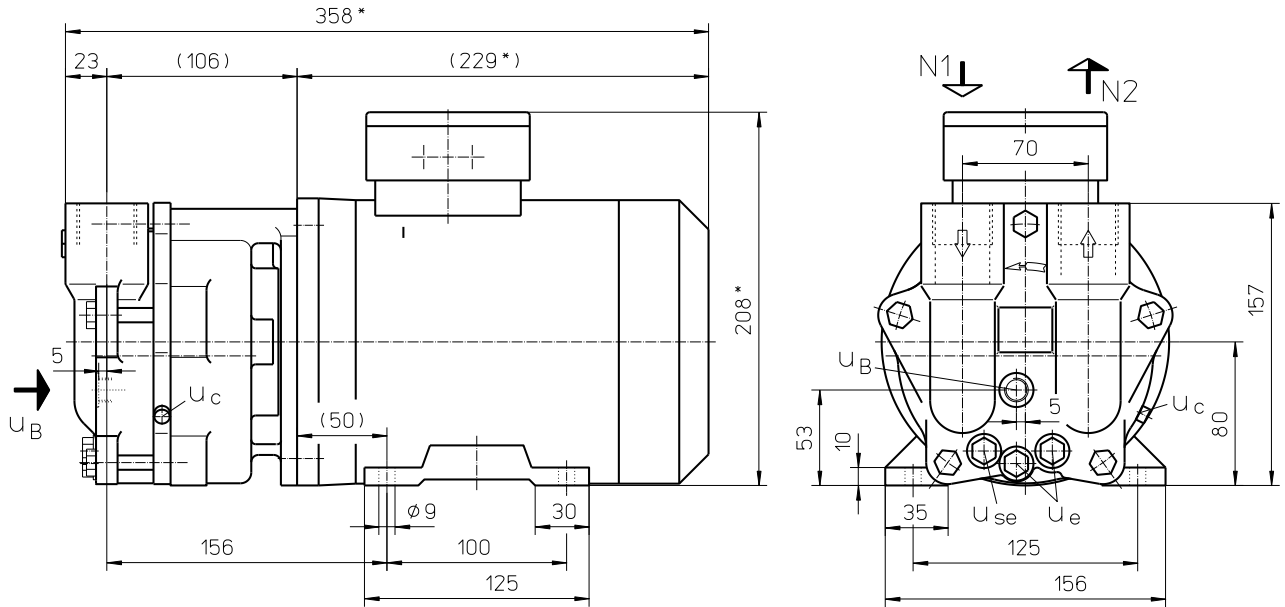

	electric motor IP 55		approx. weight [kg]	
	size	kW		
		50 Hz	60 Hz	
LEM 25	80	0.75	1.1	19

other motors on request

* dimensions dependent upon motor supplier

- N 1 = gas inlet G 1
- N 2 = gas outlet G 1
- u_B = connection for service liquid G ¼
- u_c = connection for protection against cavitation M5
- u_e = connection for drain G ¼
- u_{se} = connection for dirt drain G ¼

Dimensions LEM 50

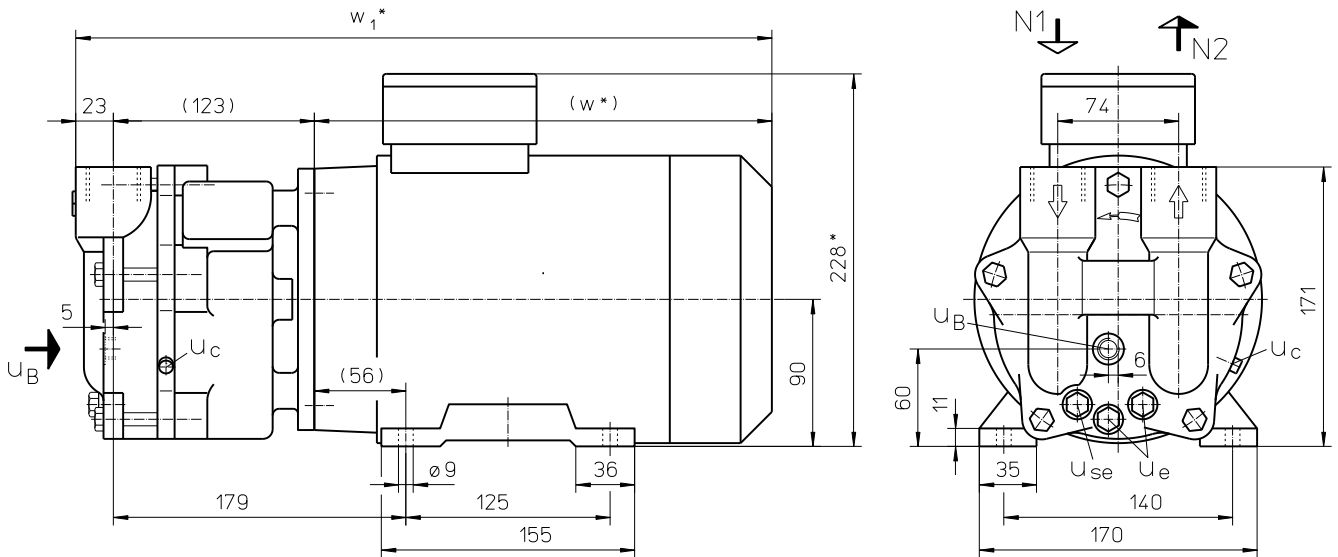

- N 1 = gas inlet G 1
- N 2 = gas outlet G 1
- u_B = connection for service liquid G ¼
- u_c = connection for protection against cavitation M5
- u_e = connection for drain G ¼
- u_{se} = connection for dirt drain G ¼

	electric motor IP 55		w *	w ₁ *	approx. weight [kg]	
	size	kW				
		50 Hz	60 Hz			
LEM 50	90 L	1.5	-	270	416	31
		-	2.2	280	426	37

other motors on request

* dimensions dependent upon motor supplier

Arrangement drawing LEM 25, LEM 50

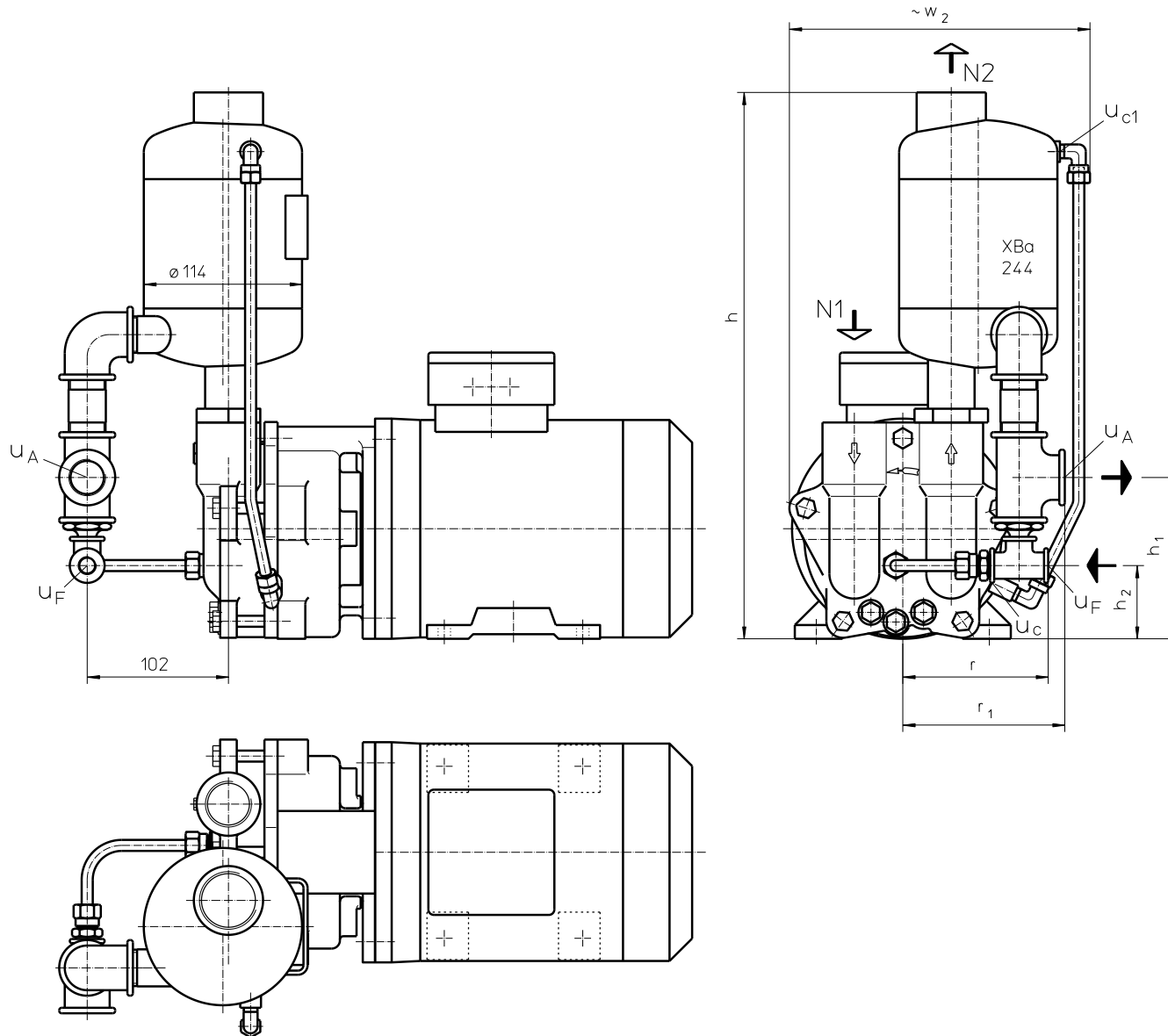

- N 1 = gas inlet G 1
- N 2 = gas outlet G 1 ¼
- u A = liquid overflow G ¾
- u c = connection for protection against cavitation M5
- u c1 = connection for protection against cavitation G 1/8
- u F = connection for make-up liquid G ¼

	h [mm]	h ₁ [mm]	h ₂ [mm]	r [mm]	r ₁ [mm]	w ₂ [mm]	approx. weight [kg]
LEM 25	398	117	54	105	117	217	22
LEM 50	411	123	60	107	119	225	29

Data regarding the pump size - order notes

range + size	hydraulic + bearings	shaft seal	materials	casing sealing
	<ul style="list-style-type: none"> A• hydraulic A •Z two grease lubricated antifriction bearings arranged in the motor 	X1L mechanical seal carbon / butadiene rubber	OK main parts out of cast iron, impeller in low alloyed steel	0 liquid seal
LEM $\frac{25}{50}$	AZ	X1L	OK	0

Motor Selection

For our products we offer a lot of different motor types.
To identify the right motor please specify frequency, voltage and protection class.

Example of an Order:

LEMA 25 AZ X1L OK 0 with 0.75 kW AC motor, 50 Hz, 230V Δ, IP55

Accessories LEM 25, LEM 50

Recommended Accessory	Material execution		LEM 25	LEM 50
Top Mounted Liquid Separator		Type / weight	XBa 244 / 2.8 kg	
Top mounted separator	1.4571	SIHI-Part No.	43 133 503	
Service liquid pipework, standard execution	Steel, galvanised 1.4571	SIHI-Part No.	20 072 997 20 072 998	
Service liquid pipework, thermostatic control 24V	1.0254 + Brass 1.4571 + Brass	SIHI-Part No.	on request 20 072 556	
Cavitation protection pipework	Steel, galvanised 1.4571	SIHI-Part No.	20 050 496 20 050 589	
Sterling SIHI – Gas Ejector see Technical Catalogue – Gas Ejector				
	at service liquid temperature 15 °C	Type / weight	GEV 25 A / 1.1 kg	GEV 50 A / 1.1 kg
	at service liquid temperature 30 °C	Type / weight	GEV 25 A / 1.1 kg	GEV 50 A / 1.1 kg
Sterling SIHI – Non Return Ball Valve		Size / weight	G1 / 0.7 kg	
	Brass + Butadiene rubber	SIHI-Part No.	20 044 637	
	Brass + Teflon		20 044 639	
	1.4571 + Teflon		20 072 807	

Any changes in the interest of the technical development are reserved.

Sterling SIHI GmbH

Lindenstraße 170, D-25524 Itzehoe, Germany
Telephone +49 (0) 48 21 / 7 71-01, Fax +49 (0) 48 21 / 7 71-274
www.sihi.com