

SIHI^{dry} H1000

GENERAL TECHNICAL DATA

Suction capacity	1000 m³/h
Final pressure	< 0,1 mbar abs
Gas outlet temperature	200°C
Power consumption at final pressure	18 kW
Purge gas consumption	max. 20 NI/min
Cooling Water T_{min}	+ 10°C
Cooling Water T_{max}	+ 35°C
Sound level	< 74 dB(A)
Weight	ca. 580 kg

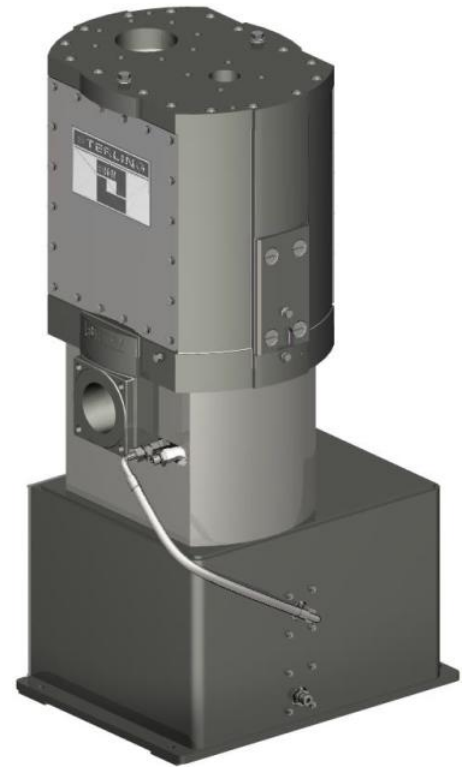

CONSTRUCTION

The compact system **SIHI^{dry} H1000** is a dry running, screw-spindle pump. The screw shaped rotors counter rotate without contact. The pump inlet is at the top and the outlet at the bottom. This gives top-down pumping for self-draining.

In contrast to conventional machines, both spindles are synchronised electronically and do not need a mechanical gearbox.

This innovative drive concept provides the foundation for allowing the basic unit to be transformed into more intelligent versions for integration within any process control system. This intelligent version of the **SIHI^{dry} H1000** is able to operate system attributes such as reactor pressure; valve functionality, etc. The data can also be stored and downloaded in order to ensure a maximum of process safety.

DESIGN

The **SIHI^{dry} H1000** vacuum system is available with Ex-Protection for the use in hazardous areas. The versatility of the modular unit allows it to be adapted to any process. Comprising casing and internal screw cooling in its basic form, the machine provides optimum temperature control in order to guard against condensation, corrosion, solvent ignition, etc.

Further temperature control is available with direct gas cooling in order to reduce vapour saturation conditions inside of the pumping chamber.

The drive control protects the machine during times of upset process conditions. Damage due to liquid carry-over is avoided by automatic speed regulation. Once the liquid has been pumped away by the machine, it will return to the required speed.

PROPERTIES

- No oil lubrication or service liquid
- Neither gear box nor transmission fluid
- No mechanical shaft seals
- Rapid dismantling for on-site maintenance
- Pressure resistant casing (test 16 bar)
- Electronic drive without wearing parts
- Process data recording & fault diagnosis
- Accurate and stable temperature profile with inner rotor cooling

Characteristic

Every operating point below the given characteristic curve is possible with the drive variant **DYNAMIC** by the input of the speed set point.

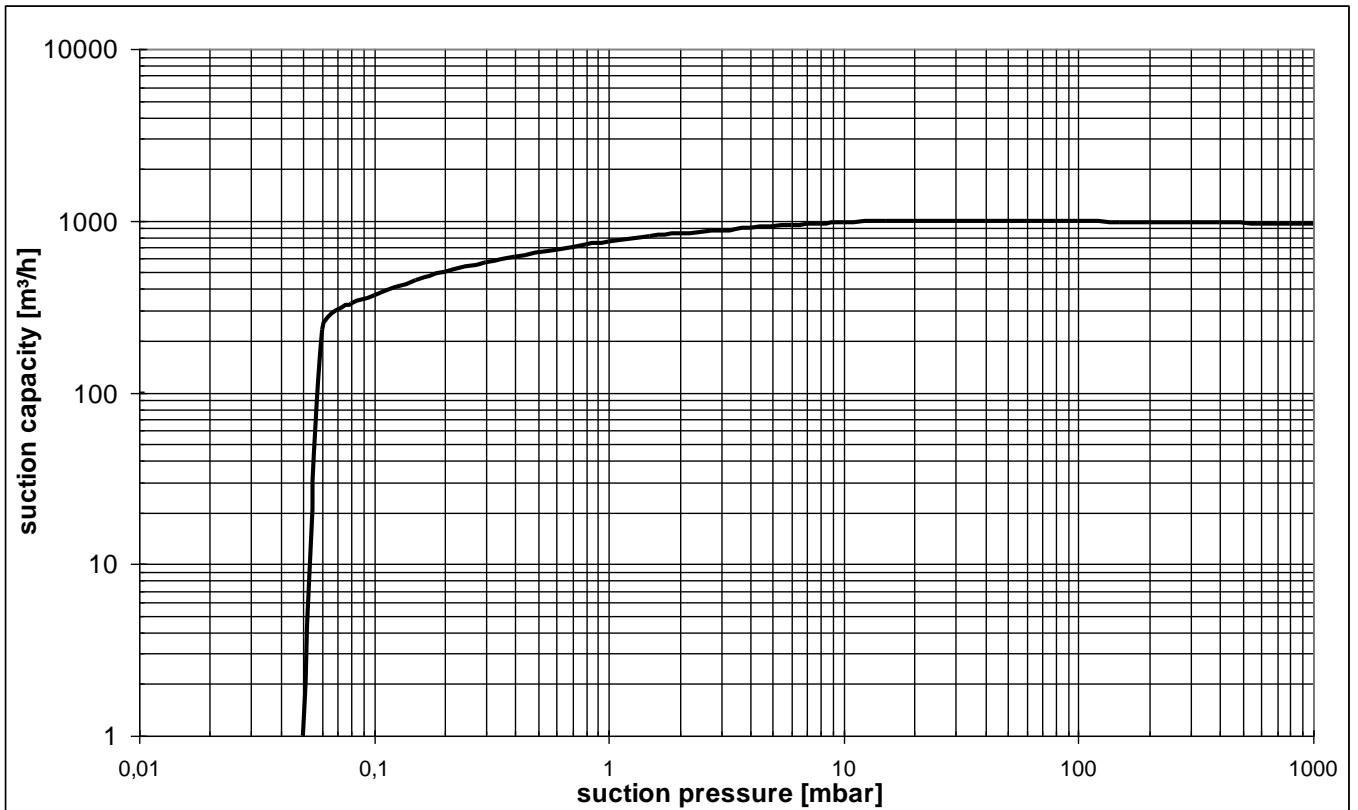

Sectional drawing

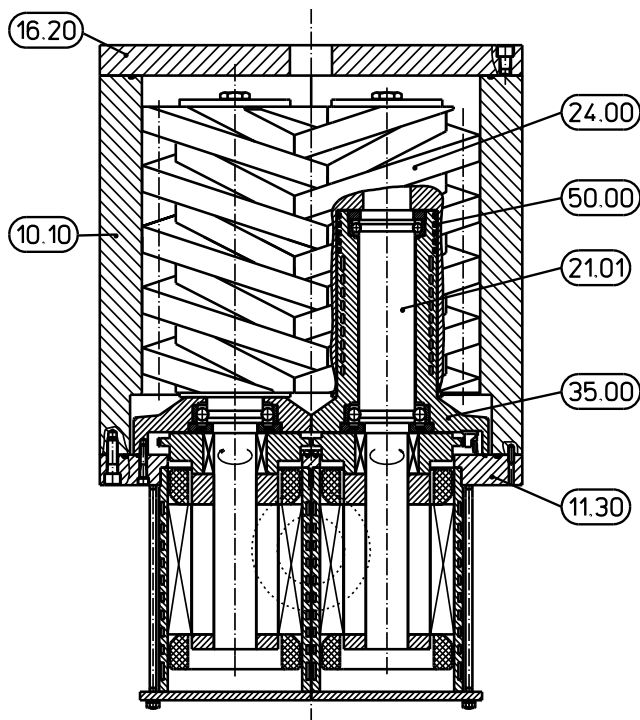

Materials

Item	Construction part	Material
10.10	Casing	EN-GJS-400-18-LT (GGG 40.3)
11.30	Intermediate plate	EN-GJS-400-18-LT (GGG 40.3)
16.20	Casing cover	1.0553
24.00	Twin screw spindle	1.4122
21.01	Shaft	1.4122
35.00	Bearing cartridge	1.4122
50.00	Shielding gas throttle	EN-GJL-250 (GG 25)

COOLING MECHANISMS

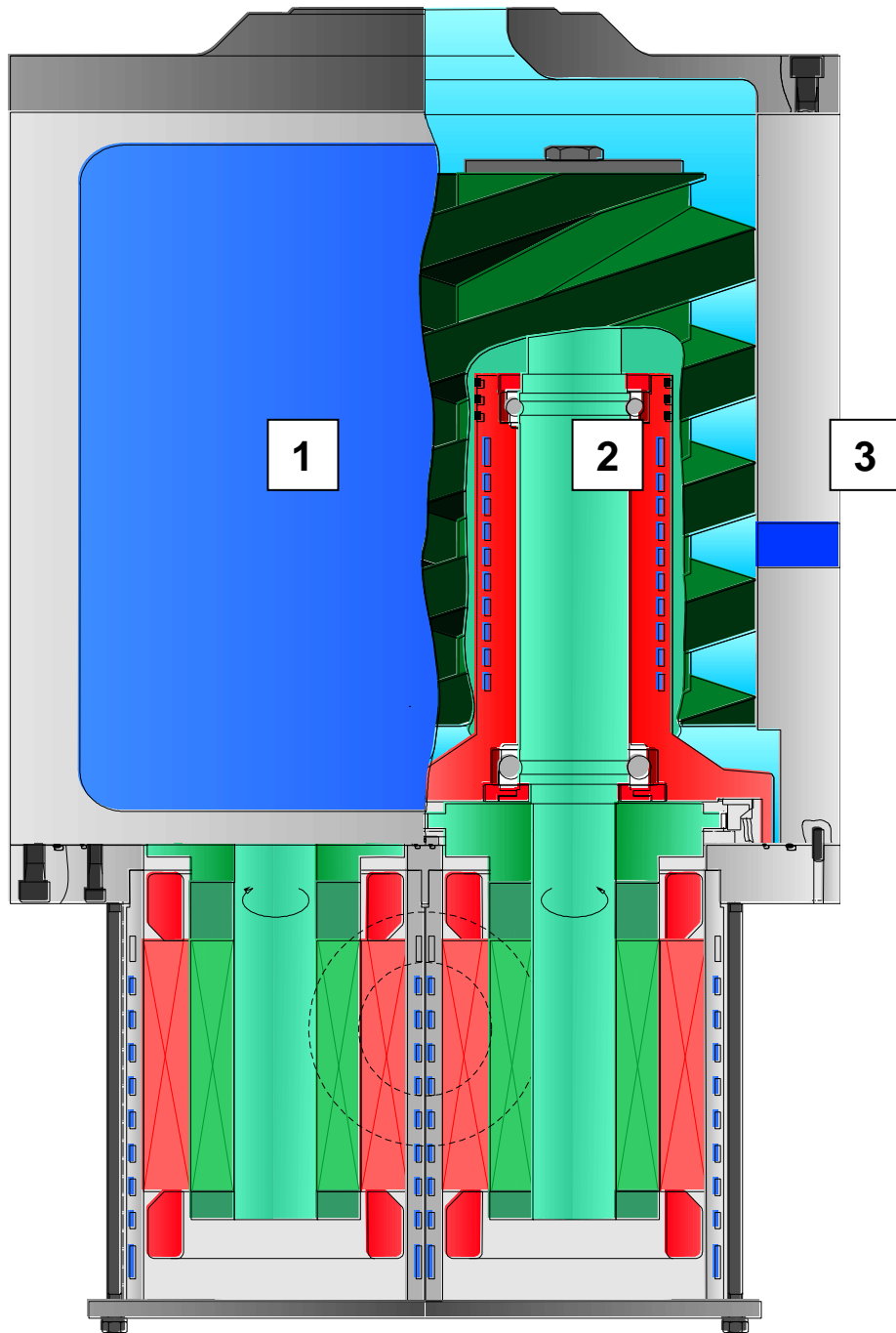

The actual gas temperatures will vary with the specific process and media:

1

Casing – basic liquid cooling within jacket:
Basic heat removal

2

Screws – internal liquid cooling
This permits lower temperatures within the vacuum chamber

3

Direct gas cooling (optional)
To avoid solids from accumulating within the vacuum pump

Scope of supply

The scope of supply for the basic design of the compact vacuum system incorporates **SIHI^{dry}** with the casing sealing made out of FEP and the following system components:

- drive electronics mounted in the connecting casing
- integrated motors
- cooling water circuit for cooling of the drive motors and screws as well as the pump casing
- suction sieve to prevent ingress of particles into the working chamber

Variants of drive control

BASIC

includes:

- **Fixed speed**
- Serial interface for service

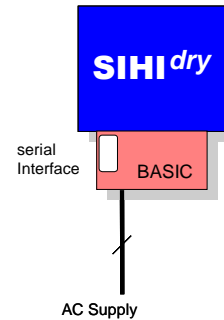

DYNAMIC

For the adaptation of the pumping speed to the actual demand

Includes:

- **Variable speed**
- **All signals via PROFIBUS DP**
- Input: Start/stop
- Input: Reset of failure
- Analogue input: Set value
- Output: operation/failure
- Serial interface for service

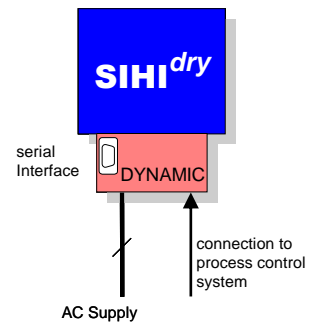

CONTROL

The drive variant **CONTROL** includes the automatic adaptation of the speed to the set point pressure value and thus enables an optimum regulation of the vacuum. Furthermore the drive variant **CONTROL** offers the automatic valve control and the appertaining logics for process-specific functions e.g. cleaning, standby etc.

Following signals from/to the DCS are available:

- **All signals via PROFIBUS DP**
- Signal inputs (start, stop, vacuum operation, cleaning)
- Set points (pressure or speed)
- Status signals (operation, vacuum operation, cleaning mode, no failure, warning, failure)
- Signal outputs (torque, speed and if required: suction pressure, temperature)

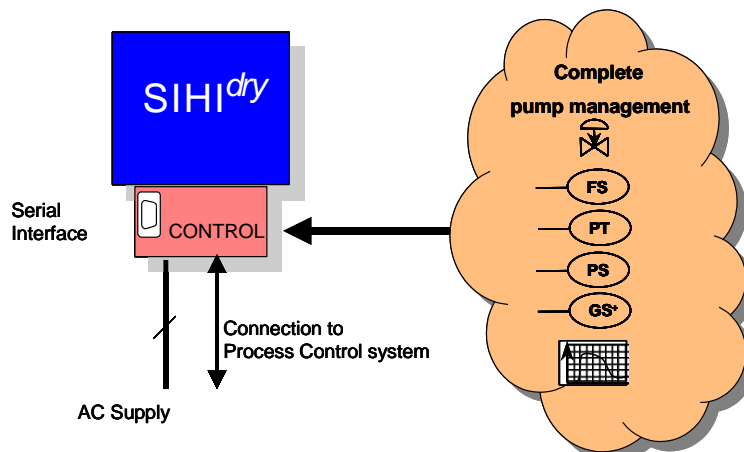

OPTIONAL ACCESSORIES

Module purge gas Ex

The standard EEx p gas system regulates, controls, and monitors the N₂ pressure at the shaft seal. It is completely integrated within the **SIHI^{dry}** System and permits pump installation within a hazardous area according to the ATEX – directive.

Module secondary cooling water circuit

Complete with circulating pump, flow indicator, thermostatic control valve, and heat exchanger; this extensive option is fully integrated into the base-plate. It is particularly useful in areas where site cooling water feed and return lines have very low differential pressures, and is normally very poor quality. Closed loop cooling allows the flow to be accurately regulated for an independent adjustment of the working chamber temperature.

Module suction valve

This module allows the pump to be isolated from the process at desired times by means of a pneumatic valve. This prevents process (residual) media from getting into the pump during times of stand-still. Control of this valve can be undertaken with the **CONTROL** Drive variant.

Module discharge valve

This module isolates the **SIHI^{dry}** at the discharge side from down-stream flow by means of a pneumatic valve. Reverse flow from the exhaust side is prevented. Also, it reduces the possibility of exhaust gasses entering the machine from common discharge manifolds. Control of this valve can be undertaken with the **CONTROL** Drive variant.

Module clean in process

Suited to processes that employ polymerisation, sublimation, or basically sticky substances. This module provides the correct valve combination for clean-in-place, and also N₂ flush in order to inertise the pump for periods of standstill. Control of these valves can be undertaken with the **CONTROL** Drive variant.

Module direct gas cooling

This system is ideally suited to processes that involve thermally sensitive media that can degrade or polymerise at high temperatures. It takes a small amount of exhaust gas from the pump, passes it through a compact heat exchanger/condenser, and back into the pump. The cooled, dry gas is injected back into the later stages of the compression cycle thereby not detrimentally hindering the suction capacity. This avoids deposition of thermally sensitive media by ensuring that there is an adequate flow rate throughout the pump, even at low pressures.

Module temperature measurement

This module allows the measurement of different temperatures by means of integrated defined temperature sensors.

Module pressure measurement

This module allows the measurement of different process pressures within the vacuum system. This module is fully integrated into the **SIHI^{dry}** when drive variant **CONTROL** is used.

Module operator indicator panel

To monitor and control the vacuum system within a hazardous area. The local 5,25" display provides the operator with a visual indication of all necessary pump parameters. All necessary operating states can be set by a touch panel menu.

FLOW DIAGRAM

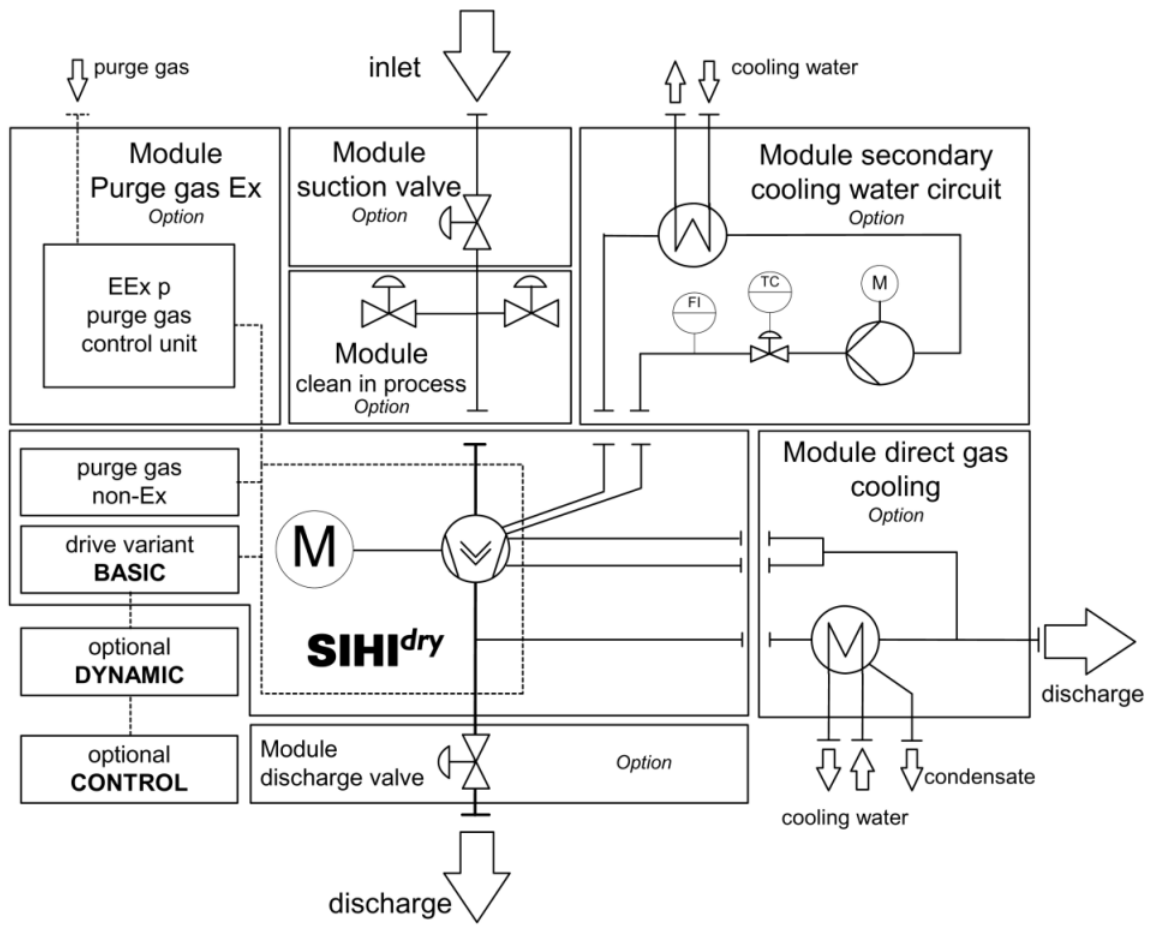

Dimensions

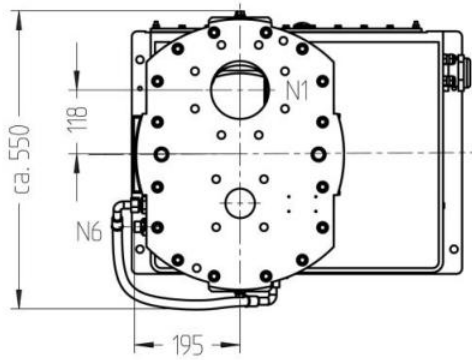
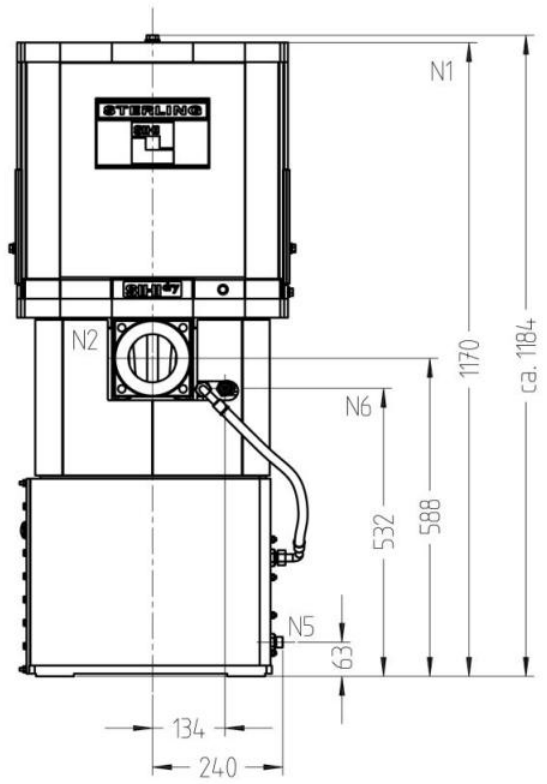
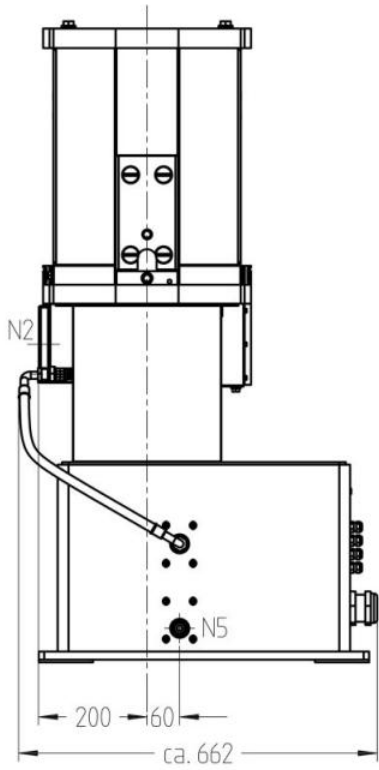

	Item	DN	PN	Connection
N1	Inlet	100	16	8 x M16
N2	Outlet	80	16	4 x M16
N5	Coolant inlet	-	-	G ½" External screw thread
N6	Coolant outlet	-	-	G ½" External screw thread

Subject to change without prior notice.

