

SIHI^{dry} H250

GENERAL TECHNICAL DATA

Suction capacity	290 m³/h
Final pressure	< 0,1 mbar abs
Gas outlet temperature	135 °C
Power consumption at final pressure	5 kW
Purge gas consumption	max. 20 NI/min
Cooling Water T_{min}	+ 10°C
Cooling Water T_{max}	+ 35°C
Sound level	< 63 dB(A)
Weight	ca. 580 kg



CONSTRUCTION

The compact system **SIHI^{dry} H250** is a dry running, screw-spindle pump. The screw shaped rotors counter rotate without contact. The pump inlet is at the top and the outlet at the bottom. This gives top-down pumping for self-draining.

In contrast to conventional machines, both spindles are synchronised electronically and do not need a mechanical gearbox.

This innovative drive concept provides the foundation for allowing the basic unit to be transformed into more intelligent versions for integration within any process control system. This intelligent version of the **SIHI^{dry} H250** is able to operate system attributes such as reactor pressure; valve functionality, etc. The data can also be stored and downloaded in order to facilitate good manufacturing practice.

DESIGN

The **SIHI^{dry} H250** vacuum system is available with Ex-Protection for the use in both hazardous and non-hazardous areas.

The versatility of the modular unit allows it to be adapted to any process.

Comprising casing and internal screw cooling in its basic form, the machine provides optimum temperature control in order to guard against condensation, corrosion, polymerisation, solvent ignition, etc.

Further temperature control is available with direct gas cooling in order to reduce vapour saturation conditions inside of the pumping chamber.

The drive control protects the machine during times of upset process conditions. Damage due to liquid carry-over is avoided by automatic speed regulation. Once the liquid has been pumped away by the machine, it will return to the required speed.

PROPERTIES

- No oil lubrication or service liquid
- Neither gear box nor transmission fluid
- No mechanical shaft seals
- Rapid dismantling for on-site maintenance
- Pressure resistant casing (test 16 bar)
- Electronic drive without wearing parts
- Process data recording & fault diagnosis
- Accurate and stable temperature profile with inner rotor cooling

Characteristic

Every operating point below the given characteristic curve is possible with the drive variant **DYNAMIC** by the input of the speed set point.

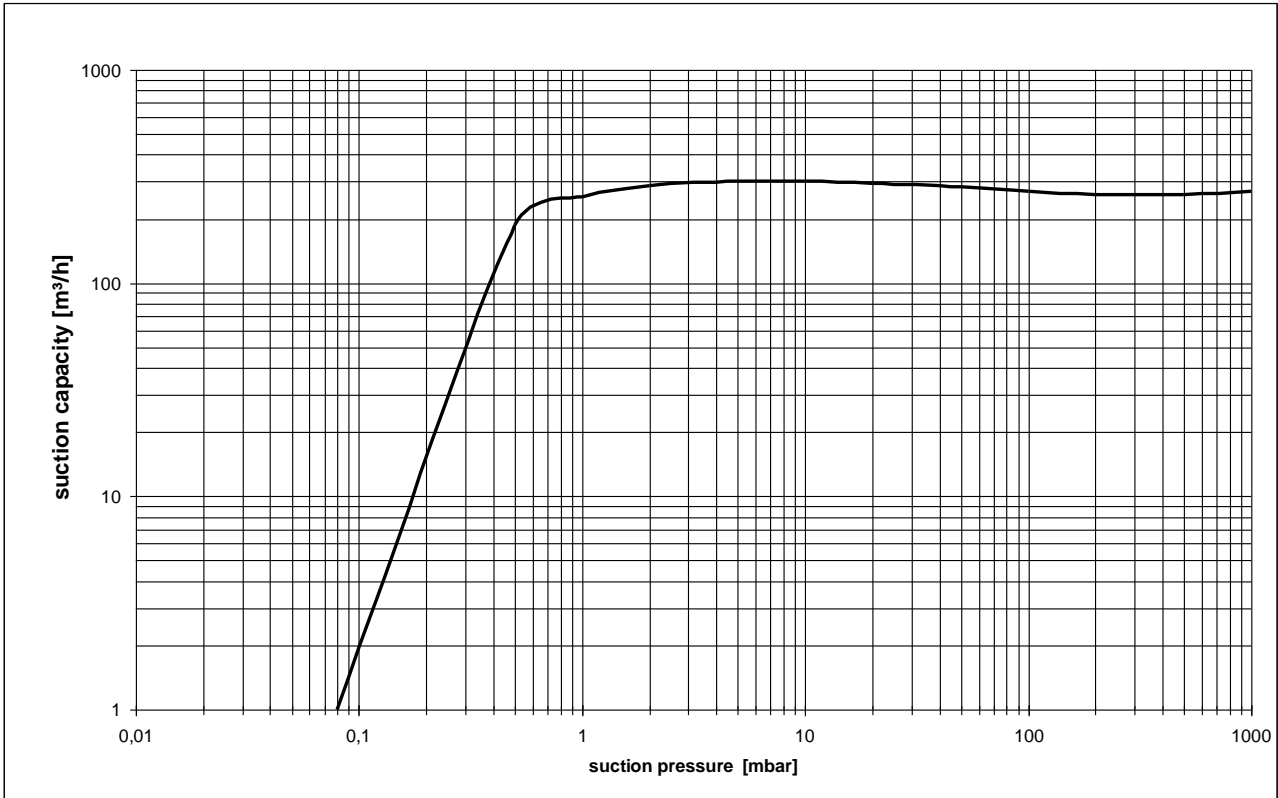

Sectional drawing

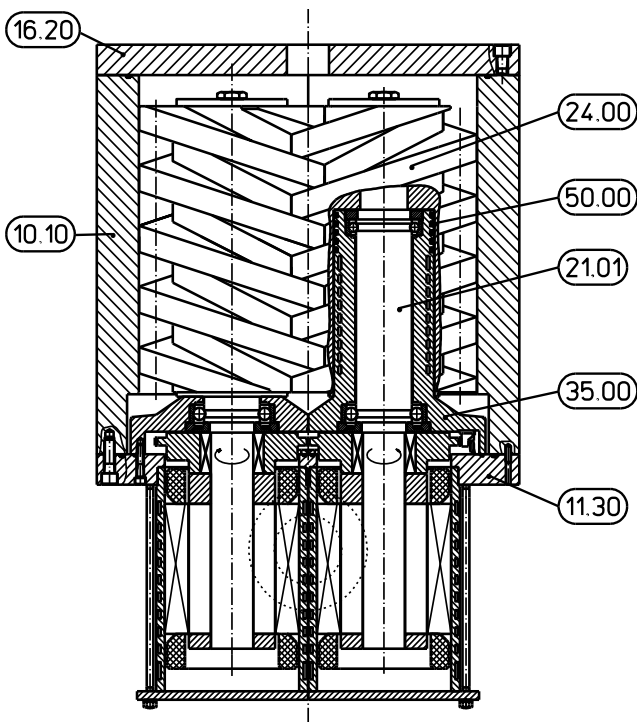

Materials

Item	Construction part	Material
10.10	Casing	EN-GJS-400-18-LT (GGG 40.3)
11.30	Intermediate plate	EN-GJS-400-18-LT (GGG 40.3)
16.20	Casing cover	1.0553
24.00	Twin screw spindle	1.4122
21.01	Shaft	1.4122
35.00	Bearing cartridge	1.4122
50.00	Shielding gas throttle	EN-GJL-250 (GG 25)

COOLING MECHANISMS

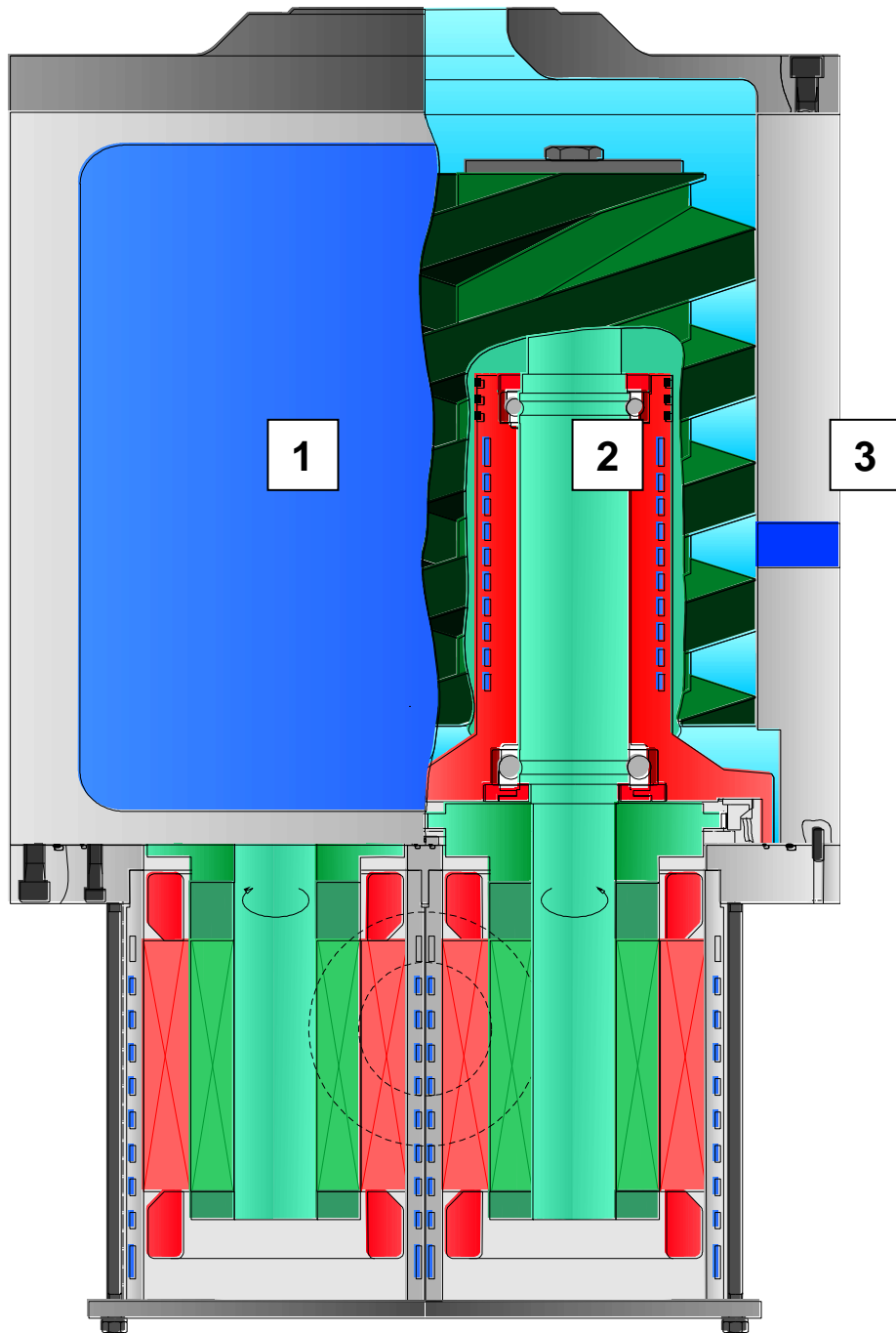

The actual gas temperatures will vary with the specific process and media:

1

Casing – basic liquid cooling within jacket:
Basic heat removal

2

Screws – internal liquid cooling
This permits lower temperatures within the vacuum chamber

3

Direct gas cooling (optional)
To avoid solids from accumulating within the vacuum pump

SCOPE OF SUPPLY

The basic design of **SIHI^{dry}** incorporates static FEP O-Ring type casing seals along with the following components:

- Drive electronics fitted in the connecting casing
- Cooling water circuit for cooling of the pump casing, drive motors, and twin-screws
- Suction strainer in order to avoid detrimental particle ingress into the pump.

VARIATION IN DRIVE CONTROL

BASIC

Includes:

- **Fixed speed**
- Input: start/stop
- Input: reset of failure
- Output: operation/failure
- Serial interface

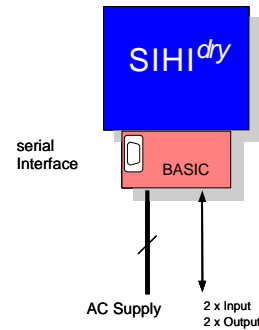

DYNAMIC

For the adaptation of the suction capacity to the actual requirement.

Includes:

- **Variable speed**
- Input: start/stop
- Input: reset of failure
- Analogue input: set value
- Output: operation/failure
- Serial interface

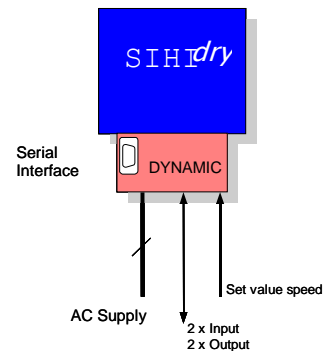

CONTROL

Fully integrated into the system, this control provides some essential process and operating features. These include: Warm up cycles; vacuum switching on/off; flushing for clean in place; N2 purging; and other external trips that can be hard wired into the system such as level and/or temperature gauges, etc. Importantly, the control does not require any further programming nor logic by the customer.

Moreover a vacuum regulation can be realised.

Following signals from/to the DCS are available:

- Digital status signals (vacuum operation, warning, stand-by, emergency stop, if necessary cleaning)
- Analogue signals (torque, speed, and, if necessary the suction pressure and different temperatures)
- Digital set points (start, stop, vacuum operation, and, if necessary cleaning)
- Analogue set points (pressure, speed)

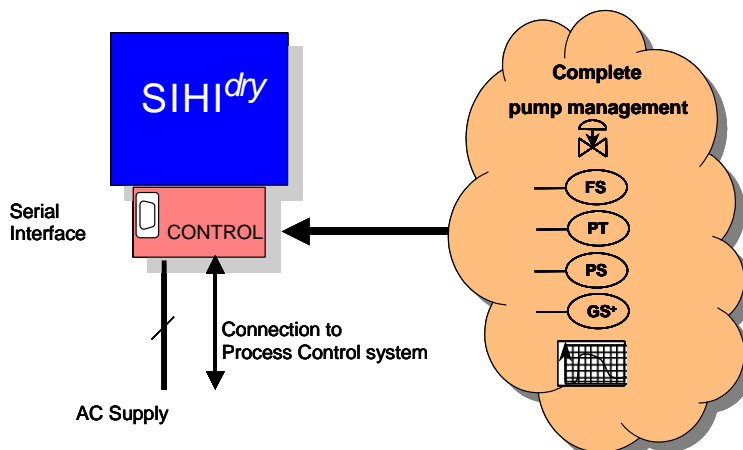

OPTIONAL ACCESSORIES

Module purge gas Ex

The standard EEx p gas system regulates, controls, and monitors the N₂ pressure at the shaft seal. It is completely integrated within the **SIHI^{dry}** System and permits pump installation within a hazardous area according to the ATEX – directive.

Module secondary cooling water circuit

Complete with circulating pump, flow indicator, thermostatic control valve, and heat exchanger; this extensive option is fully integrated into the base-plate. It is particularly useful in areas where site cooling water feed and return lines have very low differential pressures, and is normally very poor quality. Closed loop cooling allows the flow to be accurately regulated for an independent adjustment of the working chamber temperature.

Module suction valve

This module allows the pump to be isolated from the process at desired times by means of a pneumatic valve. This prevents process (residual) media from getting into the pump during times of stand-still. Control of this valve can be undertaken with the **CONTROL** Drive variant.

Module discharge valve

This module isolates the **SIHI^{dry}** at the discharge side from down-stream flow by means of a pneumatic valve. Reverse flow from the exhaust side is prevented. Also, it reduces the possibility of exhaust gasses entering the machine from common discharge manifolds.

Control of this valve can be undertaken with the **CONTROL** Drive variant.

Module clean in process

Suited to processes that employ polymerisation, sublimation, or basically sticky substances. This module provides the correct valve combination for clean-in-place, and also N₂ flush in order to inertise the pump for periods of standstill. Control of these valves can be undertaken with the **CONTROL** Drive variant.

Module direct gas cooling

This system is ideally suited to processes that involve thermally sensitive media that can degrade or polymerise at high temperatures. It takes a small amount of exhaust gas from the pump, passes it through a compact heat exchanger/condenser, and back into the pump. The cooled, dry gas is injected back into the later stages of the compression cycle thereby not detrimentally hindering the suction capacity. This avoids deposition of thermally sensitive media by ensuring that there is an adequate flow rate throughout the pump, even at low pressures.

Module temperature measurement

This module allows the measurement of different temperatures by means of integrated defined temperature sensors.

Module pressure measurement

This module allows the measurement of different process pressures within the vacuum system. This module is fully integrated into the **SIHI^{dry}** when drive variant **CONTROL** is used.

Module operator indicator panel

To monitor and control the vacuum system within a hazardous area.
 The local 5,25" display provides the operator with a visual indication of all necessary pump parameters.
 All necessary operating states can be set by a touch panel menu.

PARA^{dry} Parameter Modification Module

Eliminating the need to employ PLC programmers, the **PARA^{dry}** software enables the principle process engineer to modify specific pump parameters. Such parameters are at the discretion of the customer and may include max/min temperature boundaries, speed and pressure, settings, warm up cycles, etc. providing long term future running adaptability, a standard windows based computer is needed.

FLOW DIAGRAM

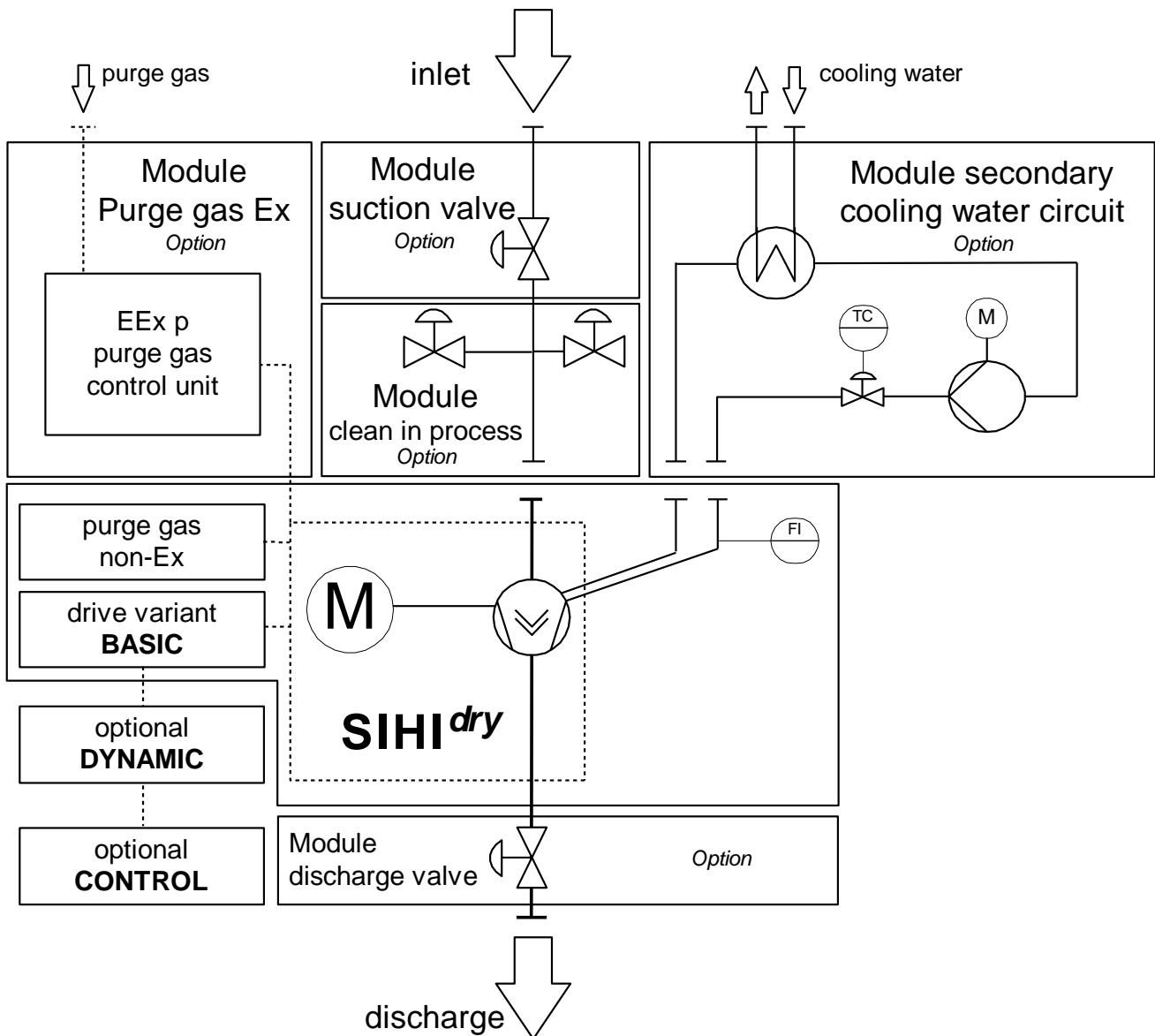

Dimensions

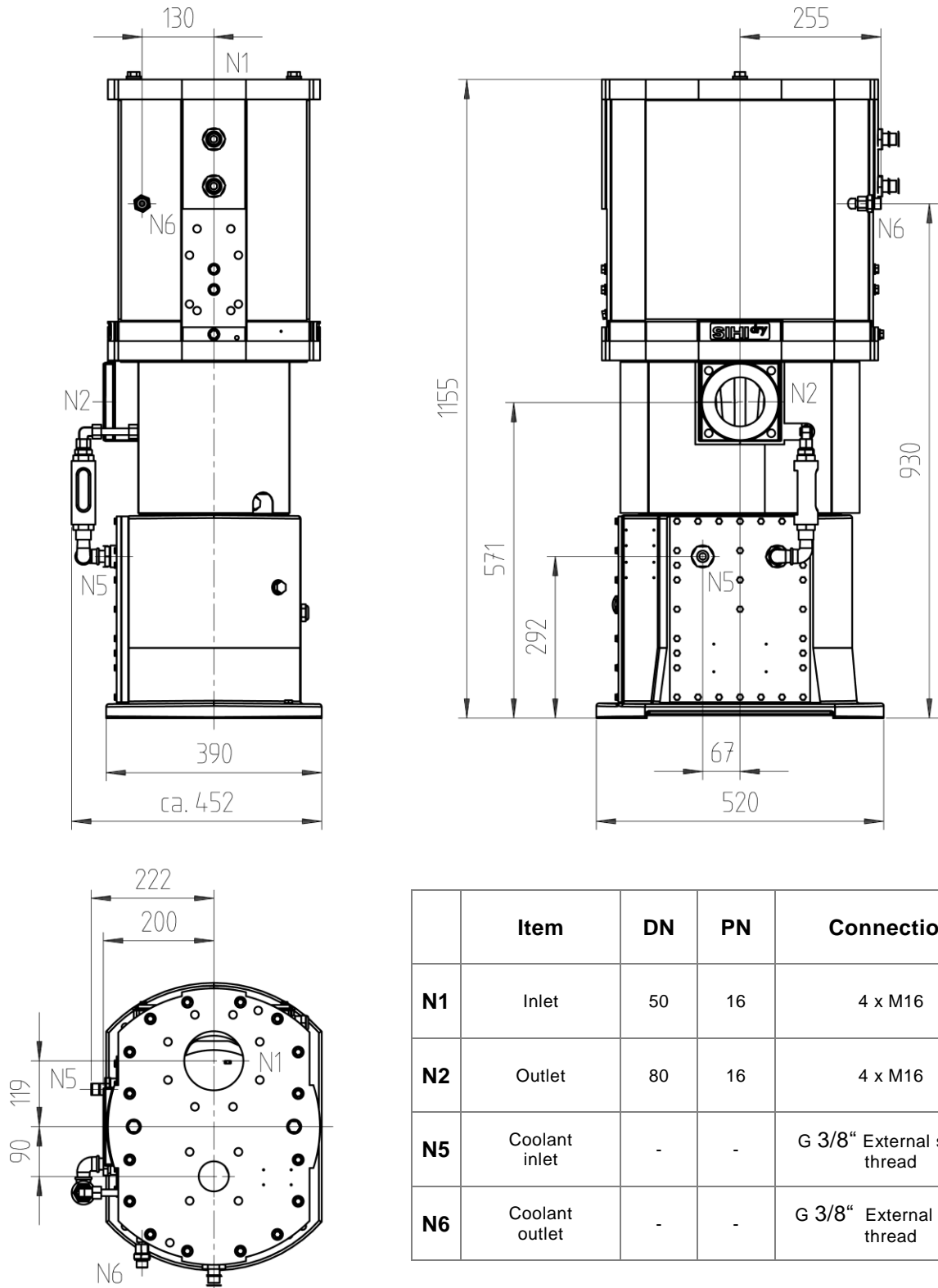

	Item	DN	PN	Connection
N1	Inlet	50	16	4 x M16
N2	Outlet	80	16	4 x M16
N5	Coolant inlet	-	-	G 3/8" External screw thread
N6	Coolant outlet	-	-	G 3/8" External screw thread

Subject to change without prior notice.

