

SIHI^{dry} S630

GENERAL TECHNICAL DATA

Suction capacity	600 m ³ /h
Final pressure	< 0,01 mbar abs
Power consumption at final pressure	10 kW
Cooling Water T _{min}	+ 10°C
Cooling Water T _{max}	+ 35°C
Sound level	< 70 dB(A)
Weight	ca. 580 kg

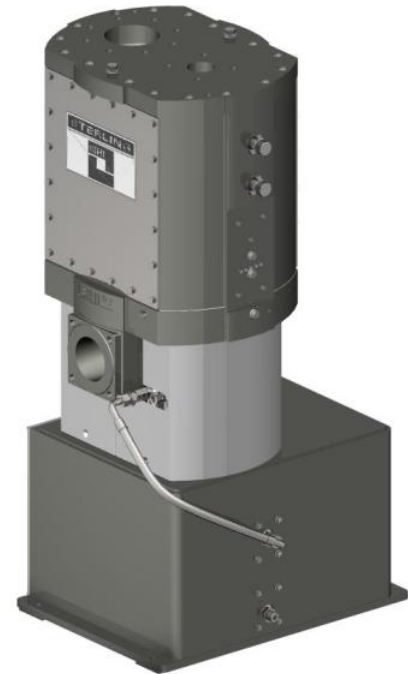

CONSTRUCTION

The vacuum system **SIHI^{dry} S630** has been especially developed for use in industrial applications. It is based upon a dry running twin screw principle, which is without any lubricants, sealants or operating liquids.

Wide clearances in the pumping chamber make the pump robust when it comes to the handling of particles and liquids. It is supported by top-down pumping (inlet at the top and the outlet at the lowest point in the pumping chamber) and the pump chamber has been designed to eliminate dead space.

The cantilever drive shaft arrangement allows the pump casing to be easily assembled without removing the bearing. If the pump chamber needs to be cleaned then it can be carried out on site by the operator's own personnel.

The labyrinth shaft seals operate without contact and are therefore wear free.

In contrast to conventional pumps both screw spindles are electronically synchronised rather than by mechanical means.

This innovative drive means that monitoring and filling of gear oil is not required and the drive design results in the vacuum pump being extremely quiet.

DESIGN

The flexibility of the modular system allows it to adapt to any process conditions. Thus the innovative drive concept and its optional additional features, such as the regulation of the speed to meet the requirement of the system, offers the possibility to considerably reduce the power absorption.

At the same time if it is necessary to control the valves for the purging of the pump, this can be done by the vacuum system itself. Furthermore the intelligent system offers the possibility to accurately monitor the important process data. This is to ensure safety is maximised and to recognise any deviations in good time so as to take appropriate counter measures.

PROPERTIES

No gear or transmission lubricant, neither in the pumping chamber nor in the gear

Problem-free handling of particles and liquids

Rapid disassembly of the pump chamber without removing the bearing.

Shaft seals are contact free & wear free

Silent electronic drive

Possibility of error detection with remote data transmission

Characteristic

Every operating point below the given characteristic curve is possible with the drive variant **DYNAMIC** by the input of the speed set point.

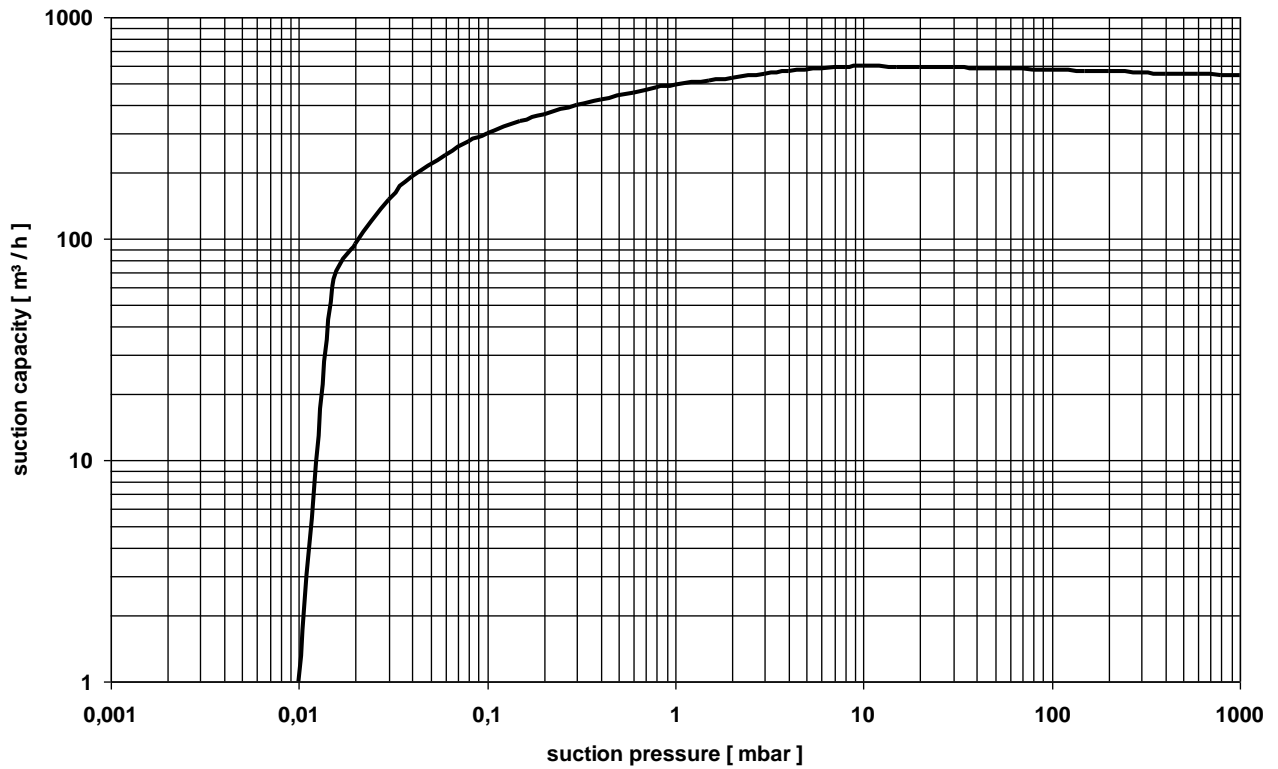

Sectional drawing

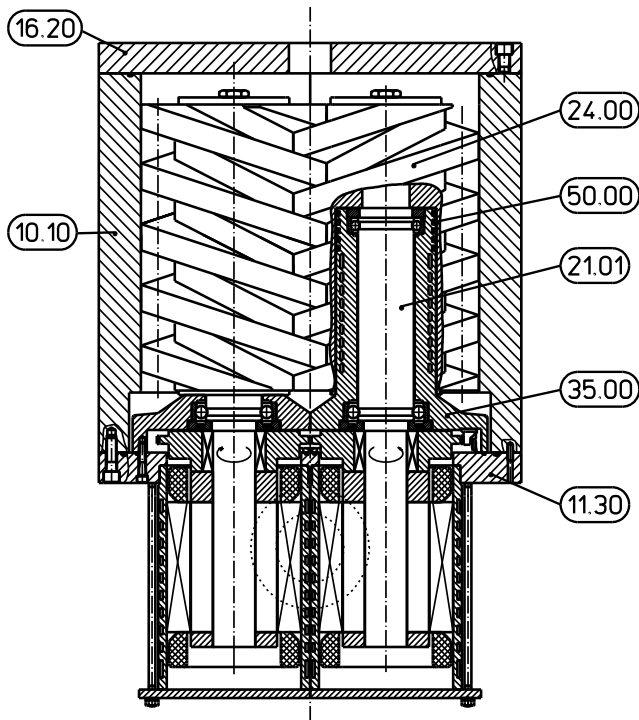

Materials

Item	Construction part	Material
10.10	Casing	EN-GJS-400-18-LT (GGG 40.3)
11.30	Intermediate plate	EN-GJS-400-18-LT (GGG 40.3)
16.20	Casing cover	1.0553
24.00	Twin screw spindle	1.4122
21.01	Shaft	1.4122
35.00	Bearing cartridge	1.4122
50.00	Shielding gas throttle	EN-GJL-250 (GG 25)

COOLING MECHANISMS

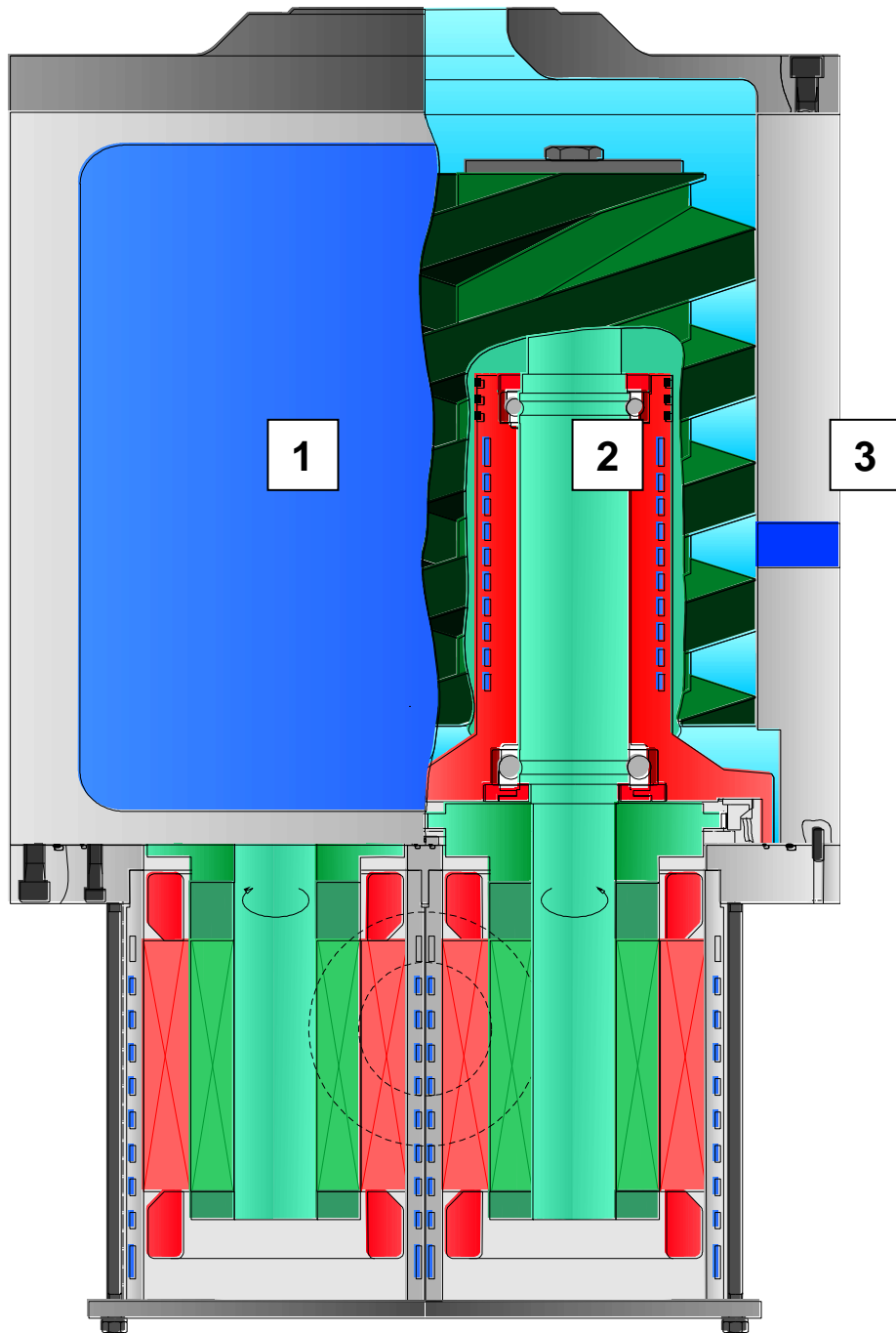

The actual gas temperatures will vary with the specific process and media:

1

Casing – basic liquid cooling within jacket:

Basic heat removal

2

Screws – internal liquid cooling

This permits lower temperatures within the vacuum chamber

3

Direct gas cooling (optional)

To avoid solids from accumulating within the vacuum pump

Scope of supply

The scope of supply for the basic design of the compact vacuum system incorporates **SIHI^{dry}** with the casing sealing made out of Viton and the following system components:

- drive electronics mounted in the connecting casing
- integrated motors
- cooling water circuit for cooling of the drive motors and screws as well as the pump casing

Variants of drive control

BASIC

includes:

- **Fixed speed**
- Serial interface for service

DYNAMIC

For the adaptation of the pumping speed to the actual demand

Includes:

- **Variable speed**
- **All signals via PROFIBUS DP**
- Input: Start/stop
- Input: Reset of failure
- Analogue input: Set value
- Output: operation/failure
- Serial interface for service

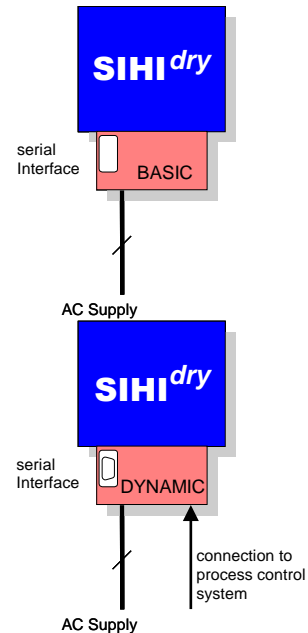

CONTROL

The drive variant **CONTROL** includes the automatic adaptation of the speed to the set point pressure value and thus enables an optimum regulation of the vacuum. Furthermore the drive variant **CONTROL** offers the automatic valve control and the appertaining logics for process-specific functions e.g. cleaning, standby etc.

Following signals from/to the DCS are available:

- **All signals via PROFIBUS DP**
- Signal inputs (start, stop, vacuum operation, cleaning)
- Set points (pressure or speed)
- Status signals (operation, vacuum operation, cleaning mode, no failure, warning, failure)
- Signal outputs (torque, speed and if required: suction pressure, temperature)

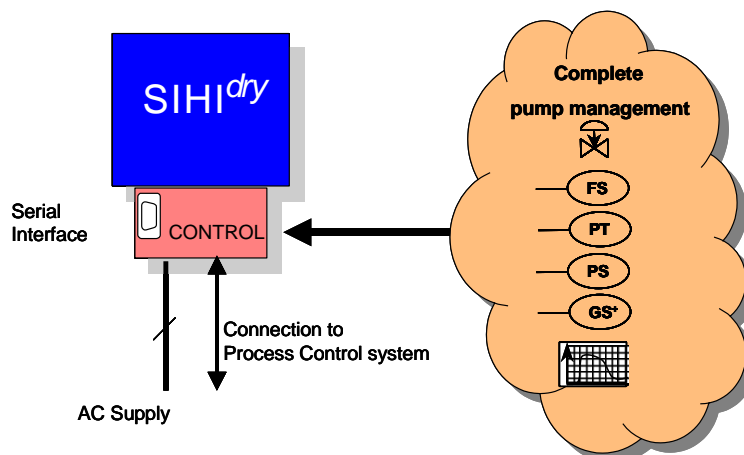

OPTIONAL ACCESSORIES

Module secondary cooling water circuit

Complete with circulating pump, thermostatic control valve, and heat exchanger; this extensive option is fully integrated into the base-plate. It is particularly useful in areas where site cooling water feed and return lines have very low differential pressures, and is normally very poor quality. Closed loop cooling allows the flow to be accurately regulated for an independent adjustment of the working chamber temperature.

Module suction valve

This module allows the pump to be isolated from the process at desired times by means of a pneumatic valve. This prevents process (residual) media from getting into the pump during times of stand-still. Control of this valve can be undertaken with the **CONTROL** Drive variant.

Module discharge valve

This module isolates the **SIHI^{dry}** at the discharge side from down-stream flow by means of a pneumatic valve. Reverse flow from the exhaust side is prevented. Also, it reduces the possibility of exhaust gasses entering the machine from common discharge manifolds.

Control of this valve can be undertaken with the **CONTROL** Drive variant.

Module clean in process

Suited to processes that employ polymerisation, sublimation, or basically sticky substances. This module provides the correct valve combination for clean-in-place, and also N₂ flush in order to inertise the pump for periods of standstill. Control of these valves can be undertaken with the **CONTROL** Drive variant.

Module temperature measurement

This module allows the measurement of different temperatures by means of integrated defined temperature sensors.

Module pressure measurement

This module allows the measurement of different process pressures within the vacuum system.

This module is fully integrated into the **SIHI^{dry}** when drive variant **CONTROL** is used.

Module operator indicator panel

To monitor and control the vacuum system within a hazardous area.

The local 5,25" display provides the operator with a visual indication of all necessary pump parameters.

All necessary operating states can be set by a touch panel menu.

FLOW DIAGRAM

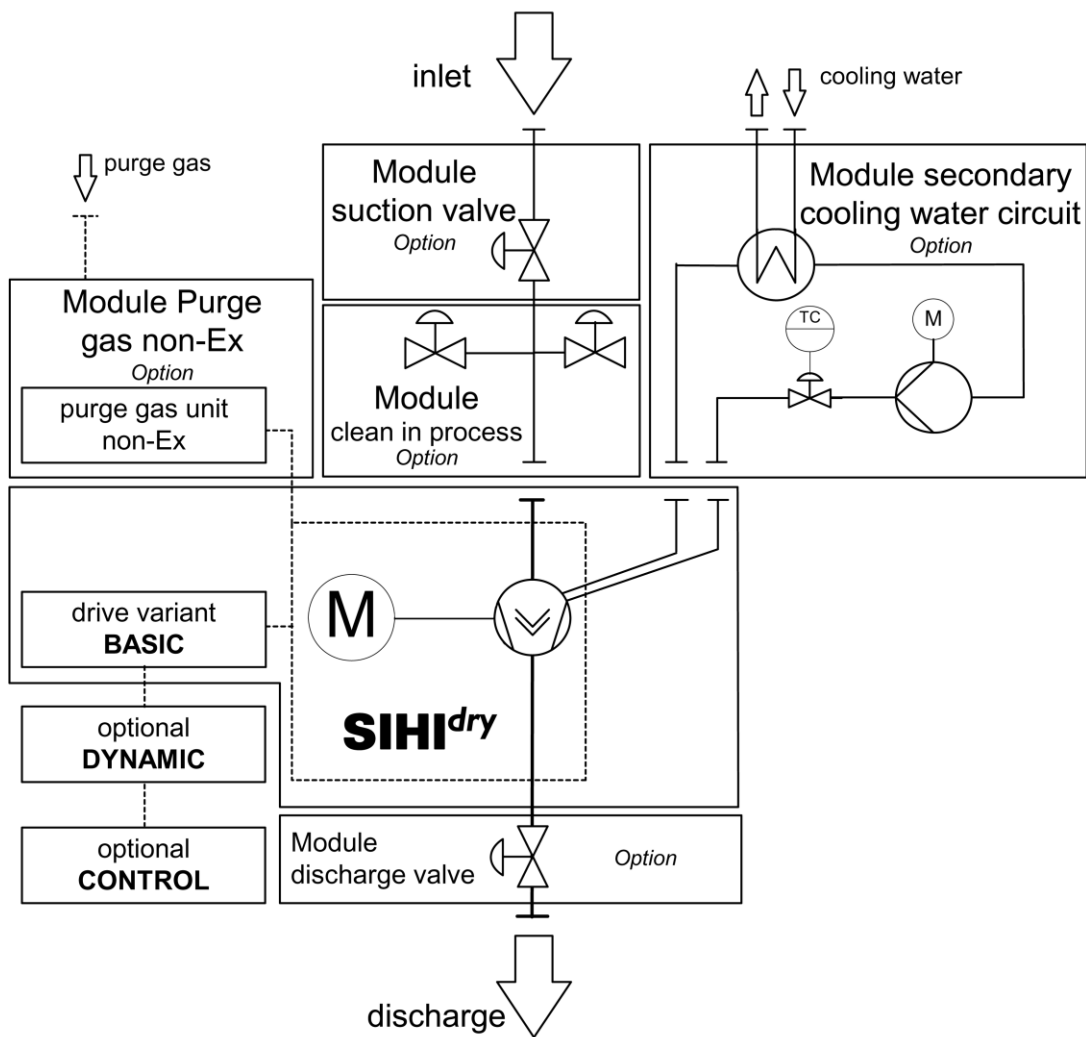

Dimensions

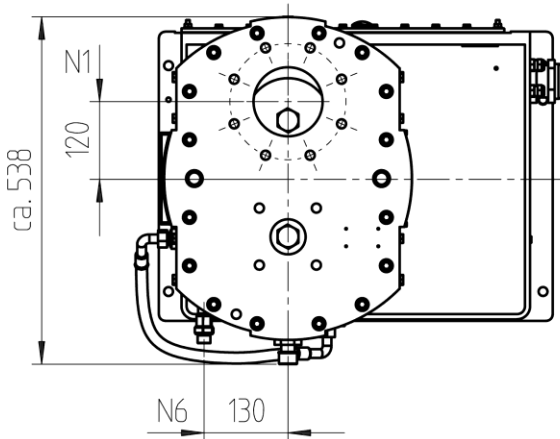
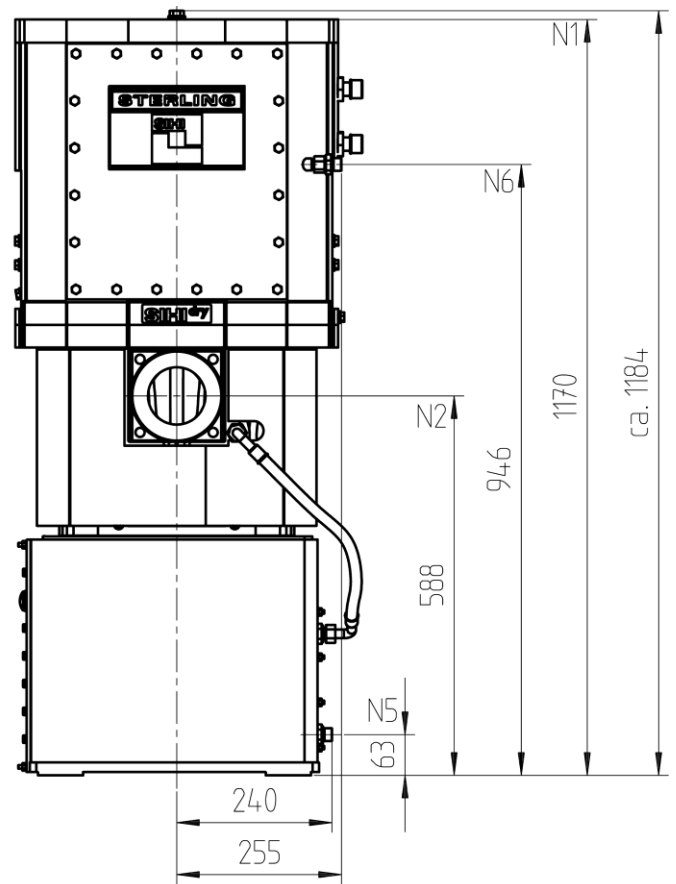
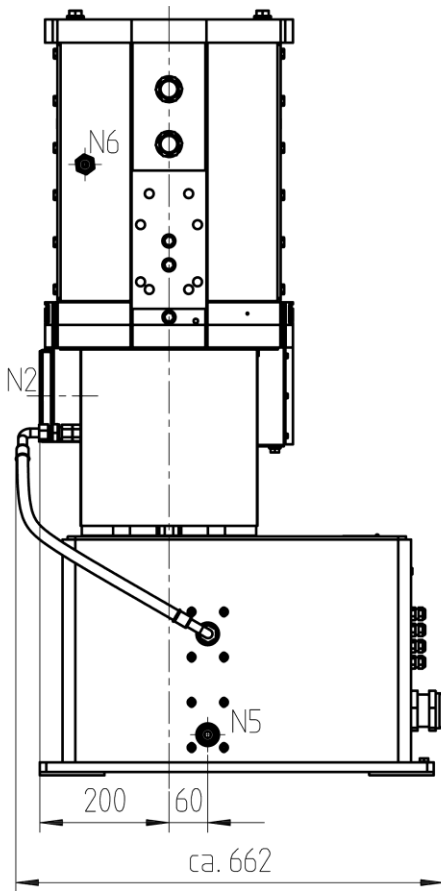

	Item	DN	PN	Connection
N1	Inlet	100	16	8 x M16
N2	Outlet	80	16	4 x M16
N5	Coolant inlet	-	-	G ½" External screw thread
N6	Coolant outlet	-	-	G ½" External screw thread

Subject to change without prior notice.

