



# Flygt top-entry agitators

CONVENIENT AND EFFICIENT

**FLYGT**  
a xylem brand

# Top energy-efficient performance



## Comprehensive mixing portfolio

Xylem's wide array of reliable, trouble-free mixing equipment includes;

- Flygt top-entry agitators
- Flygt low-speed mixers
- Flygt compact mixers
- Flygt jet mixers
- Flygt hydroejectors

## Rising to the mixing challenge

All mixing applications require varying degrees of both small-scale turbulence and bulk flow. With a good bulk flow, the contents of the entire tank are put into motion so that all parts are involved in the mixing. The strength of the bulk flow is, in turn, dependent on the total amount of installed thrust and layout.

## Unparalleled expertise, broad mixing solutions

Xylem pioneered the use of thrust as the main performance parameter for mixing. And every day, we put more than 50 years of R&D expertise and practical experience to work to determine the right technology, mixer size and installation for your requirements.

Our comprehensive portfolio of mixers and agitators cover virtually every requirement. Hundreds of thousands of Flygt mixers and agitators are in service worldwide, delivering efficient mixing performance.

## Top-entry agitation

When deep tank mixing is essential for wastewater treatment processes, Flygt top-entry agitators deliver outstanding cost-effective performance for applications that involve all types of fluids, including high DS fibrous sludge.

Engineered for energy efficiency, hygienic handling and ease of installation and service, these agitators combine dry-installed drives with submersible shaft and impellers for:

- Digester mixing
- Denitrification processes
- Sludge storage mixing



## Advantages of Flygt top-entry agitators

- Maximum uptime
- Strong bulk flow and high mixing efficiency
- High energy efficiency
- Easy to service
- Highly versatile for all fluid types
- Hygienic handling

# Higher process reliability, greater flexibility

**Ensuring successful mixing depends on the reliability and flexibility of the right mixing technology. With Flygt top-entry agitators from Xylem, you can effectively fine-tune your anaerobic, anoxic and digester processes regardless of tank depth, volume, shape or size.**

## Sturdy construction

Every component of Flygt top-entry mixers is engineered to withstand tens of thousands of hours of continuous operation. Parallel shaft geared motors combined with rigid drive shaft and specially designed impellers contribute to long-lasting operation.

## Outstanding impeller design

Whether you choose our standard three-blade hydrofoil impellers or our proven non-clogging Flygt banana blade impellers, you get exceptional thrust and high bulk flow along with excellent energy efficiency. Our signature yellow impeller blades with its backswept design, offers the advantage of self-cleaning properties to ensure clog-free operation, even in the presence of fibrous materials.

## Design flexibility for any requirement

Our top-entry agitator portfolio comprises three reliable Flygt models that can be tailored to your process needs. Simply tell us about your agitation requirements. Then let us recommend the configuration that is right for you by specifying the impeller type, number, size, shaft and position.

Built to fit: Configure your Flygt top-entry agitators with a single impeller or multiple impellers up to 4 meters in diameter.



Robust cast-iron bearing housing



All wetted parts made of high-alloy steel



Impeller designs for optimum performance in different fluids and/or tank types.



# Flygt 4850

## For a wide variety of mixing scenarios



**1 Detachable couplings with carrier pins**  
Easily withstand torsional forces.

**2 Parallel shaft geared motor**  
Ensures continuous duty and long lifespan.

**3 Robust bearing housing**  
Protects bearings to ensure smooth operation.

**4 Spherical roller bearings**  
Provide up to 100,000 hours of service life.

**5 Compact high-alloy shaft**  
Provides rigidity and load-bearing capabilities.

**6 Flygt banana blade impellers**  
Provide sustained mixing efficiency even in the presence of fibrous material. Permanently attached to the shaft in fixed positions.

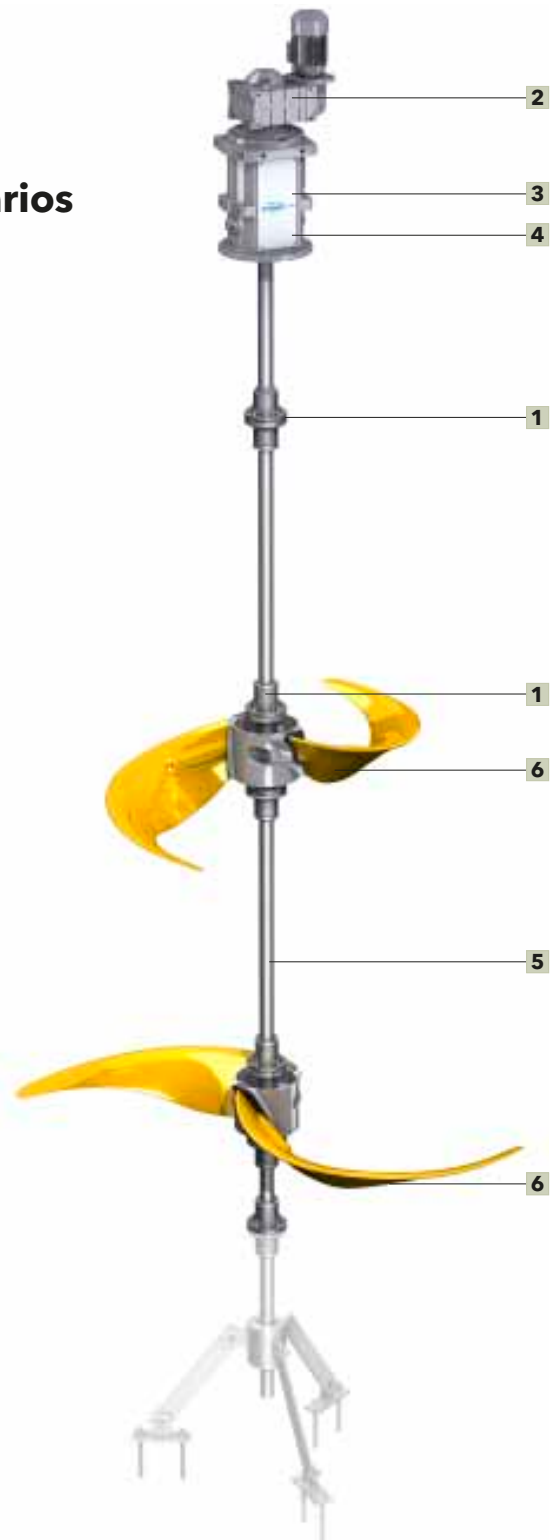

**Optional three-blade hydrofoil impeller**  
Adjustable positioning optimizes bulk flow and prevents formation of surface scum. Available in high-alloy steel for high temperatures with up to 2.5-m diameters. Locks to shaft by means of a tapered clamp.



**Bottom support bearing**  
This accessory securely affixes the shaft to the basin floor, eliminating agitator and bridge vibration to provide ultimate stability.

# Flygt 4860/4870

## For easy-to-service digester mixing

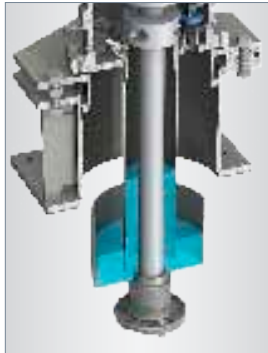

### 1 Wear-proof water lock

Prevents leakage of potentially harmful gases and agitator breakdown through the use of an explosion-proof gear motor and level sensor system. No wear parts.

### 2 Parallel shaft geared motor

Ensures continuous duty and long lifespan.

### 3 Robust bearing housing

Protects bearings to ensure smooth operation.

### 4 Long-life roller bearings

Provide long service life.

### Couplings with carrier pins

Easily withstand torsional forces. Stress relievers mitigate shearing forces on the shaft hub and

### 6 minimize the risk of blade damage.

### Leveling flange

Makes it easy to

### 7 adjust shaft to true vertical position.

### High-strength, variable-length shaft

Reinforced with plunge and carrier pins. Provides long service lifetime and minimizes the risk of breakdown.

### 8 Flygt three-blade hydrofoil impellers

### Flygt three-blade hydrofoil impellers

For low power consumption and high flow rate. Delivered as loose blades for easy assembly.



### Leveling flange with gas seal

This accessory aligns motor housing with shaft to eliminate the risk of increased shaft load and gas leakage. Horizontal position can easily be adjusted by a single person.



### Rotating shaft stabilizer

This accessory prevents shaft runout by securely affixing the shaft end to the digester bottom with a tight swivel coupling assembly.

# Peak performance starts on top

## Facts and figures

Model	SY4850	SY4860	SY4870
Main application	Denitrification	Municipal digesters	Municipal digesters
Installed electric power			
· 50 Hz, kW	2.2-7.5	1.5-4.0	5.5-15
· 60 Hz, kW	2.6-9.0	1.8-4.8	6.6-18
Impeller speed			
· 50 Hz, rpm	18-44	10-24	12-23
· 60 Hz, rpm	22-59	12-29	14-28
Impeller diameters			
· Flygt banana, m (in)	2.5 (98)	-	-
· 3-blade steel, m (in)	1.5 (59) - 2.5 (98)	1.5 (59) - 3.0 (118)	2.0 (79) - 4.0 (157)
Max thrust, N	6,000	6,000	13,500
Working volumes	ox/anox basin	Up to 2,000 m <sup>3</sup>	Up to 5,000 m <sup>3</sup>
Approved for use in hazardous environments	-	Yes	Yes
Accessories	Bottom support	Shaft stabilizer Leveling flange	Shaft stabilizer Leveling flange
Max. temperature	50°/80°C	80°C	80°C

## Thrust ranges

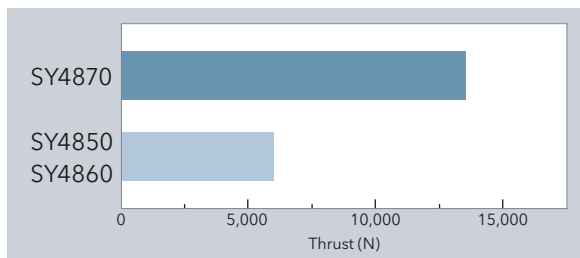

## Empower system performance



With Flygt monitoring and control products from Xylem, you can control and optimize mixer performance. This helps reduce stress on equipment, prolong service lifetime and enable early detection of any maintenance requirements.

### Variable frequency drive

To regulate the speed of Flygt top-entry agitators, there's Flygt PS 200, a variable frequency drive unit for

smooth startups and stops. The VFD senses demand for increased power and reverses the drive for impeller cleaning. Built-in communication interfaces for PLC and SCADA systems.

# A perfect blend of support and service



## Boost efficiency with monitoring and control

We supply everything from controllers, sensors and start equipment to SCADA software for complete fluid handling supervision.



**A deep understanding of fluid handling and vast experience in mixing technologies make Xylem a reliable partner for your wastewater process requirements.**

### Systems engineering expertise

Dimensioning and layout are critical factors in maximizing performance. Using our expertise and intelligent tools, we analyze your requirements to identify the right mixer or agitation system to optimize your processes.

### Support along the way

Our recommendations result from the use of specially developed and validated Computational Fluid Dynamics software programs, based on carefully selected, relevant models. Our own testing facilities as well as field testing and measurement of actual performance onsite provide Xylem engineers with keen insight into what works. Using this knowledge and expertise, we help you maintain your mixing installation in top operating condition.

### Global service network

Should any problem occur with your Flygt agitators and mixers, professional assistance and original spare parts are always within easy reach through Xylem's extensive service network in 140 countries.



## Enjoy the benefits of a premium brand

Genuine spare parts are vital to ensure long and trouble-free operation. We guarantee the availability of spare parts for 10 years after we stop production of a model.

# Xylem ['zīləm]

- 1) The tissue in plants that brings water upward from the roots
- 2) A leading global water technology company

We're 12,000 people unified in a common purpose: creating innovative solutions to meet our world's water needs. Developing new technologies that will improve the way water is used, conserved, and re-used in the future is central to our work. We move, treat, analyze, and return water to the environment, and we help people use water efficiently, in their homes, buildings, factories and farms. In more than 150 countries, we have strong, long-standing relationships with customers who know us for our powerful combination of leading product brands and applications expertise, backed by a legacy of innovation.

For more information on how Xylem can help you, go to [xylem.com](http://xylem.com).



Flygt is a brand of Xylem. For the latest version of this document and more information about Flygt products visit [www.flygt.com](http://www.flygt.com)