

# Liquid ring compressors

## KPH 65112, KPH 65118, KPH 65127

**Compression pressure:** 1 to 3,5 bar  
**Suction volume flow:** 330 to 840 m<sup>3</sup>/h

### CONSTRUCTION TYPE

Sterling SIHI liquid ring compressors are displacement compressors of simple and robust construction having following special characteristics:

- Pumping of nearly all gases and vapours
- non polluting due to a nearly isothermal compression
- oil-free, as no lubrication in the working chamber
- additional liquid can be handled with the gas flow
- easy maintenance and reliable operation
- low noise and nearly free from vibration
- wide choice of material, therefore applicable nearly anywhere
- no metallic contact of the rotating parts

The Sterling SIHI liquid ring compressors KPH 65112, KPH 65118 and KPH 65127 are two stage compressors.



### APPLICATION

Every application where pumping gas has to be compressed carefully to a pressure of abt. 3,5 bar and only a small increase in temperature is admissible;  
 e.g. recovery of solvent or vinyl chloride vapour.

### NOTE

During the operation the compressor must continuously be supplied with service liquid, normally water, in order to eliminate the heat resulting from the gas compression and to replenish the liquid ring, because part of the liquid is leaving the compressor together with the gas. This liquid can be separated from the gas in a pressure liquid separator (see catalogue part accessories).  
 It is possible to reuse the service liquid.  
 The direction of rotation is clockwise when looking from the drive on the pump.

### GENERAL TECHNICAL DATA

		unit	KPH 65112	KPH 65118	KPH 65127
Speed	50 Hz	rpm	1475		
	60 Hz		1775		
Max. compression over pressure		bar	3,5		
Hydraulic test (over pressure)		bar	6		
Moment of inertial of the rotating pump parts and of the water filling		kg · m <sup>2</sup>	0,48	0,7	0,98
Sound pressure level of measuring area		dB (A)	82 ... 84		
Min. pulley diameter permissible in case of V-belt drive	50 Hz	mm	315		315
	60 Hz		315		355
Max. gas temperature		°C	100		
Service liquid					
max. admissible temperature		°C	80		
max. viscosity		mm <sup>2</sup> /s	90		
max. density		kg/m <sup>3</sup>	1200		
volume up to shaft level		liter	18	22	27

The combination of several limiting values is not admissible.

## Material Design

Item	COMPONENTS	MATERIAL DESIGN	
		02	42
1, 2	Casing	0.6025	1.4408
10, 11, 12, 13	Guide disk / intermediate piece	0.6025	1.4408
30, 31	Vane wheel impeller	1.4027.05	1.4517
35, 36	Central body	0.6025	1.4408
200	Shaft	1.0503	
270	Shaft sleeve	1.4021	1.4581
400	Gland packing	GORE	

## Sectional drawing KPH 65112, KPH 65118, KPH 65127

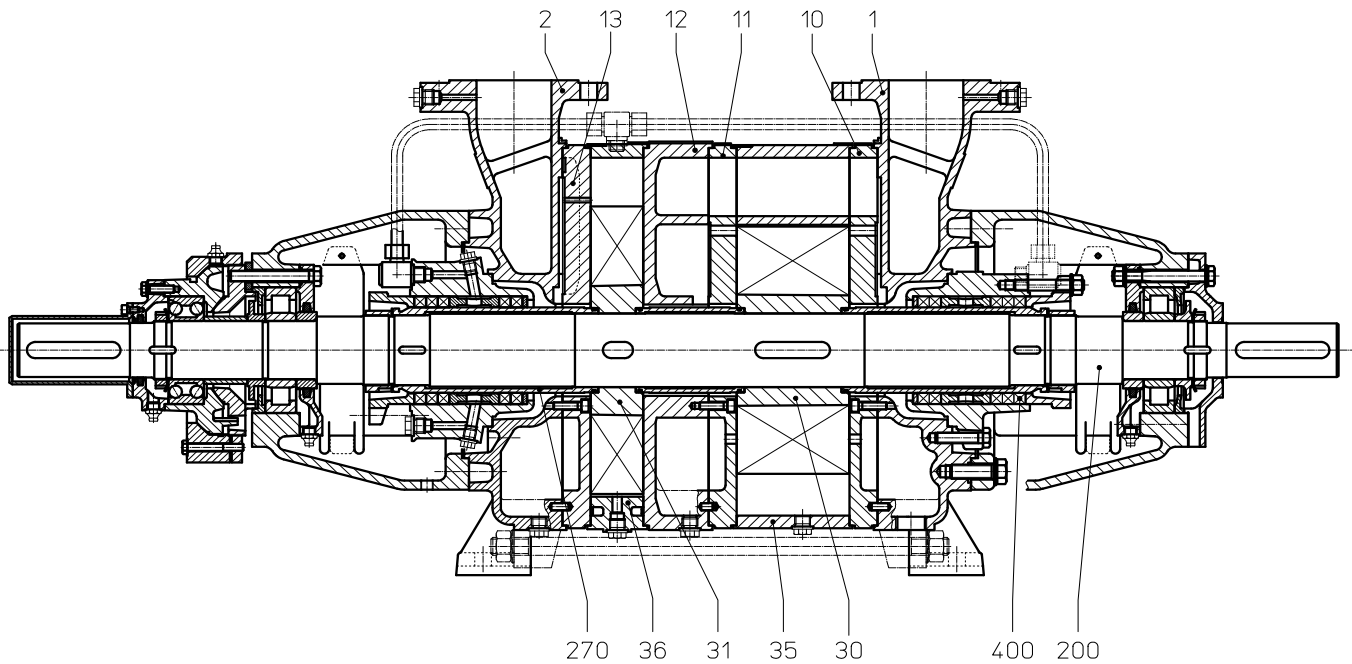

## Suction volume pressure and power absorption KPH 65112

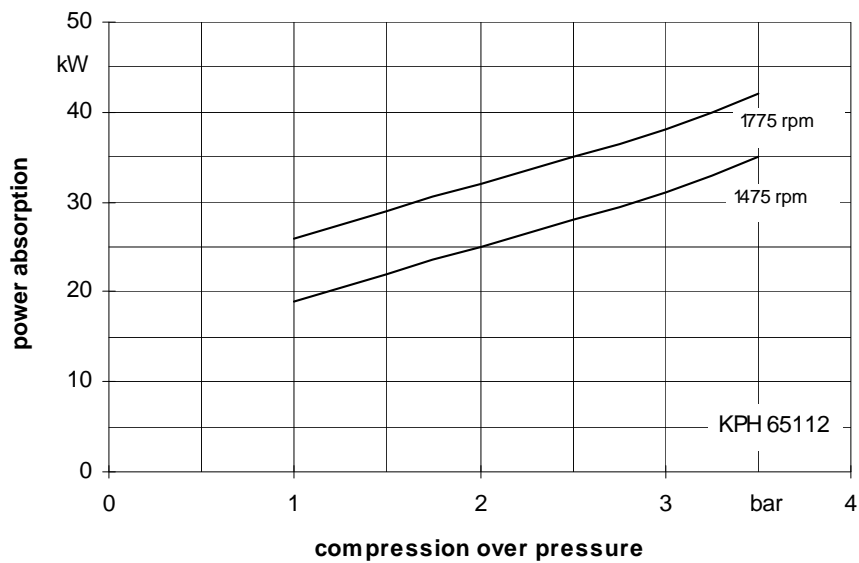
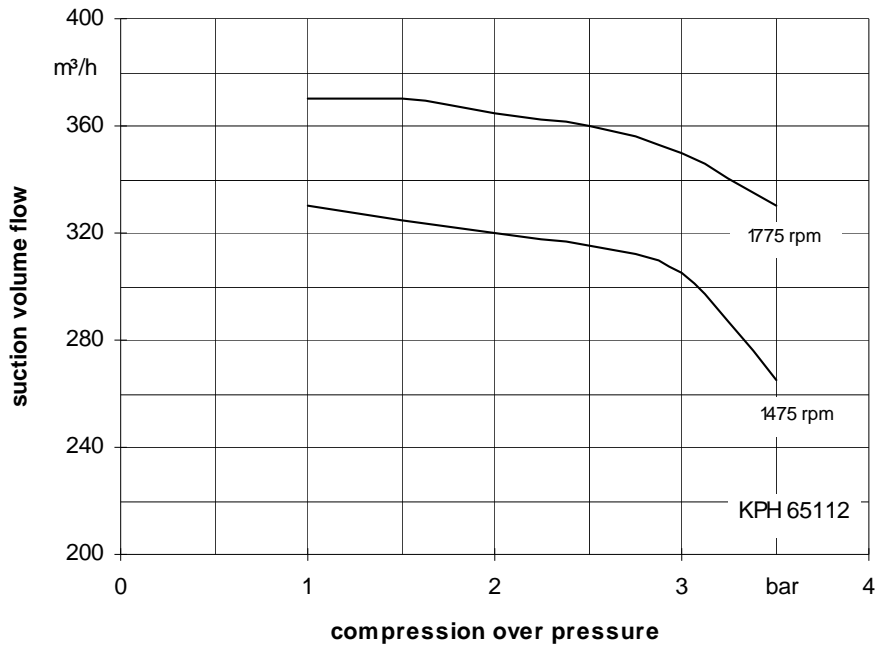

The values indicated for volume and power absorption are valid for compression of dry air at 20°C from atmospheric pressure (1013 mbar) of the respective compression pressure with water at 20°C as service liquid. Tolerance of the curve values is 10%. The compression pressure in bar is indicated as pressure above the atmospheric pressure.

The data indicated change with deviating service conditions, such as deviating physical data of the gas to be handled or of the service liquid (vapour pressure, temperature, density, viscosity) when handling entrained liquid, at a suction pressure deviating from atmospheric pressure handling gas-vapours mixtures.

For determination of service data for deviating service conditions please see catalogue section TH.

**Suction volume pressure and power absorption KPH 65118**

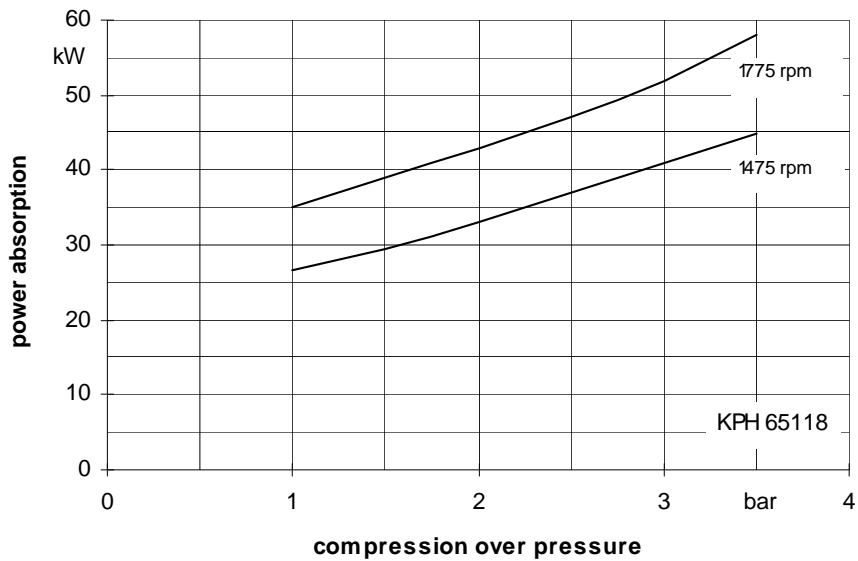
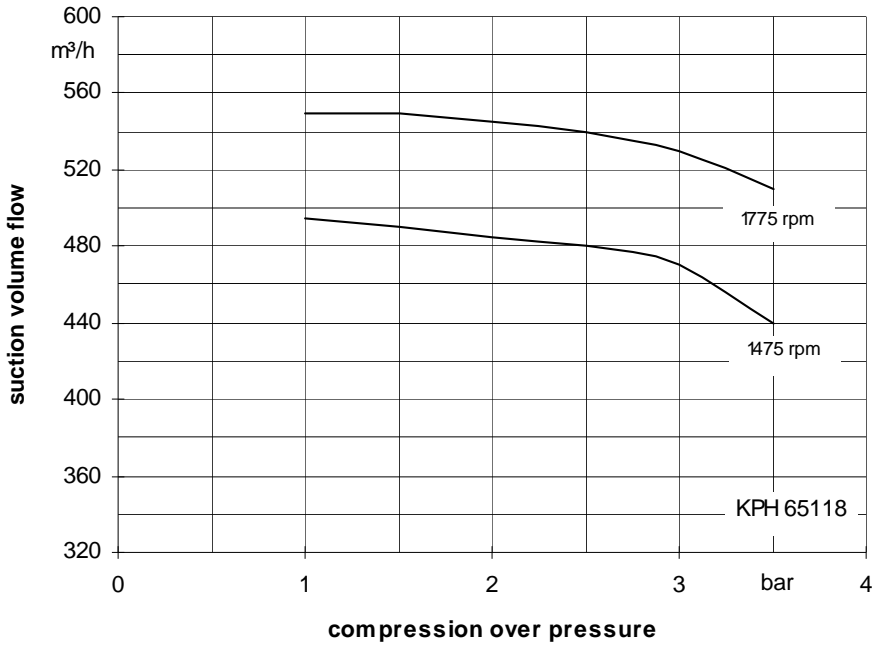

The values indicated for volume and power absorption are valid for compression of dry air at 20°C from atmospheric pressure (1013 mbar) of the respective compression pressure with water at 20°C as service liquid. Tolerance of the curve values is 10%. The compression pressure in bar is indicated as pressure above the atmospheric pressure.

The data indicated change with deviating service conditions, such as deviating physical data of the gas to be handled or of the service liquid (vapour pressure, temperature, density, viscosity) when handling entrained liquid, at a suction pressure deviating from atmospheric pressure handling gas-vapours mixtures.

For determination of service data for deviating service conditions please see catalogue section TH.

## Suction volume flow and power absorption KPH 65127

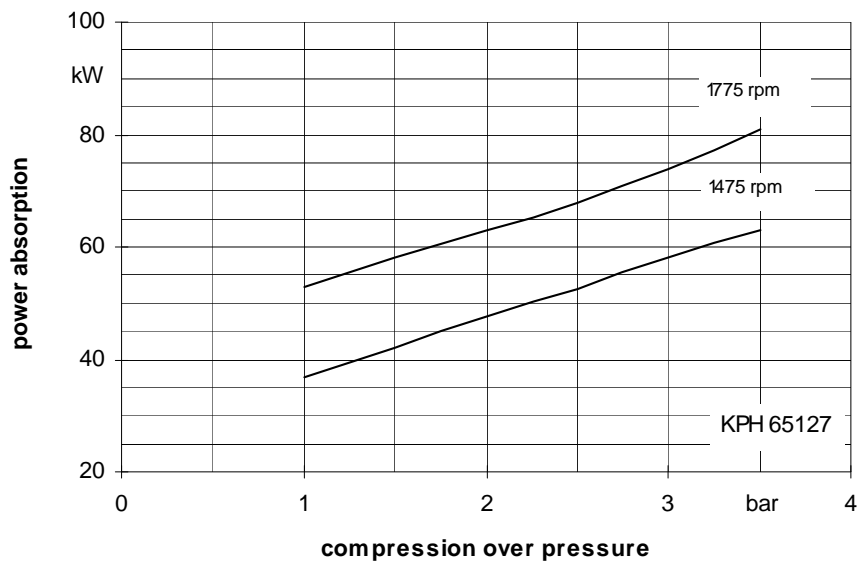
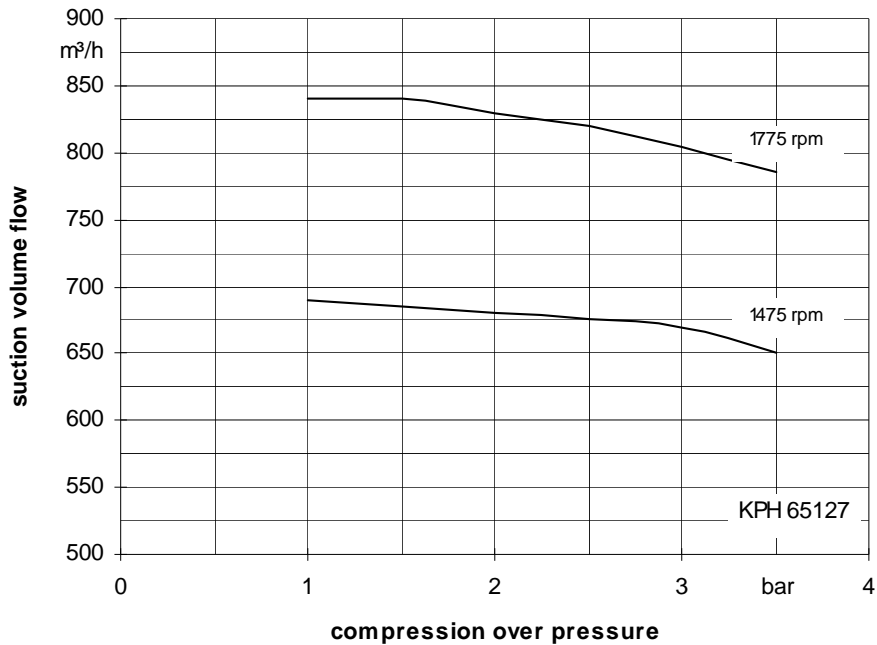

The values indicated for volume and power absorption are valid for compression of dry air at 20°C from atmospheric pressure (1013 mbar) of the respective compression pressure with water at 20°C as service liquid. Tolerance of the curve values is 10%. The compression pressure in bar is indicated as pressure above the atmospheric pressure.

The data indicated change with deviating service conditions, such as deviating physical data of the gas to be handled or of the service liquid (vapour pressure, temperature, density, viscosity) when handling entrained liquid, at a suction pressure deviating from atmospheric pressure handling gas-vapours mixtures.

For determination of service data for deviating service conditions please see catalogue section TH.

**Dimension table KPH 65112, KPH 65118, KPH 65127**

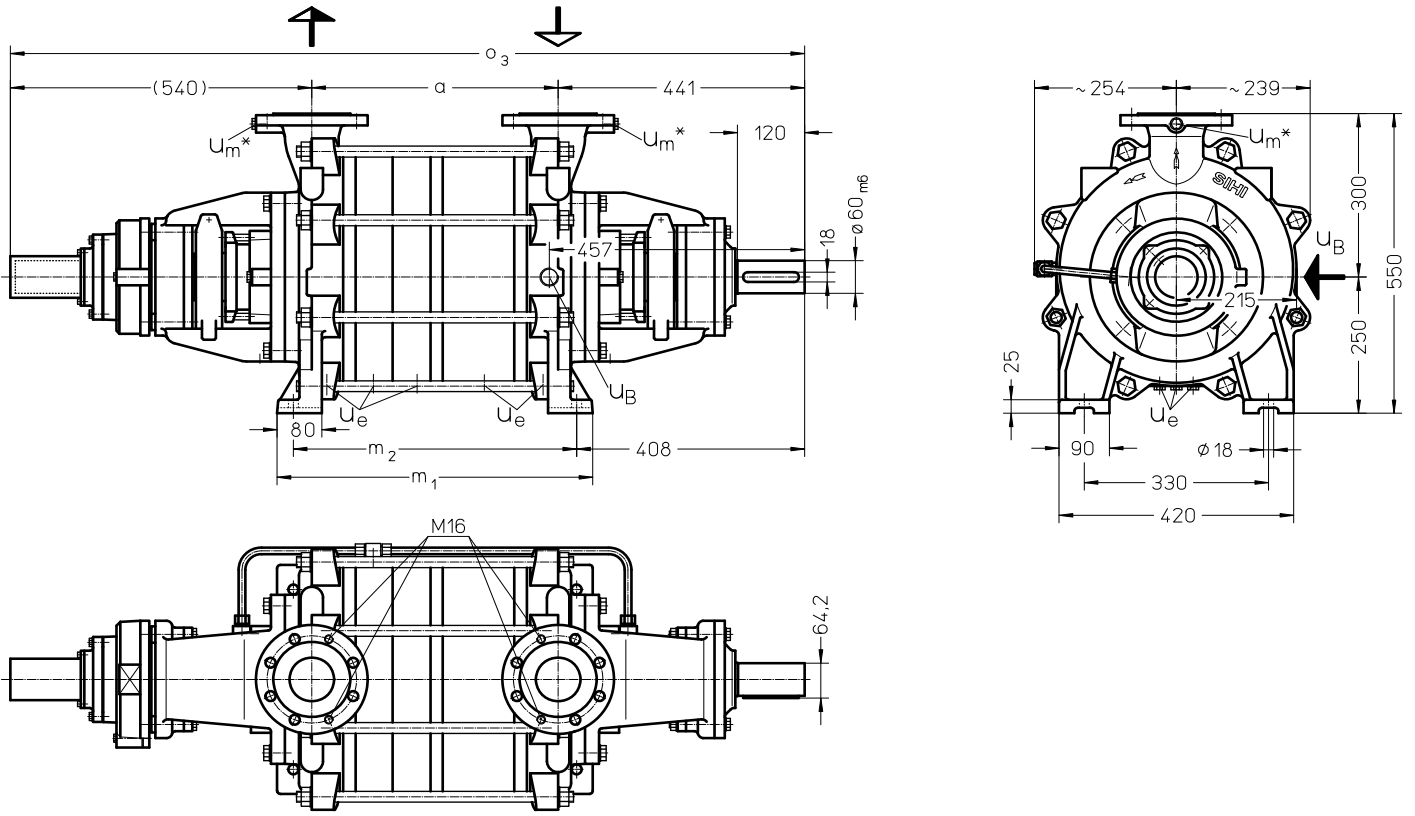

\* = not existing at material design 42

- N 1 = gas-inlet DN 80
- N 2 = gas-outlet DN 80
- $U_B$  = connection for service liquid G 1
- $U_e$  = drain connection G  $\frac{3}{8}$
- $U_m$  = connection for pressure gauge G  $\frac{3}{8}$

	a	$m_1$	$m_2$	$o_3$	weight abt. kg
KPH 65112	441	565	507	1422	400
KPH 65118	528	652	594	1509	445
KPH 65127	645	769	711	1626	500

flange connections to DIN 2501 PN 10	
DN	80
k	160
D	200
number x $d_2$	8x18

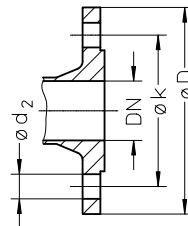

**Arrangement drawing KPH 65112, KPH 65118 with pressure liquid separator**

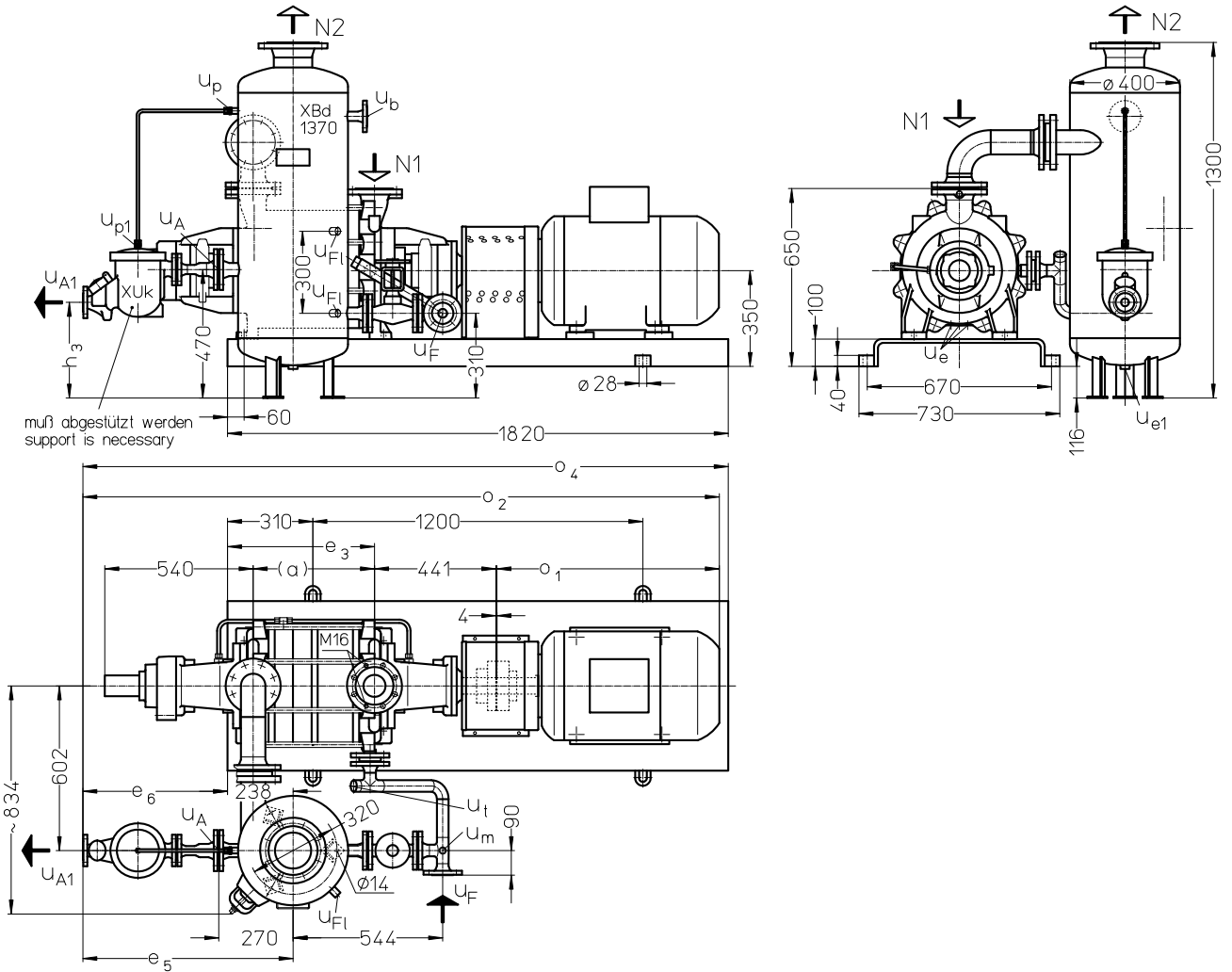

- N 1 = gas-inlet DN 80
- N 2 = gas-outlet DN 125
- U<sub>F</sub> = connection for fresh liquid DN 32
- U<sub>A</sub> = connection for liquid drain DN 40
- U<sub>A1</sub> = connection for liquid drain (XUk 2604)
- U<sub>A1</sub> = connection for liquid drain (XUk 3304)
- U<sub>b</sub> = connection for safety valve DN 25
- U<sub>e</sub> = drain connection G 3/8
- U<sub>e1</sub> = drain connection G 3/4
- U<sub>Fl</sub> = connection for liquid level indicator G 1/2
- U<sub>m</sub> = connection for pressure gauge G 1/2
- U<sub>p</sub> = connection for hanging gas line G 3/8
- U<sub>p1</sub> = connection for hanging gas line G 1/4
- U<sub>t</sub> = connection for thermometer G 1/2

flange connections to DIN 2501 PN 10/16					
DN	25	32	40	80	125
k	85	100	110	160	210
D	115	140	150	200	250
number x d <sub>2</sub>	4x14	4x18	4x18	8x18	8x18

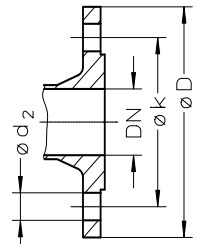

	E-Motor 50Hz			a	e <sub>3</sub>	e <sub>5</sub>	e <sub>6</sub>	h <sub>3</sub>	o <sub>1</sub> *	o <sub>2</sub> *	o <sub>4</sub>	weight		
	size	EEEx e II T3	kw									compressor + coupling + motor + base frame	as above + XBd + bend + Xuk + reduction	
			kw									abt. kg	abt. kg	
KPH	65112	225S	37	-	441	534	764	526	350	809	2314	2346	800	950
		225M	-	36						875	2380		925	1075
	65118	225M	45	-	528	621	779	541	335	809	2416	2361	815	970
		250M	-	44						971	2578		1025	1175

\* Dimensions and position of the connection box depend on the motor make.

# Arrangement drawing KPH 65127 with pressure liquid separator

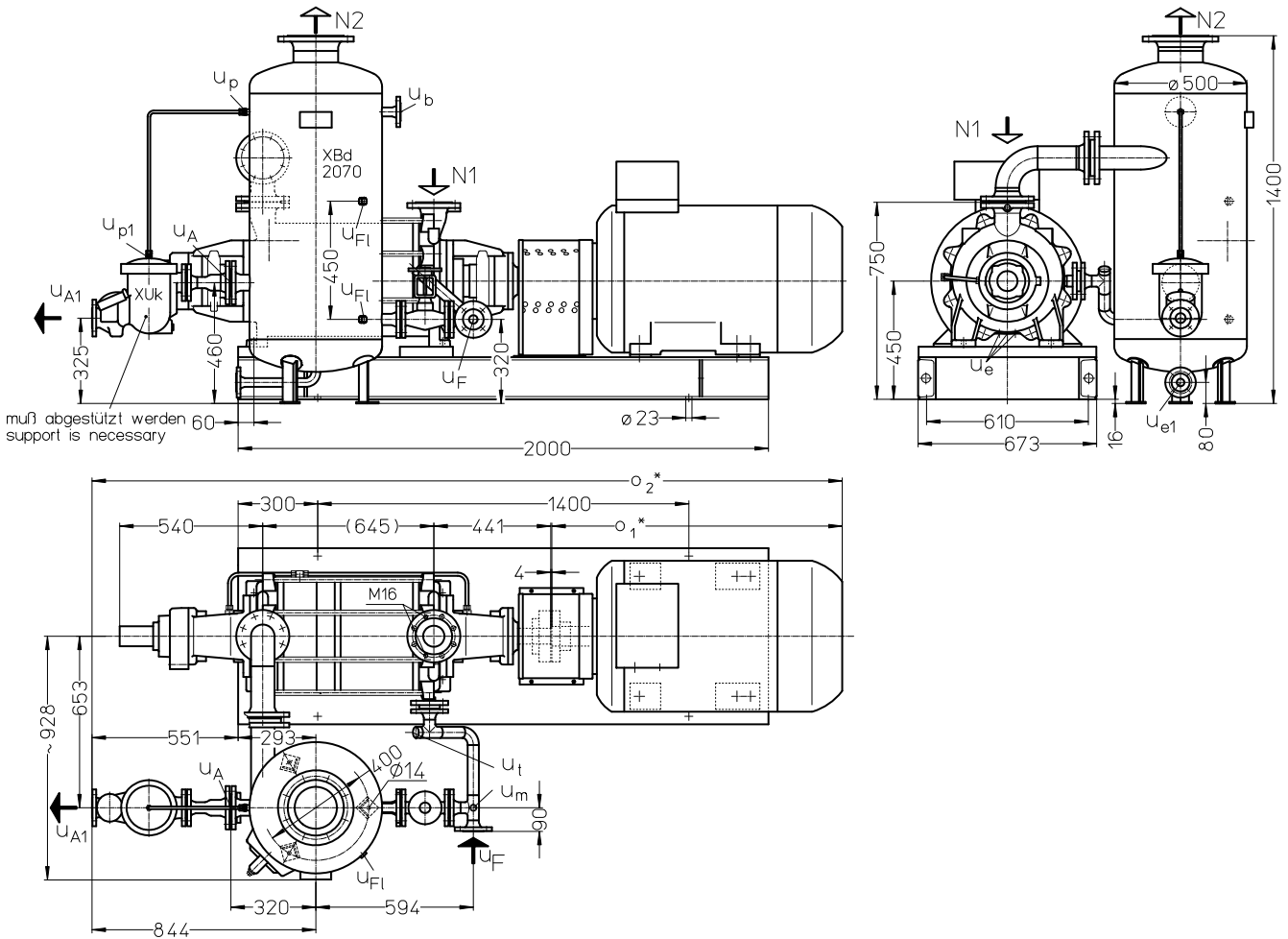

- N 1 = gas-inlet DN 80
- N 2 = gas-outlet DN 150
- U A = connection for liquid drain DN 50
- U A1 = connection for liquid drain DN 32
- U b = connection for safety valve DN 25
- U e = drain connection G 3/8
- U e1 = drain connection DN 25
- U F = connection for fresh liquid DN 32
- U FI = connection for liquid level indicator G 1/2
- U m = connection for pressure gauge G 1/2
- U p = connection for hanging gas line G 3/8
- U p1 = connection for hanging gas line G 1/4
- U t = connection for thermometer G 1/2

	electric motor 50Hz		EEEx e II T3	O <sub>1</sub> *	O <sub>2</sub> *	weight	
	size	kW				compressor + coupling + motor + base frame	as above + XBd + bend + Xuk + reduction
						abt. kg	abt. kg
KPH 65127	280S	75	-	1005	2740	1150	1350
	280M	-	70	1095	2830	1170	1370

flange connections to DIN 2501 PN 10/16					
DN	25	32	50	80	150
k	85	100	145	160	240
D	115	140	185	200	285
number x d <sub>2</sub>	4x14	4x18	4x18	8x18	8x22

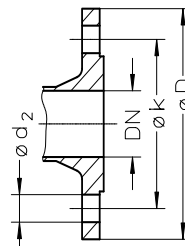

\* Dimensions and position of the connection box depend on the motor make.



**Fresh water requirements** in [m<sup>3</sup>/h] dependent on compression pressure, speed, mode of operation and temperature difference

compressor	speed [rpm]	*	FB not depending on the pressure [m <sup>3</sup> /h]	KB= combined liquid service with service liquid 30°C, 20°C, 10°C, 5°C warmer than the make-up water																			
				compression pressure																			
				1 bar				2 bar				3 bar				3,5(50Hz) / 4(60Hz) bar							
				difference in temperature [°C]				difference in temperature [°C]				difference in temperature [°C]				difference in temperature [°C]							
30		20		10		5		30		20		10		5		30		20		10		5	
KPH 65112	1475	0,25	1,8	0,42	0,56	0,86	1,16	0,51	0,67	0,98	1,27	0,59	0,77	1,07	1,35	0,64	0,81	1,12	1,38				
	1775	0,4	2,2	0,56	0,74	1,11	1,47	0,65	0,85	1,22	1,57	0,73	0,94	1,31	1,65	0,78	0,99	1,37	1,69				
KPH 65118	1475	0,4	2,4	0,58	0,77	1,17	1,57	0,68	0,89	1,30	1,69	0,79	1,02	1,43	1,79	0,84	1,07	1,48	1,83				
	1775	0,6	2,9	0,74	0,99	1,48	1,96	0,86	1,13	1,62	2,08	0,98	1,26	1,76	2,19	1,06	1,34	1,83	2,25				
KPH 65127	1475	0,6	3,0	0,78	1,04	1,54	2,04	0,94	1,22	1,74	2,20	1,07	1,36	1,87	2,31	1,13	1,42	1,93	2,35				
	1775	0,9	3,6	1,07	1,39	2,01	2,58	1,20	1,54	2,16	2,70	1,33	1,69	2,30	2,81	1,41	1,77	2,37	2,86				

FB = make-up liquid service

\* = In order to secure the service liquid flow the service liquid pressure shall be higher than the suction pressure by the following values

### Data regarding the pump size - order hints

In the following listed are our standard compressors, special design on request

	bearings	shaft sealing	material design	case sealing
	B· two antifriction bearings ·P two shaft ends clockwise rotating	041 double gland packing	02 main parts cast iron, without non-ferrous metal 42 main parts Cr Ni Mo - steel	0 liquid seal
KPH 65112 KPH 65118 KPH 65127	BP	041	02, 42	0

## Accessories

recommended accessories		KPH 65112	KPH 65118	KPH 65127
<b>Pressure liquid separator</b>	type/ weight	XBd 1370 / 105 kg		XBd 2070 / 150 kg
Material design	130 / steel	35 000 323		35 018.053
	galvanized	35 000 324		35 000 328
	172 / 1.4571			
Bend				
material design	072 / 1.0254		35 003 229	
	172 / 1.4571		35 003 230	
Service liquid line				
material design	072 / 1.0254	35 003 157	35 003 159	35 003 160
	172 / 1.4571	35 003 158	on request	on request
Regulating valve to DIN 3356/ DIN 3201-F1				
material design	GG-25		on request	
	1.4408		on request	
<b>Liquid discharge trap</b>	type / weight	XUk 2604 / 15 kg	XUk 3304 / 22 kg	
material design	762 / GG20+1.4541	43 014 802	43 043 796	
Reduction				
Material design	072 / 1.0254	on request	35 009 225	on request
Hanging gas line				
Material design	072 / 1.0254	35 009 242		on request
<b>Motor</b> dependent on operating point e.g.:				
IP 55	size	225 S	225 M	280 S
	power	37 kW	45 kW	75 kW
	weight	215 kg	235 kg	610 kg
EEx e II T3	size	225 M	250 M	280 M
	power	36 kW	44 kW	70 kW
	weight	340 kg	440 kg	630 kg
<b>Coupling</b> dependent on motor size				
for Motor IP 55	type / weight	A 180 / 14 kg	A 180 / 14 kg	A 180 / 14 kg
pump side	SIHI part No.	43 035 527	43 035 527	43 035 527
motor side	SIHI part No.	43 021 496	43 021 496	43 021 495
for motor EEx e II T3	type / weight	ADS 194 / 17 kg	ADS 194 / 17 kg	ADS 194 / 17 kg
pump side	SIHI part No.	43 040 600	43 040 600	43 040 600
Motor side	SIHI part No.	43 028 518	43 035 601	43 038 678
<b>Contact safety device</b> dependent on motor size				
material design	076 / 1.0330	43 042 346		43 042 350
	345 / 2.0321	43 042 347		43 042 351
<b>Base plate / base frame</b>				
material design	081 / 1.0038	S 609 / 158 kg		- / 155 kg
		43 040 975		35 002 951
<b>Base support</b>				
for motor size 225	003 / 0.6025	4x 43 041 078		
for motor size 280	003 / 0.6025			4x 43 042 998

Any changes in the technical development are reserved.

### Sterling SIHI GmbH

Lindenstraße 170, D-25524 Itzehoe, Germany, Telephone +49 (0) 48 21 / 7 71 - 01, Fax + 49 (0) 48 21 / 7 71 - 274