

Submersible Mixer

Amamix

Type Series Booklet

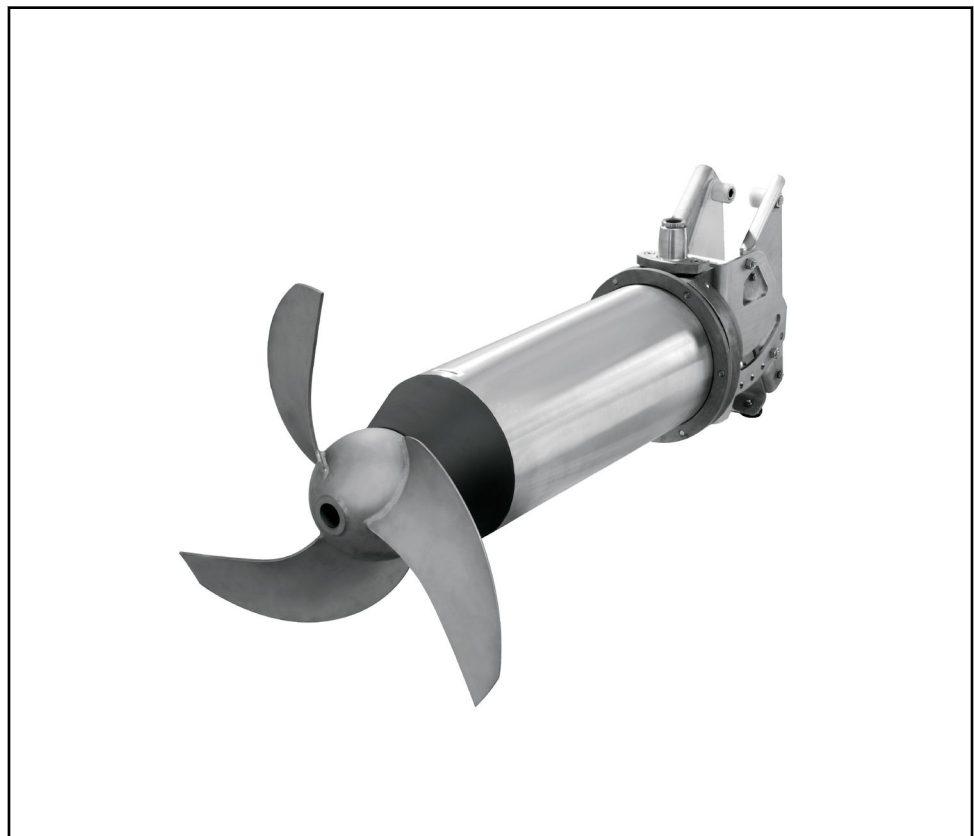

Legal information/Copyright

Type Series Booklet Amamix

All rights reserved. The contents provided herein must neither be distributed, copied, reproduced, edited or processed for any other purpose, nor otherwise transmitted, published or made available to a third party without the manufacturer's express written consent.

Subject to technical modification without prior notice.

© KSB Aktiengesellschaft, Frankenthal 03.11.2015

Contents

Waste Water	5
Submersible Mixer	5
Amamix	5
Main applications	5
Fluids handled	5
Operating data	5
Designation	5
Design details	5
Materials	6
Product benefits	6
Acceptance tests / Warranties	6
Standard and special designs	7
Selection information	7
Minimum level of fluid handled	7
Programme overview / selection tables	8
Overview of range	8
Submersible mixer / motor combinations	9
Dimensions	10
Amamix 200, 400 V, 50 Hz, n = 1400 rpm, material variant G - version without jet ring	10
Amamix 200, 400 V, 50 Hz, n = 1400 rpm, material variant C - version without jet ring	11
Amamix 300, 400 V, 50 Hz, n = 920 rpm, material variant G - version without jet ring	12
Amamix 300, 400 V, 50 Hz, n = 920 rpm, material variant C - version without jet ring	14
Amamix 400, 400 V, 50 Hz, n = 700 rpm, material variant G - version without jet ring	16
Amamix 400, 400 V, 50 Hz, n = 700 rpm, material variant C - version without jet ring	18
Amamix 600, 400 V, 50 Hz, n = 475 rpm, material variant G - version without jet ring	20
Amamix 600, 400 V, 50 Hz, n = 475 rpm, material variant C - version without jet ring	22
Amamix 300, 400 V, 50 Hz, n = 920 rpm, material variant G - version with jet ring	24
Amamix 300, 400 V, 50 Hz, n = 920 rpm, material variant C - version with jet ring	25
Amamix 400, 400 V, 50 Hz, n = 700 rpm, material variant G - version with jet ring	26
Amamix 400, 400 V, 50 Hz, n = 700 rpm, material variant C - version with jet ring	27
Amamix 600, 400 V, 50 Hz, n = 475 rpm, material variant G - version with jet ring	28
Amamix 600, 400 V, 50 Hz, n = 475 rpm, material variant C - version with jet ring	29
Scope of supply	30
Accessories	31
Overview of accessories	31
Accessories set 4	33
Accessories set 6	35
Accessories set 7	37
Accessories set 22	40
Forcing screws	63
Guide rails	64
Wear-resistant adapter	64
Cable support/carabine hook	65
Scope of supply	67
General assembly drawings with list of components	69

Amamix 200 - motor housing material stainless steel	69
Amamix 200 - motor housing material grey cast iron	70
Amamix 300/400/600 - motor housing material stainless steel	71
Amamix 300/400/600 - motor housing material grey cast iron	72
Enquiry sheet	73

Waste Water

Submersible Mixer

Amamix



Main applications

- Mixing
- Homogenisation
- Sludge thickening
- Sludge holding tanks
- Primary sedimentation tanks
- Secondary sedimentation tanks
- Heat transfer optimisation
- Maintaining clean pump sumps
- Preventing the formation of deposits at tank walls and floors
- Breaking up and transporting floating sludge

Fluids handled

- Industrial waste water
- Waste water with faeces
- Faecal-free waste water
- Activated sludge
- Digested sludge
- Raw sludge

Operating data

Operating properties

Characteristic		Value
Propeller diameter	D [mm]	225 - 630
Power range	P [kW]	≤ 10
Fluid temperature	T [°C]	≤ 40
Installation depth	ET [m]	≤ 30

Designation

Example: Amamix C 57 3 5 R / 10 12 YD G

Designation key

Code	Description	
Amamix	Type series	
C	Propeller material	
	C	Stainless steel
G	Grey cast iron	
57	Nominal propeller diameter, e.g. 570 mm	
3	Number of blades	
	2, 3	
5	Code for incidence angle of propeller	
	1, 5, 6, 8	
R	1)	Version without jet ring
	R	Version with jet ring
10	Motor size	
	0, 2, 3, 4, 6, 8, 10	
12	Number of motor poles	
	4, 6, 8, 12	
YD	Motor variant	
	UD/UM	Standard design
	YD/YM	Explosion protection to ATEX
C	Casing material	
	C	Stainless steel
G	Grey cast iron	

Design details

Design

- Fully flooded submersible mixer
- Horizontal installation (with pitch adjustment)

Propeller

- Self-cleaning (ECB) propeller

Shaft seal

- Two bi-directional mechanical seals in tandem arrangement, with liquid reservoir

Bearings

- Grease-packed rolling element bearings sealed for life

Drive

- Three-phase asynchronous squirrel-cage motor
- Motors integrated in explosion-proof submersible mixers are supplied in Ex d IIB type of protection.

1) Blank

Materials

Overview of available materials

Component		Material variant	
		G	C
Motor housing		EN-GJL-250	1.4581
Motor housing cover		EN-GJL-250	1.4517
Casing cover		EN-GJL-250	1.4571
Propeller		PU ²⁾³⁾	1.4571
Mechanical seal	Propeller end	SiC/SiC	
	Drive end	SiC/SiC	
Shaft		1.4571 ⁴⁾	
Elastomer seals		Viton (FPM)	
Screws/bolts		A4 (corresponds to 1.4571)	
Guide bracket		EN-GJL-250	1.4571
Supporting clamp		1.4571	
Jet ring (optional)		1.4571	

prior consent will result in the forfeiture of any and all claims for damages. The same applies to consequential damage (e.g. resultant process downtime).

Product benefits

- High operating reliability due to dry, pressure-tight and encapsulated squirrel-cage motor, thermal class F
- Increased reliability due to bi-directional mechanical seal
- Temperature sensors prevent overheating of the motor
- Marked reduction of energy costs due to optimised propeller design
- Environmentally friendly oil fill
- Ease of service with bolts made of stainless steel which are easy to undo even after years of operation
- Absolutely watertight cable entry

Acceptance tests / Warranties

- Functional test
Every submersible mixer is subjected to a functional test to KSB standard ZN 56525.
- Quality is assured by means of an audited and certified quality assurance system to DIN EN ISO 9001.
- Special acceptance tests are available on request.

Warranty information

Our warranty is based on and exclusively applies to your specifications as documented in the data sheet of the submersible mixer, and covers the relevant physical properties. Any warranty claims beyond the aforementioned aspects, as well as any claims resulting from an excessive solids content in the plant, the formation of floating blankets as well as failure to produce a specific gas yield, shall be excluded. The correct positioning of the submersible mixers is crucial for the overall function of the equipment. KSB's warranty obligations shall not cover any damage that may occur as a result of incorrect mixer positioning, i. e. installing the mixer in a position not expressly approved by KSB. In addition, low-flow areas (flow separation) resulting from the tank geometry shall not be covered by our warranty. Furthermore, we shall not assume any liability if our submersible mixers are used in patented processes and/or in case of protected rights of third parties.

Unauthorised modifications, the mixer's use for fluids and operating conditions not specified in the purchase order, as well as the use of non-KSB installation parts without KSB's

²⁾ Polyurethane

³⁾ Optional: 1.4571

⁴⁾ Amamix 600 G in 1.4021

Standard and special designs

Standard and special designs

Option	Comments
Analysing device for leakage sensor	Available for all sizes
Propeller in 1.4571 instead of polyurethane	Amamix 200 in material variant G, for fluids containing coarse solids
Propeller C2227 instead of V2227	
Propeller C2223 instead of V2230	
Propeller C2233 instead of V2235	
Bail	All sizes
Wear-resistant adapter	Amamix 300/400/600, (⇒ Page 64)
Additional operating manuals	Standard: 1 operating manual per pump set
Flow simulation	Available for all sizes

For any versions not documented in this type series booklet or special versions please always contact KSB for technical details, prices and delivery periods.

Examples:

- Other voltages
- Special coatings
- Combinations with special motor/special propeller (e.g. for higher-viscosity fluids)
- Special installation parts
- Versions for higher application temperatures
- Other mechanical seal and elastomer materials

A minimum distance h_1 should also be kept from any vertical walls. If more than one submersible mixer is installed, the mixers should be spaced at a distance $\varnothing D$. Reflections of the water jet and flow turbulence must be taken into account.

With accessories set 6 for shallow tanks and racetracks, the floor clearance h_1 can be reduced to approx. 50 mm. Condition: solid floor (concrete/steel/plastics)

Selection information

Minimum level of fluid handled

The submersible mixer is operational when the fluid level is not lower than dimension W_T . This minimum level of the fluid handled must also be ensured during automatic operation.

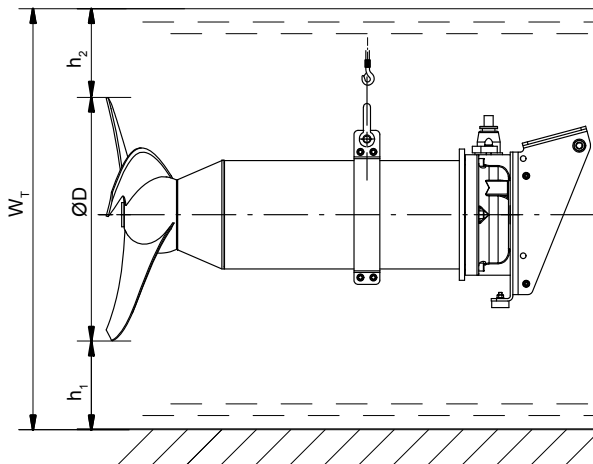

Minimum level of fluid handled

Minimum level of fluid handled

$\varnothing D$ [mm]	$h_{1 \min}$ [m]	$h_{2 \min}$ [m]	$W_{T \min}$ [m]
200	0,12	0,50	0,82
300	0,15	0,80	1,25
400	0,20	0,85	1,45
600	0,30	1,00	1,90

Programme overview / selection tables
Overview of range

Overview of range (material variants G, C)

Feature	Amamix 200		Amamix 300		Amamix 400		Amamix 600	
	G	C	G	C	G	C	G	C
Number of motor poles								
4	1 4 UD/YD 2 4 UD/YD	-	-	-	-	-	-	-
6	-	0 6 UD/YD 2 6 UD/YD	-	-	-	-	-	-
8	-	-	3 8 UD/YD 4 8 UD/YD	-	-	-	-	-
12	-	-	-	-	6 12 UDG/YDG 10 12 UDG/YDG	4 12 UMC/YMC 8 12 UMC/YMC	-	-
Power range	Up to 2.5 kW		Up to 3.2 kW		Up to 4 kW		Up to 10 kW	
Explosion protection								
Version UD/UM	-							
Version YD/YM	⊕ II2G Ex dc IIB T4							
Motor								
Starting method	DOL				DOL or star-delta			
Voltage and frequency	400 V ⁵⁾ 50 Hz, suitable for operation on a frequency inverter							
Cooling	Cooled by surrounding fluid							
Immersion depth	Up to 30 m							
Power cable								
Length	10 m ⁶⁾							
Cable entry	Absolutely watertight							
Type	See table "Overview of power cables"							
Bearings	Grease-packed rolling element bearings sealed for life							
Sealing elements								
Elastomer seals	Viton (fluorocarbon rubber FPM)							
Shaft seal	Bellows-type mechanical seal ⁷⁾							
Monitoring								
Winding temperature	PTC							
Motor leakage	Leakage sensor in the motor space							
Mechanical seal leakage	Optional: leakage sensor in the oil reservoir (UD/UM version and material variant C only)							
Coating								
Material variant G	Two-component epoxy resin coating							
Material variant C	-							
Permissible fluid temperature	40 °C							
Acceptance tests	To ISO 9001 ⁸⁾							
Installation								
Stationary	Installation depth up to 30 m							

Overview of power cables

Feature	S1BN8-F rubber-sheathed cable	S07RC4N8-F rubber-sheathed cable	TEHSITE Tefzel cable
Design	Standard	Optional	Optional
Rated voltage	1000 V	750 V	750 V
EMC screening	-	✓	-
Insulation material	EPR ⁹⁾	EPR ⁹⁾	ETFE ¹⁰⁾
Max. continuous temperature of insulation	90 °C	90 °C	135 °C
For permanent immersion in waste water to DIN VDE 0282-16/HD22.16	✓	✓	✓

- 5) Optional: 500 V and 690 V on request
 6) Optional: 15 m, 20 m, > 20 m on request
 7) Optional: mechanical seal with covered spring
 8) Optional: with test report EN 10204-2.2
 9) EPR = ethylene propylene rubber
 10) ETFE = ethylene tetrafluoroethylene

Submersible mixer / motor combinations

Overview of submersible mixer / motor combinations

Size	Motors									
	1 4	2 4	0 6	2 6	3 8	4 8	4 12	6 12	8 12	10 12
Motor housing material grey cast iron										
200 G	X	X	-	-	-	-	-	-	-	-
300 G	-	-	X	X	-	-	-	-	-	-
400 G	-	-	-	-	X	X	-	-	-	-
600 G	-	-	-	-	-	-	-	X	-	X
Motor housing material stainless steel										
200 C	X	X	-	-	-	-	-	-	-	-
300 C	-	-	X	X	-	-	-	-	-	-
400 C	-	-	-	-	X	X	-	-	-	-
600 C	-	-	-	-	-	-	X	-	X	-

Dimensions

Amamix 200, 400 V, 50 Hz, n = 1400 rpm, material variant G - version without jet ring

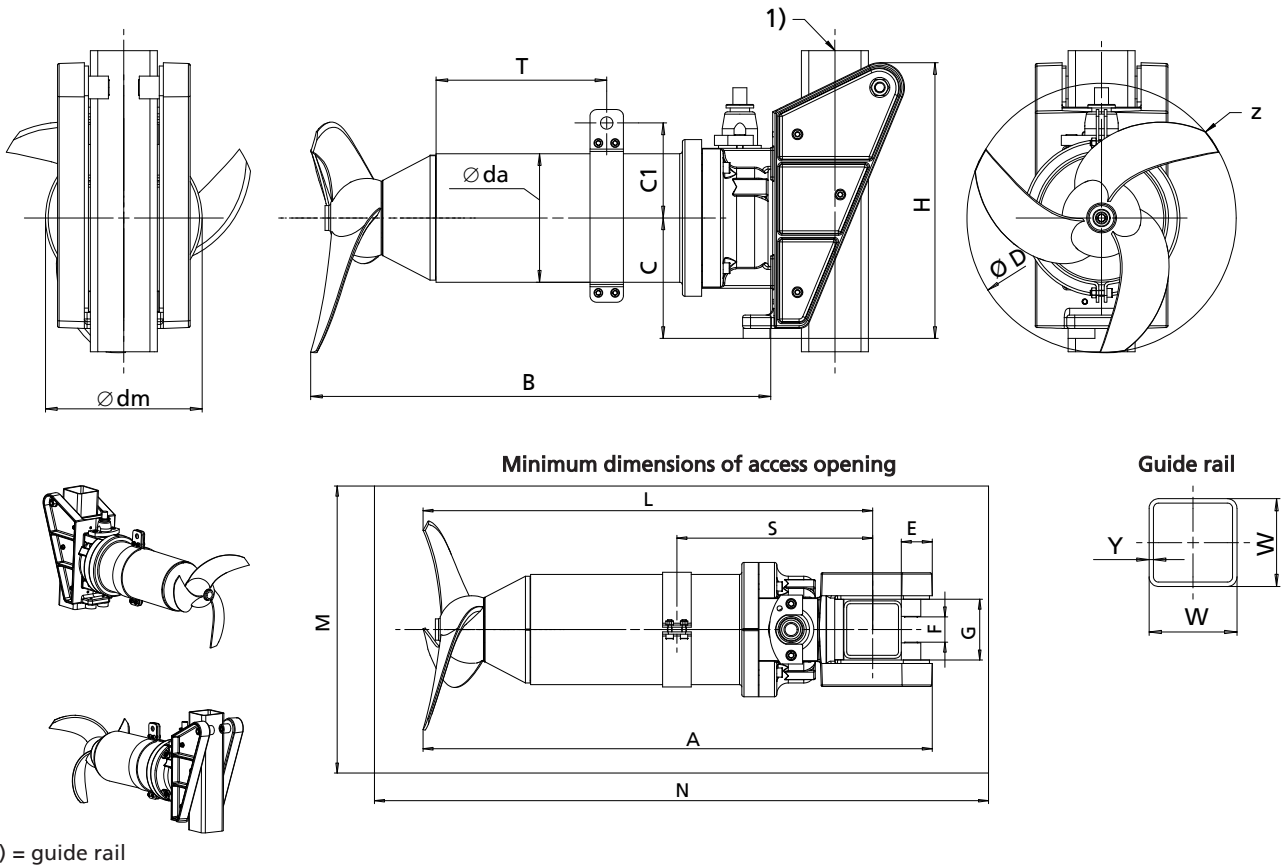

Technical data

Size	P ₂ [kW]	[kg] ¹¹⁾	z ¹²⁾	Guide rail	
				W [mm]	Y [mm]
V 2227 / 1 4 UDG / YDG	1,25	35	2	60	3
V 2227 / 2 4 UDG / YDG	2,5	37,7	2	60	3
V 2230 / 2 4 UDG / YDG	2,5	37,7	3	60	3
V 2235 / 2 4 UDG / YDG	2,5	37,7	3	60	3
C 2227 / 1 4 UDG / YDG	2,5	37,7	2	60	3
C 2227 / 2 4 UDG / YDG	2,5	37,7	2	60	3
C 2223 / 2 4 UDG / YDG	2,5	37,7	2	60	3
C 2233 / 2 4 UDG / YDG	2,5	37,7	3	60	3

Dimensions [mm]

Size	A	B	C	C1	∅ D	∅ da	∅ dm	E	F	G	H	L	M	N	S	T
V 2227 / 1 4 UDG / YDG	596	459	150	124	~225	156	187	42	36	66	287	524	225	780	210	240
V 2227 / 2 4 UDG / YDG	596	459	150	124	~225	156	187	42	36	66	287	524	225	780	215	235
V 2230 / 2 4 UDG / YDG	596	459	150	124	~225	156	187	42	36	66	287	524	275	780	215	235
V 2235 / 2 4 UDG / YDG	596	459	150	124	~225	156	187	42	36	66	287	524	275	780	215	235
C 2227 / 1 4 UDG / YDG	596	459	150	124	~225	156	187	42	36	66	287	524	225	780	215	235
C 2227 / 2 4 UDG / YDG	596	459	150	124	~225	156	187	42	36	66	287	524	225	780	215	235
C 2223 / 2 4 UDG / YDG	596	459	150	124	~225	156	187	42	36	66	287	524	225	780	215	235
C 2233 / 2 4 UDG / YDG	596	459	150	124	~225	156	187	42	36	66	287	524	275	780	215	235

11) Incl. 10-metre power cable and guide bracket

12) z = number of blades

Amamix 200, 400 V, 50 Hz, n = 1400 rpm, material variant C - version without jet ring

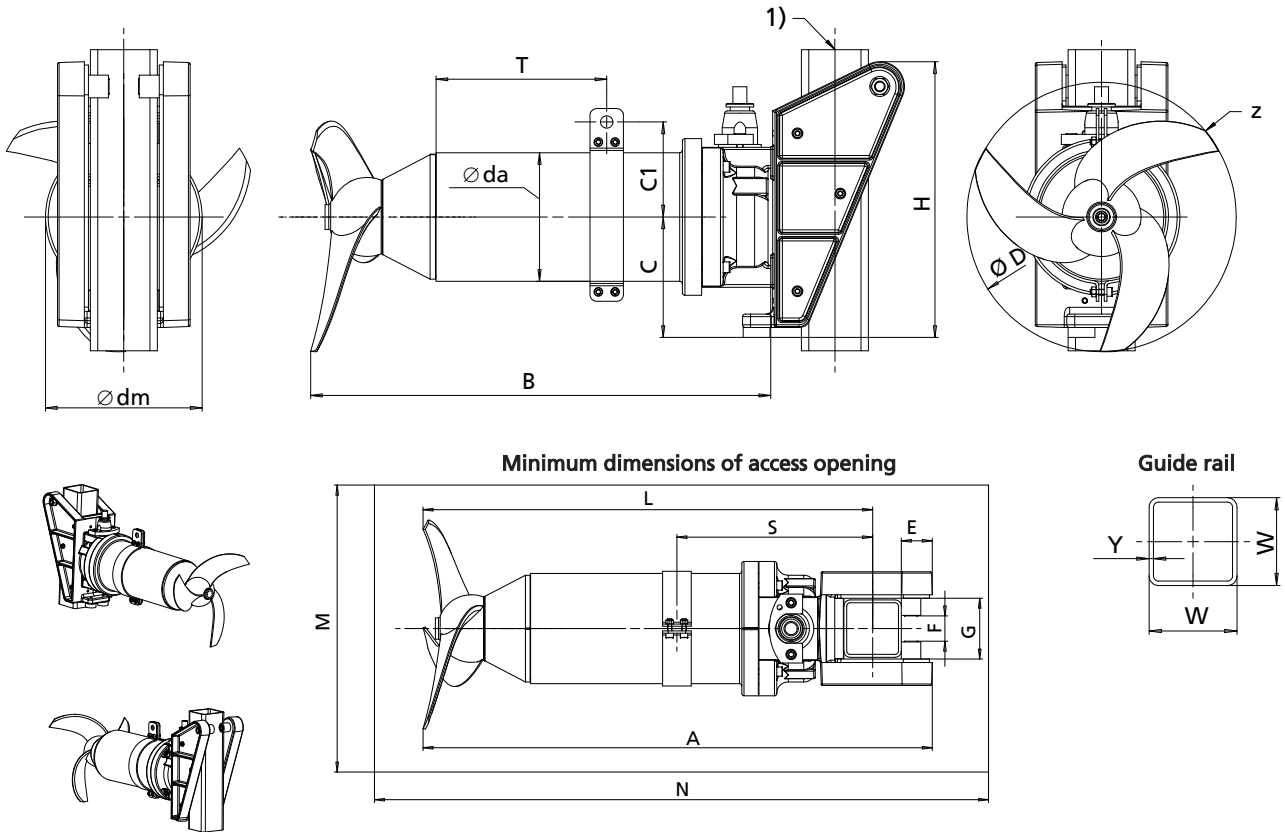

1) = guide rail

Technical data

Size	P ₂ [kW]	[kg] ¹³⁾	z ¹⁴⁾	Guide rail	
				W [mm]	Y [mm]
C 2227 / 1 4 UDC / YDC	1,25	34	2	60	3
C 2227 / 2 4 UDC / YDC	2,5	36,5	2	60	3
C 2223 / 2 4 UDC / YDC	2,5	36,5	2	60	3
C 2233 / 2 4 UDC / YDC	2,5	36,5	3	60	3

Dimensions [mm]

Size	A	B	C	C1	∅ D	∅ da	∅ dm	E	F	G	H	L	M	N	S	T
C 2227 / 1 4 UDC / YDC	592	459	150	120	~225	148	187	42	36	66	287	520	225	780	220	200
C 2227 / 2 4 UDC / YDC	592	459	150	120	~225	148	187	42	36	66	287	520	225	780	225	195
C 2223 / 2 4 UDC / YDC	592	459	150	120	~225	148	187	42	36	66	287	520	225	780	225	195
C 2233 / 2 4 UDC / YDC	592	459	150	120	~225	148	187	42	36	66	287	520	275	780	225	195

¹³⁾ Incl. 10-metre power cable and guide bracket

¹⁴⁾ z = number of blades

Amamix 300, 400 V, 50 Hz, n = 920 rpm, material variant G - version without jet ring

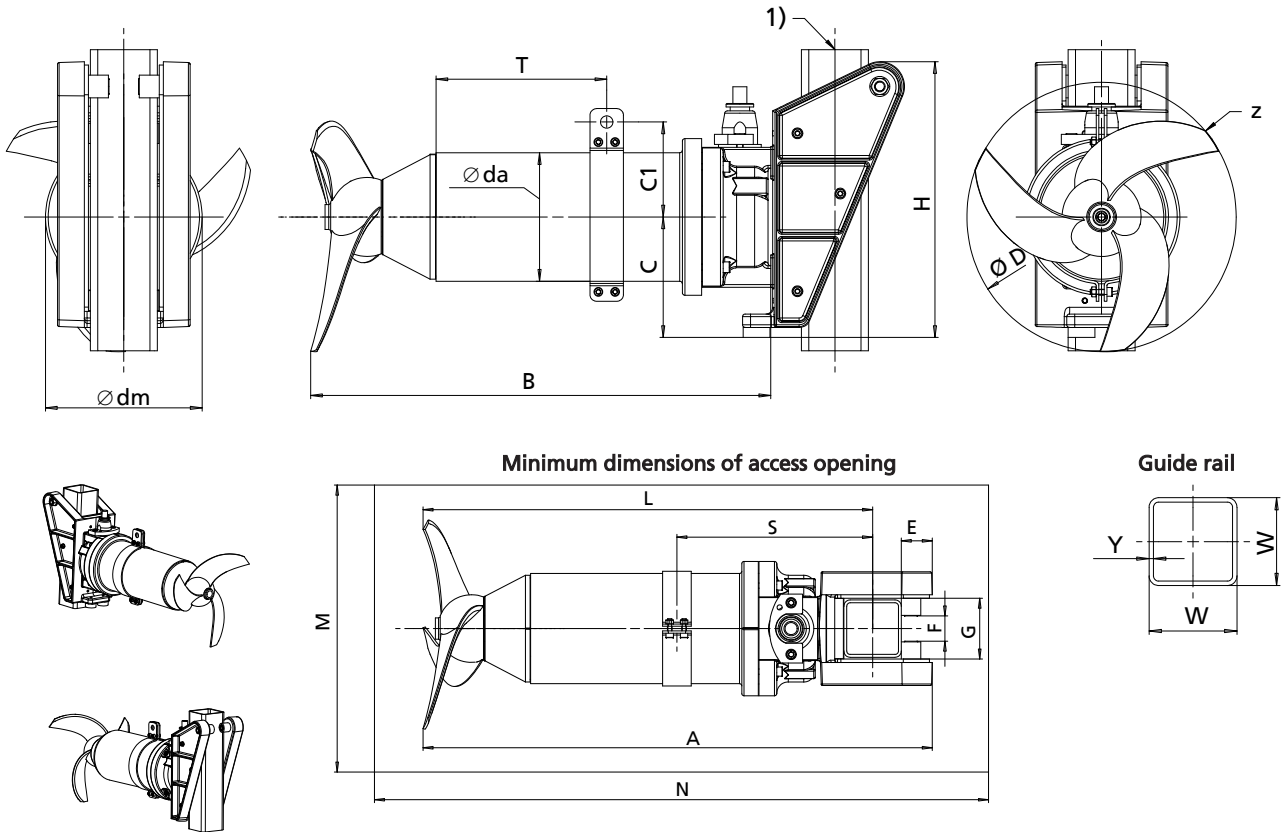

1) = guide rail

Technical data

Size	P ₂ [kW]	[kg] ¹⁵⁾	z ¹⁶⁾	Guide rail	
				W [mm]	Y [mm]
C 2925 / 0 6 UDG / YDG	1,8	53,5	2	60	3
C 2928 / 0 6 UDG / YDG	1,8	53,5	2	60	3
C 3225 / 0 6 UDG / YDG	1,8	53,5	2	60	3
C 3228 / 0 6 UDG / YDG	1,8	53,5	2	60	3
C 2936 / 0 6 UDG / YDG	1,8	53,5	3	60	3
C 2938 / 0 6 UDG / YDG	1,8	53,5	3	60	3
C 2925 / 2 6 UDG / YDG	3,2	53,5	2	60	3
C 2928 / 2 6 UDG / YDG	3,2	53,5	2	60	3
C 3225 / 2 6 UDG / YDG	3,2	53,5	2	60	3
C 3228 / 2 6 UDG / YDG	3,2	53,5	2	60	3
C 2936 / 2 6 UDG / YDG	3,2	53,5	3	60	3
C 2938 / 2 6 UDG / YDG	3,2	53,5	3	60	3
C 3236 / 2 6 UDG / YDG	3,2	53,5	3	60	3
C 3238 / 2 6 UDG / YDG	3,2	53,5	3	60	3
C 2931 / 2 6 UDG / YDG	3,2	53,5	3	60	3
C 2935 / 2 6 UDG / YDG	3,2	53,5	3	60	3
C 3231 / 2 6 UDG / YDG	3,2	53,5	3	60	3

Dimensions [mm]

Size	A	B	C	C1	$\varnothing D$	$\varnothing da$	$\varnothing dm$	E	F	G	H	L	M	N	S	T
C 2925 / 0 6 UDG / YDG	731	594	150	124	294	156	187	42	36	66	287	659	275	910	268	230
C 2928 / 0 6 UDG / YDG	731	594	150	124	294	156	187	42	36	66	287	659	275	910	268	230
C 3225 / 0 6 UDG / YDG	731	594	150	124	325	156	187	42	36	66	287	659	275	910	268	230

¹⁵⁾ Incl. 10-metre power cable and guide bracket

¹⁶⁾ z = number of blades

Size	A	B	C	C1	∅ D	∅ da	∅ dm	E	F	G	H	L	M	N	S	T
C 3228 / 0 6 UDG / YDG	731	594	150	124	325	156	187	42	36	66	287	659	275	910	268	230
C 2936 / 0 6 UDG / YDG	731	594	150	124	294	156	187	42	36	66	287	659	375	910	268	230
C 2938 / 0 6 UDG / YDG	731	594	150	124	294	156	187	42	36	66	287	659	375	910	268	230
C 2925 / 2 6 UDG / YDG	731	594	150	124	294	156	187	42	36	66	287	659	275	910	268	230
C 2928 / 2 6 UDG / YDG	731	594	150	124	294	156	187	42	36	66	287	659	275	910	268	230
C 3225 / 2 6 UDG / YDG	731	594	150	124	325	156	187	42	36	66	287	659	275	910	268	230
C 3228 / 2 6 UDG / YDG	731	594	150	124	325	156	187	42	36	66	287	659	275	910	268	230
C 2936 / 2 6 UDG / YDG	731	594	150	124	294	156	187	42	36	66	287	659	375	910	268	230
C 2938 / 2 6 UDG / YDG	731	594	150	124	294	156	187	42	36	66	287	659	375	910	268	230
C 3236 / 2 6 UDG / YDG	731	594	150	124	325	156	187	42	36	66	287	659	375	910	268	230
C 3238 / 2 6 UDG / YDG	731	594	150	124	325	156	187	42	36	66	287	659	375	910	268	230
C 2931 / 2 6 UDG / YDG	731	594	150	124	294	156	187	42	36	66	287	659	375	910	268	230
C 2935 / 2 6 UDG / YDG	731	594	150	124	294	156	187	42	36	66	287	659	375	910	268	230
C 3231 / 2 6 UDG / YDG	731	594	150	124	325	156	187	42	36	66	287	659	375	910	268	230

Amamix 300, 400 V, 50 Hz, n = 920 rpm, material variant C - version without jet ring

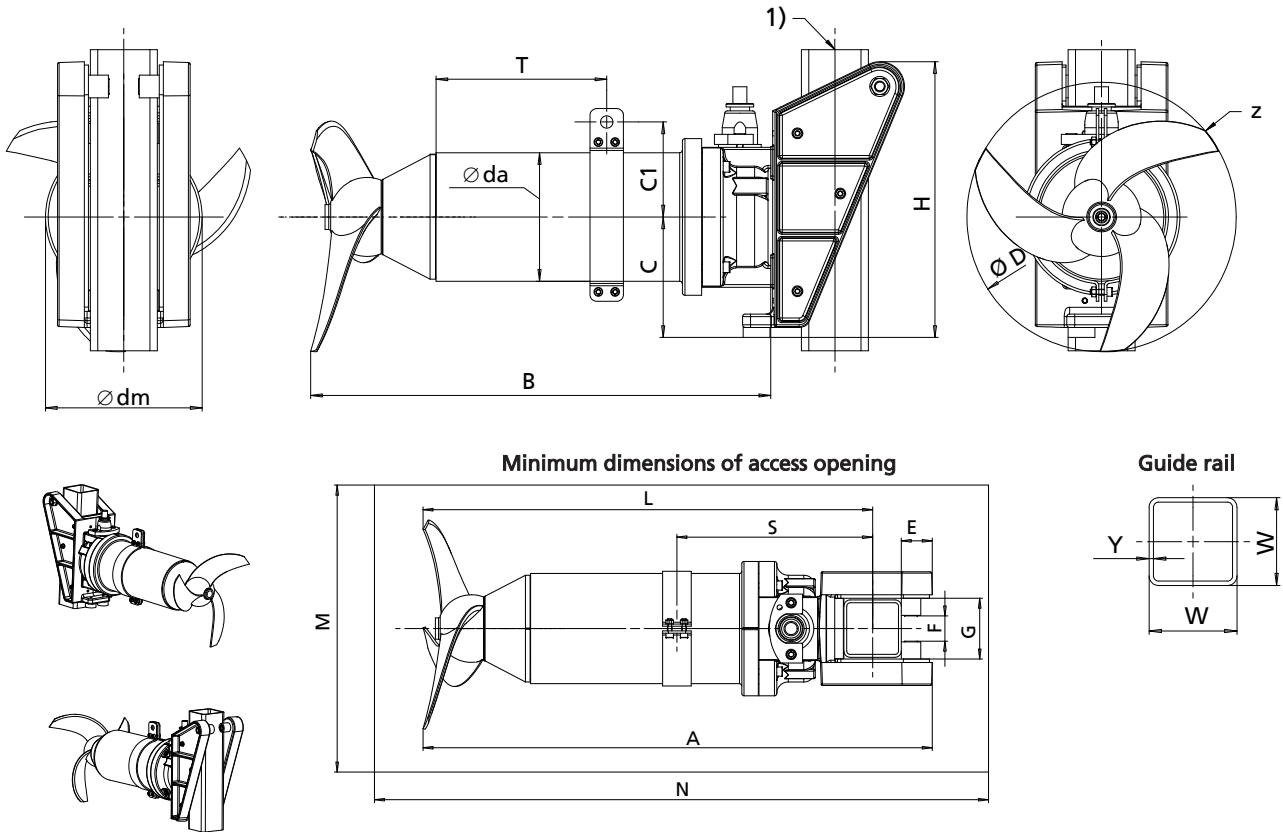

1) = guide rail

Technical data

Size	P ₂ [kW]	[kg] ¹⁷⁾	z ¹⁸⁾	Guide rail	
				W [mm]	Y [mm]
C 2925 / 0 6 UDC / YDC	1,8	47	2	60	3
C 2928 / 0 6 UDC / YDC	1,8	47	2	60	3
C 3225 / 0 6 UDC / YDC	1,8	47	2	60	3
C 3228 / 0 6 UDC / YDC	1,8	47	2	60	3
C 2936 / 0 6 UDC / YDG	1,8	47	3	60	3
C 2938 / 0 6 UDC / YDC	1,8	47	3	60	3
C 2925 / 2 6 UDC / YDC	3,2	47	2	60	3
C 2928 / 2 6 UDC / YDC	3,2	47	2	60	3
C 3225 / 2 6 UDC / YDC	3,2	47	2	60	3
C 3228 / 2 6 UDC / YDC	3,2	47	2	60	3
C 2936 / 2 6 UDC / YDC	3,2	47	3	60	3
C 2938 / 2 6 UDC / YDC	3,2	47	3	60	3
C 3236 / 2 6 UDC / YDC	3,2	47	3	60	3
C 3238 / 2 6 UDC / YDC	3,2	47	3	60	3
C 2931 / 2 6 UDC / YDC	3,2	47	3	60	3
C 2935 / 2 6 UDC / YDC	3,2	47	3	60	3
C 3231 / 2 6 UDC / YDC	3,2	47	3	60	3

Dimensions [mm]

Size	A	B	C	C1	$\varnothing D$	$\varnothing da$	$\varnothing dm$	E	F	G	H	L	M	N	S	T
C 2925 / 0 6 UDC / YDC	727	594	150	120	294	148	187	42	36	66	287	655	275	910	264	230
C 2928 / 0 6 UDC / YDC	727	594	150	120	294	148	187	42	36	66	287	655	275	910	264	230
C 3225 / 0 6 UDC / YDC	727	594	150	120	325	148	187	42	36	66	287	655	275	910	264	230

¹⁷⁾ Incl. 10-metre power cable and guide bracket

¹⁸⁾ z = number of blades

Size	A	B	C	C1	∅ D	∅ da	∅ dm	E	F	G	H	L	M	N	S	T
C 3228 / 0 6 UDC / YDC	727	594	150	120	325	148	187	42	36	66	287	655	275	910	264	230
C 2936 / 0 6 UDC / YDG	727	594	150	120	294	148	187	42	36	66	287	655	375	910	264	230
C 2938 / 0 6 UDC / YDC	727	594	150	120	294	148	187	42	36	66	287	655	375	910	264	230
C 2925 / 2 6 UDC / YDC	727	594	150	120	294	148	187	42	36	66	287	655	275	910	264	230
C 2928 / 2 6 UDC / YDC	727	594	150	120	294	148	187	42	36	66	287	655	275	910	264	230
C 3225 / 2 6 UDC / YDC	727	594	150	120	325	148	187	42	36	66	287	655	275	910	264	230
C 3228 / 2 6 UDC / YDC	727	594	150	120	325	148	187	42	36	66	287	655	275	910	264	230
C 2936 / 2 6 UDC / YDC	727	594	150	120	294	148	187	42	36	66	287	655	375	910	264	230
C 2938 / 2 6 UDC / YDC	727	594	150	120	294	148	187	42	36	66	287	655	375	910	264	230
C 3236 / 2 6 UDC / YDC	727	594	150	120	325	148	187	42	36	66	287	655	375	910	264	230
C 3238 / 2 6 UDC / YDC	727	594	150	120	325	148	187	42	36	66	287	655	375	910	264	230
C 2931 / 2 6 UDC / YDC	727	594	150	120	294	148	187	42	36	66	287	655	375	910	264	230
C 2935 / 2 6 UDC / YDC	727	594	150	120	294	148	187	42	36	66	287	655	375	910	264	230
C 3231 / 2 6 UDC / YDC	727	594	150	120	325	148	187	42	36	66	287	655	375	910	264	230

Amamix 400, 400 V, 50 Hz, n = 700 rpm, material variant G - version without jet ring

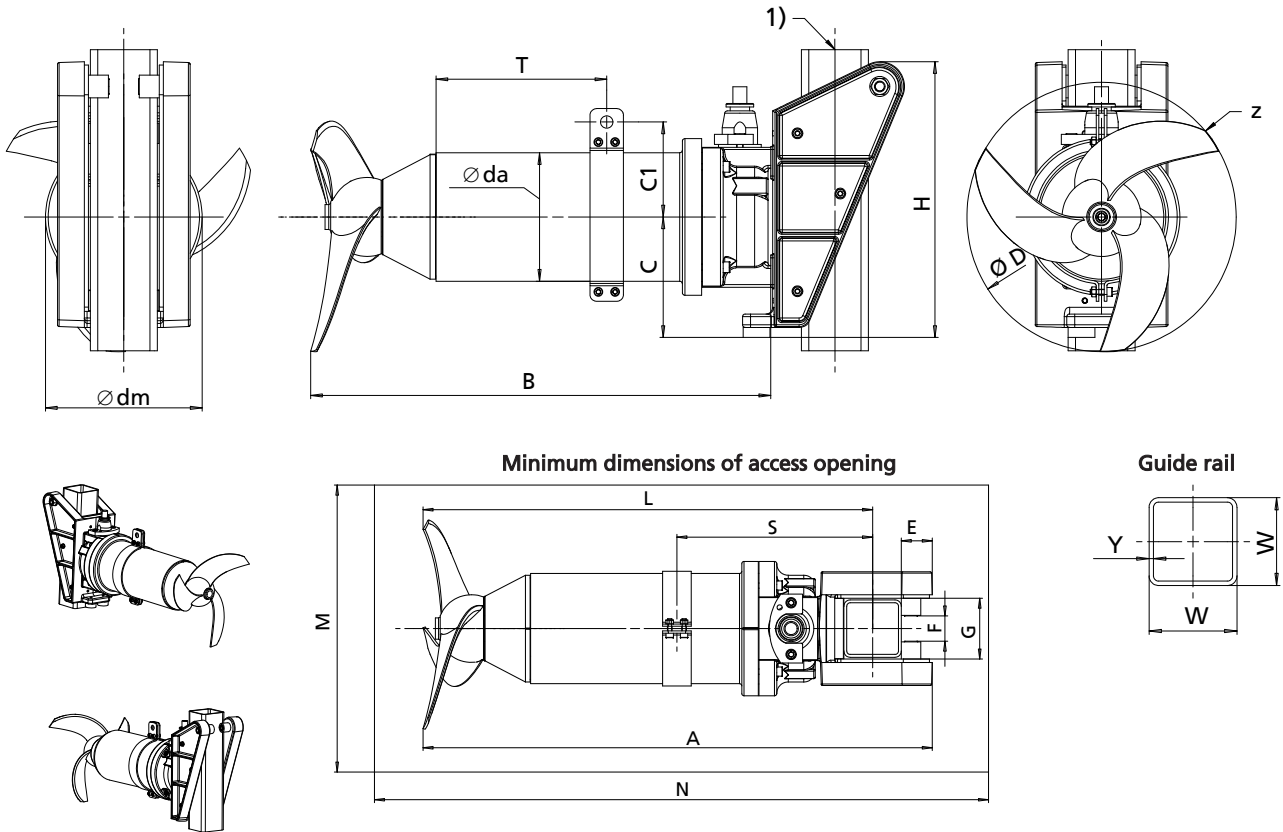

1) = guide rail

Technical data

Size	P ₂ [kW]	[kg] ¹⁹⁾	z ²⁰⁾	Guide rail	
				W [mm]	Y [mm]
C 3725 / 3 8 UDG / YDG	2,5	83	2	60	3
C 3728 / 3 8 UDG / YDG	2,5	83	2	60	3
C 4125 / 3 8 UDG / YDG	2,5	83	2	60	3
C 4128 / 3 8 UDG / YDG	2,5	83	2	60	3
C 3738 / 3 8 UDG / YDG	2,5	83	3	60	3
C 4138 / 3 8 UDG / YDG	2,5	83	3	60	3
C 3725 / 4 8 UDG / YDG	4	83	2	60	3
C 3728 / 4 8 UDG / YDG	4	83	2	60	3
C 4125 / 4 8 UDG / YDG	4	83	2	60	3
C 4128 / 4 8 UDG / YDG	4	83	2	60	3
C 3738 / 4 8 UDG / YDG	4	83	3	60	3
C 4138 / 4 8 UDG / YDG	4	83	3	60	3
C 3731 / 4 8 UDG / YDG	4	83	3	60	3
C 3735 / 4 8 UDG / YDG	4	83	3	60	3
C 4131 / 4 8 UDG / YDG	4	83	3	60	3
C 4135 / 4 8 UDG / YDG	4	91	3	100	5

Dimensions [mm]

Size	A	B	C	C1	∅ D	∅ da	∅ dm	E	F	G	H	L	M	N	S	T
C 3725 / 3 8 UDG / YDG	844	687	100	142	373	192	234	42	36	66	287	772	285	1050	321	275
C 3728 / 3 8 UDG / YDG	844	687	100	142	373	192	234	42	36	66	287	772	285	1050	321	275
C 4125 / 3 8 UDG / YDG	844	687	100	142	410	192	234	42	36	66	287	772	285	1050	321	275
C 4128 / 3 8 UDG / YDG	844	687	100	142	410	192	234	42	36	66	287	772	285	1050	321	275

¹⁹⁾ Incl. 10-metre power cable and guide bracket

²⁰⁾ z = number of blades

Size	A	B	C	C1	∅ D	∅ da	∅ dm	E	F	G	H	L	M	N	S	T
C 3738 / 3 8 UDG / YDG	844	687	100	142	373	192	234	42	36	66	287	772	460	1050	321	275
C 4138 / 3 8 UDG / YDG	844	687	100	142	410	192	234	42	36	66	287	772	460	1050	321	275
C 3725 / 4 8 UDG / YDG	844	687	100	142	373	192	234	42	36	66	287	772	285	1050	321	275
C 3728 / 4 8 UDG / YDG	844	687	100	142	373	192	234	42	36	66	287	772	285	1050	321	275
C 4125 / 4 8 UDG / YDG	844	687	100	142	410	192	234	42	36	66	287	772	285	1050	321	275
C 4128 / 4 8 UDG / YDG	844	687	100	142	410	192	234	42	36	66	287	772	285	1050	321	275
C 3738 / 4 8 UDG / YDG	844	687	100	142	373	192	234	42	36	66	287	772	460	1050	321	275
C 4138 / 4 8 UDG / YDG	844	687	100	142	410	192	234	42	36	66	287	772	460	1050	321	275
C 3731 / 4 8 UDG / YDG	844	687	100	142	373	192	234	42	36	66	287	772	460	1050	321	275
C 3735 / 4 8 UDG / YDG	844	687	100	142	373	192	234	42	36	66	287	772	460	1050	321	275
C 4131 / 4 8 UDG / YDG	844	687	100	142	410	192	234	42	36	66	287	772	460	1050	321	275
C 4135 / 4 8 UDG / YDG	876	687	180	142	410	192	234	43	44	106	412	783	460	1150	321	275

Amamix 400, 400 V, 50 Hz, n = 700 rpm, material variant C - version without jet ring

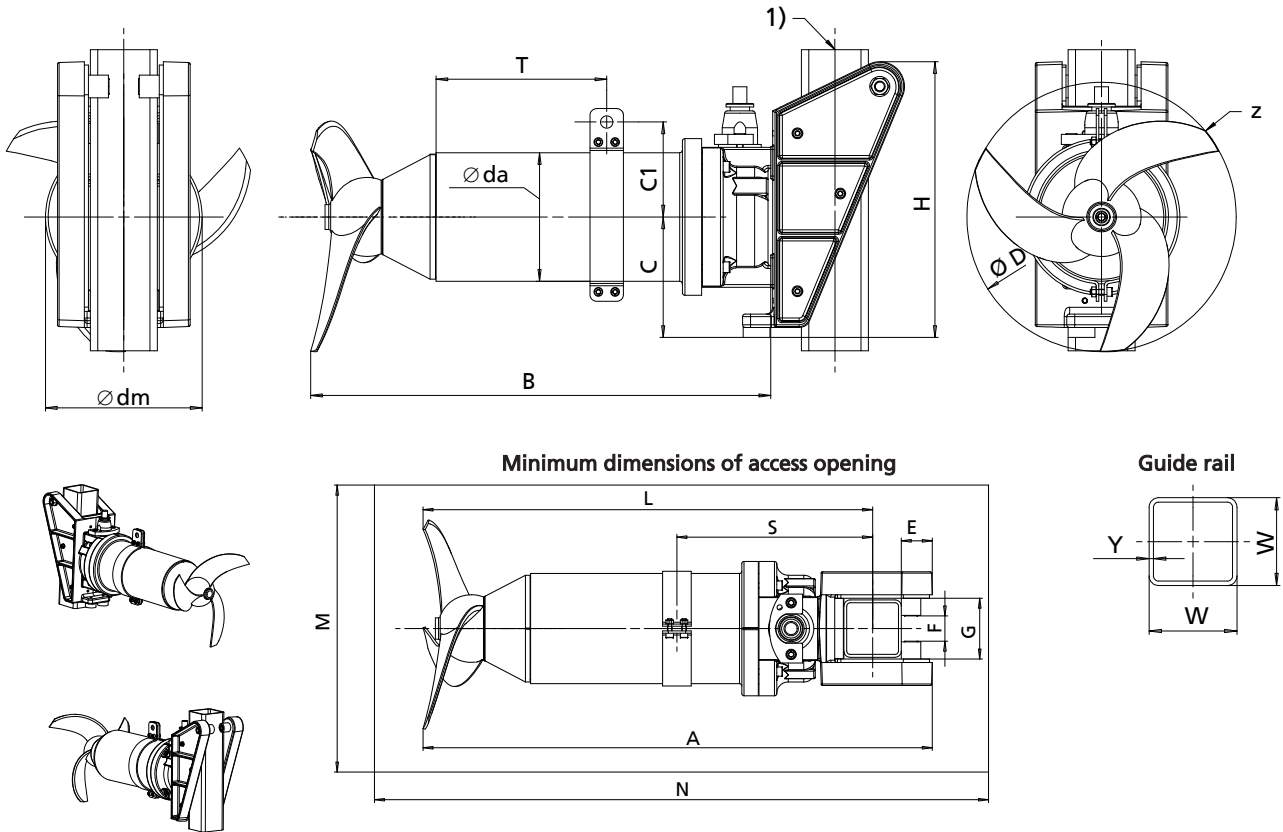

1) = guide rail

Technical data

Size	P ₂ [kW]	[kg] ²¹⁾	z ²²⁾	Guide rail	
				W [mm]	Y [mm]
C 3725 / 3 8 UDC / YDC	2,5	82,5	2	60	3
C 3728 / 3 8 UDC / YDC	2,5	82,5	2	60	3
C 4125 / 3 8 UDC / YDC	2,5	82,5	2	60	3
C 4128 / 3 8 UDC / YDC	2,5	82,5	2	60	3
C 3738 / 3 8 UDC / YDC	2,5	82,5	3	60	3
C 4138 / 3 8 UDC / YDC	2,5	82,5	3	60	3
C 3725 / 4 8 UDC / YDC	4	82,5	2	60	3
C 3728 / 4 8 UDC / YDC	4	82,5	2	60	3
C 4125 / 4 8 UDC / YDC	4	82,5	2	60	3
C 4128 / 4 8 UDC / YDC	4	82,5	2	60	3
C 3738 / 4 8 UDC / YDC	4	82,5	3	60	3
C 4138 / 4 8 UDC / YDC	4	82,5	3	60	3
C 3731 / 4 8 UDC / YDC	4	82,5	3	60	3
C 3735 / 4 8 UDC / YDC	4	82,5	3	60	3
C 4131 / 4 8 UDC / YDC	4	82,5	3	60	3
C 4135 / 4 8 UDC / YDC	4	84	3	100	5

Dimensions [mm]

Size	A	B	C	C1	∅ D	∅ da	∅ dm	E	F	G	H	L	M	N	S	T
C 3725 / 3 8 UDC / YDC	844	687	150	139	373	186	234	42	36	66	287	772	285	1050	318	275
C 3728 / 3 8 UDC / YDC	844	687	150	139	373	186	234	42	36	66	287	772	285	1050	318	275
C 4125 / 3 8 UDC / YDC	844	687	150	139	410	186	234	42	36	66	287	772	285	1050	318	275
C 4128 / 3 8 UDC / YDC	844	687	150	139	410	186	234	42	36	66	287	772	285	1050	318	275

21) Incl. 10-metre power cable and guide bracket

22) z = number of blades

Size	A	B	C	C1	∅ D	∅ da	∅ dm	E	F	G	H	L	M	N	S	T
C 3738 / 3 8 UDC / YDC	844	687	150	139	373	186	234	42	36	66	287	772	460	1050	318	275
C 4138 / 3 8 UDC / YDC	844	687	150	139	410	186	234	42	36	66	287	772	460	1050	318	275
C 3725 / 4 8 UDC / YDC	844	687	150	139	373	186	234	42	36	66	287	772	285	1050	318	275
C 3728 / 4 8 UDC / YDC	844	687	150	139	373	186	234	42	36	66	287	772	285	1050	318	275
C 4125 / 4 8 UDC / YDC	844	687	150	139	410	186	234	42	36	66	287	772	285	1050	318	275
C 4128 / 4 8 UDC / YDC	844	687	150	139	410	186	234	42	36	66	287	772	285	1050	318	275
C 3738 / 4 8 UDC / YDC	844	687	150	139	373	186	234	42	36	66	287	772	460	1050	318	275
C 4138 / 4 8 UDC / YDC	844	687	150	139	410	186	234	42	36	66	287	772	460	1050	318	275
C 3731 / 4 8 UDC / YDC	844	687	150	139	373	186	234	42	36	66	287	772	460	1050	318	275
C 3735 / 4 8 UDC / YDC	844	687	150	139	373	186	234	42	36	66	287	772	460	1050	318	275
C 4131 / 4 8 UDC / YDC	844	687	150	139	410	186	234	42	36	66	287	772	460	1050	318	275
C 4135 / 4 8 UDC / YDC	873	687	180	139	410	186	234	43	44	106	420	780	460	1150	318	275

Amamix 600, 400 V, 50 Hz, n = 475 rpm, material variant G - version without jet ring

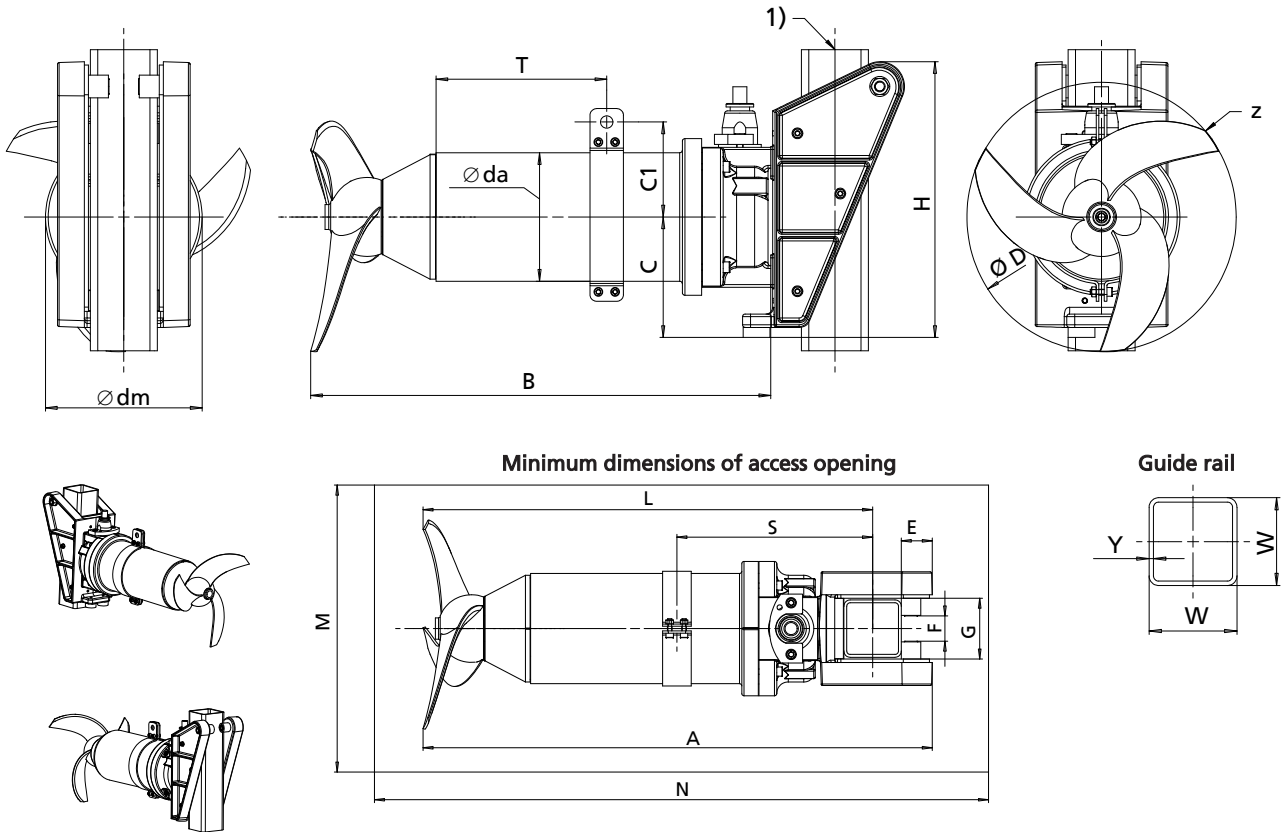

1) = guide rail

Technical data

Size	P ₂ [kW]	[kg] ²³⁾	z ²⁴⁾	Guide rail	
				W [mm]	Y [mm]
C 5725 / 6 12 UDG / YDG	5	221	2	100	5
C 5728 / 6 12 UDG / YDG	5	221	2	100	5
C 6325 / 6 12 UDG / YDG	5	221	2	100	5
C 6328 / 6 12 UDG / YDG	5	221	2	100	5
C 5725 / 10 12 UDG / YDG	10	235	2	100	5
C 5728 / 10 12 UDG / YDG	10	235	2	100	5
C 6325 / 10 12 UDG / YDG	10	235	2	100	5
C 6328 / 10 12 UDG / YDG	10	235	2	100	5
C 5738 / 10 12 UDG / YDG	10	235	3	100	5
C 6338 / 10 12 UDG / YDG	10	235	3	100	5
C 5731 / 10 12 UDG / YDG	10	235	3	100	5
C 5735 / 10 12 UDG / YDG	10	235	3	100	5
C 6331 / 10 12 UDG / YDG	10	235	3	100	5
C 6335 / 10 12 UDG / YDG	10	235	3	100	5

Dimensions [mm]

Size	A	B	C	C1	Ø D	Ø da	Ø dm	E	F	G	H	L	M	N	S	T
C 5725 / 6 12 UDG / YDG	1042	848	230	197	570	294	380	43	44	106	508	949	450	1310	393	280
C 5728 / 6 12 UDG / YDG	1042	848	230	197	570	294	380	43	44	106	508	949	450	1310	393	280
C 6325 / 6 12 UDG / YDG	1042	848	230	197	630	294	380	43	44	106	508	949	450	1310	393	280
C 6328 / 6 12 UDG / YDG	1042	848	230	197	630	294	380	43	44	106	508	949	450	1310	393	280
C 5725 / 10 12 UDG / YDG	1042	848	230	197	570	294	380	43	44	106	508	949	450	1310	393	280
C 5728 / 10 12 UDG / YDG	1042	848	230	197	570	294	380	43	44	106	508	949	450	1310	393	280

²³⁾ Incl. 10-metre power cable and guide bracket

²⁴⁾ z = number of blades

Size	A	B	C	C1	∅ D	∅ da	∅ dm	E	F	G	H	L	M	N	S	T
C 6325 / 10 12 UDG / YDG	1042	848	230	197	630	294	380	43	44	106	508	949	450	1310	393	280
C 6328 / 10 12 UDG / YDG	1042	848	230	197	630	294	380	43	44	106	508	949	450	1310	393	280
C 5738 / 10 12 UDG / YDG	1042	848	230	197	570	294	380	43	44	106	508	949	700	1310	393	280
C 6338 / 10 12 UDG / YDG	1042	848	230	197	630	294	380	43	44	106	508	949	700	1310	393	280
C 5731 / 10 12 UDG / YDG	1042	848	230	197	570	294	380	43	44	106	508	949	700	1310	393	280
C 5735 / 10 12 UDG / YDG	1042	848	230	197	570	294	380	43	44	106	508	949	700	1310	393	280
C 6331 / 10 12 UDG / YDG	1042	848	230	197	630	294	380	43	44	106	508	949	700	1310	393	280
C 6335 / 10 12 UDG / YDG	1042	848	230	197	630	294	380	43	44	106	508	949	700	1310	393	280

Amamix 600, 400 V, 50 Hz, n = 475 rpm, material variant C - version without jet ring

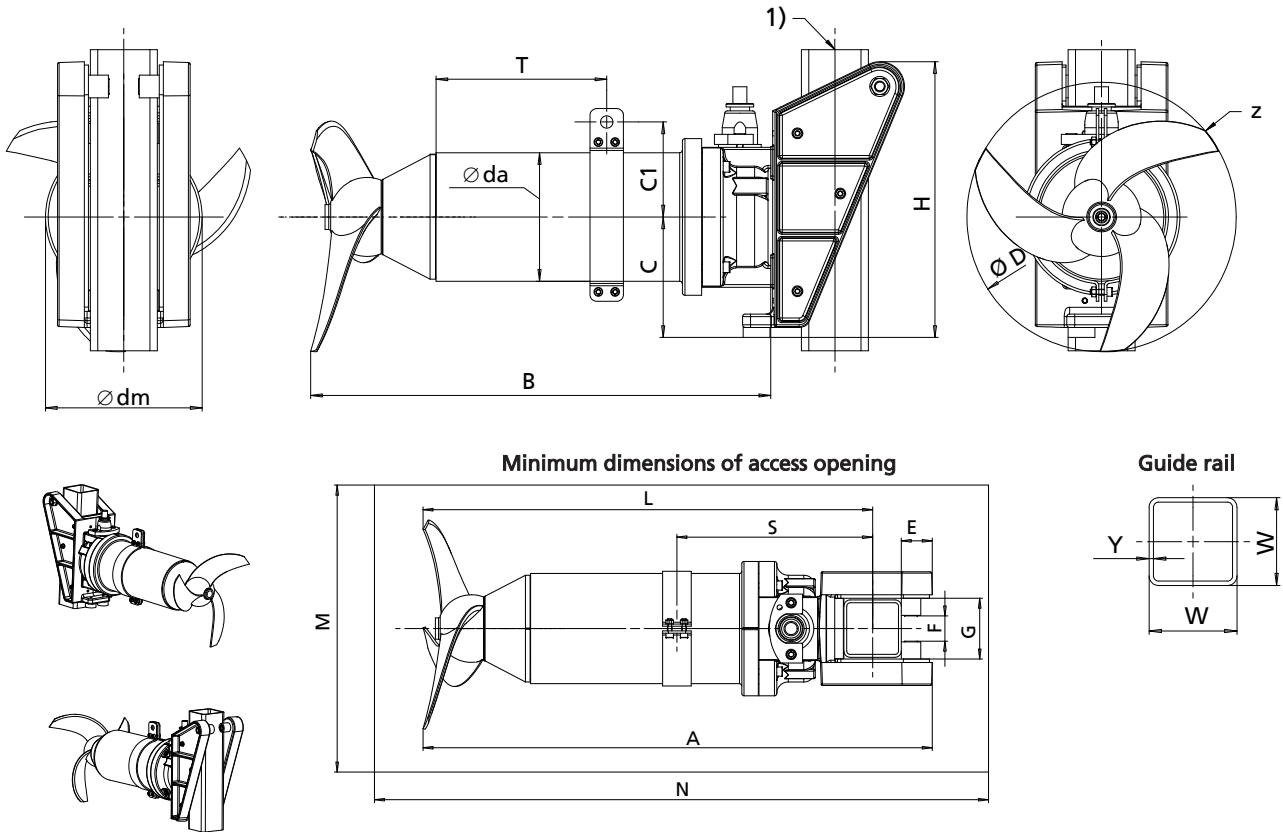

1) = guide rail

Technical data

Size	P ₂ [kW]	[kg] ²⁵⁾	z ²⁶⁾	Guide rail	
				W [mm]	Y [mm]
C 5725 / 4 12 UMC / YMC	5	146	2	100	5
C 5728 / 4 12 UMC / YMC	5	146	2	100	5
C 6325 / 4 12 UMC / YMC	5	146	2	100	5
C 6328 / 4 12 UMC / YMC	5	146	2	100	5
C 5725 / 8 12 UMC / YMC	10	198	2	100	5
C 5728 / 8 12 UMC / YMC	10	198	2	100	5
C 6325 / 8 12 UMC / YMC	10	198	2	100	5
C 6328 / 8 12 UMC / YMC	10	198	2	100	5
C 5738 / 8 12 UMC / YMC	10	198	3	100	5
C 6338 / 8 12 UMC / YMC	10	198	3	100	5
C 5731 / 8 12 UMC / YMC	10	198	3	100	5
C 5735 / 8 12 UMC / YMC	10	198	3	100	5
C 6331 / 8 12 UMC / YMC	10	198	3	100	5
C 6335 / 8 12 UMC / YMC	10	198	3	100	5

Dimensions [mm]

Size	A	B	C	C1	∅ D	∅ da	∅ dm	E	F	G	H	L	M	N	S	T
C 5725 / 4 12 UMC / YMC	1002	816	215	175	570	251	304	43	44	106	420	909	450	1270	360	275
C 5728 / 4 12 UMC / YMC	1002	816	215	175	570	251	304	43	44	106	420	909	450	1270	360	275
C 6325 / 4 12 UMC / YMC	1002	816	215	175	630	251	304	43	44	106	420	909	450	1270	360	275
C 6328 / 4 12 UMC / YMC	1002	816	215	175	630	251	304	43	44	106	420	909	450	1270	360	275
C 5725 / 8 12 UMC / YMC	1122	936	215	175	570	251	304	43	44	106	420	1029	450	1390	425	330
C 5728 / 8 12 UMC / YMC	1122	936	215	175	570	251	304	43	44	106	420	1029	450	1390	425	330

²⁵⁾ Incl. 10-metre power cable and guide bracket

²⁶⁾ z = number of blades

Size	A	B	C	C1	∅ D	∅ da	∅ dm	E	F	G	H	L	M	N	S	T
C 6325 / 8 12 UMC / YMC	1122	936	215	175	630	251	304	43	44	106	420	1029	450	1390	425	330
C 6328 / 8 12 UMC / YMC	1122	936	215	175	630	251	304	43	44	106	420	1029	450	1390	425	330
C 5738 / 8 12 UMC / YMC	1122	936	215	175	570	251	304	43	44	106	420	1029	700	1390	425	330
C 6338 / 8 12 UMC / YMC	1122	936	215	175	630	251	304	43	44	106	420	1029	700	1390	425	330
C 5731 / 8 12 UMC / YMC	1122	936	215	175	570	251	304	43	44	106	420	1029	700	1390	425	330
C 5735 / 8 12 UMC / YMC	1122	936	215	175	570	251	304	43	44	106	420	1029	700	1390	425	330
C 6331 / 8 12 UMC / YMC	1122	936	215	175	630	251	304	43	44	106	420	1029	700	1390	425	330
C 6335 / 8 12 UMC / YMC	1122	936	215	175	630	251	304	43	44	106	420	1029	700	1390	425	330

Amamix 300, 400 V, 50 Hz, n = 920 rpm, material variant G - version with jet ring

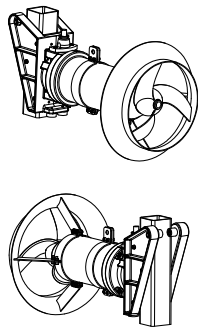
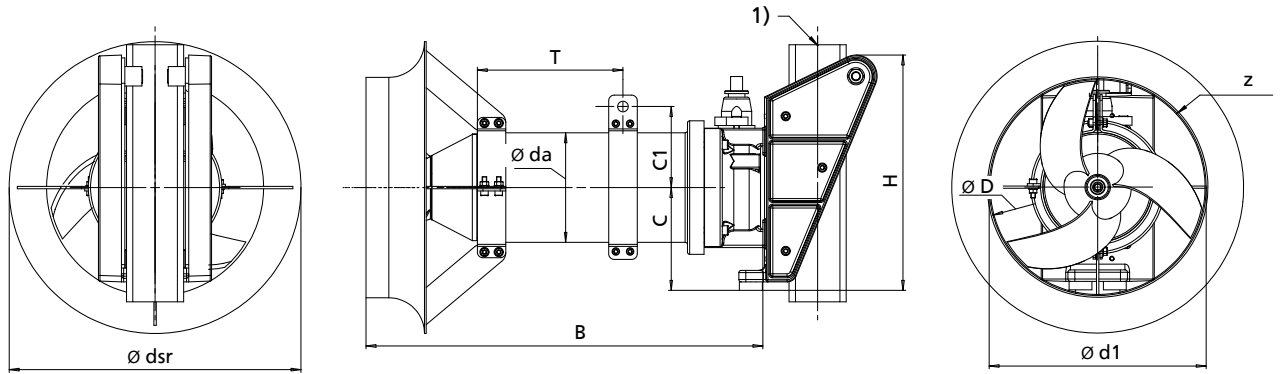

Minimum dimensions of access opening

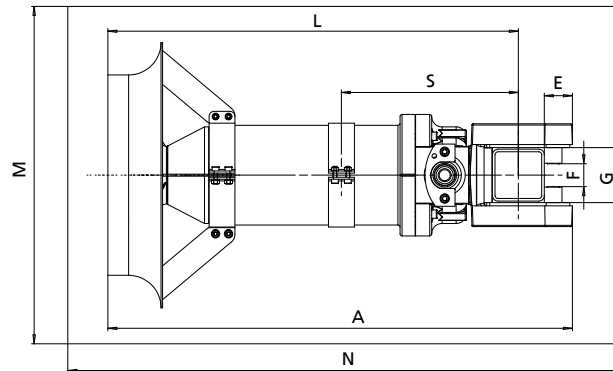

Guide rail

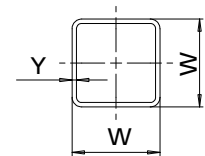

1) = guide rail

Technical data

Size	P ₂ [kW]	[kg] ²⁷⁾	z ²⁸⁾	Guide rail	
				W [mm]	Y [mm]
C 2925 R / 0 6 UDG / YDG	1,8	58,2	2	60	3
C 2928 R / 0 6 UDG / YDG	1,8	58,2	2	60	3
C 2936 R / 0 6 UDG / YDG	1,8	58,2	3	60	3
C 2938 R / 0 6 UDG / YDG	1,8	58,2	3	60	3
C 2925 R / 2 6 UDG / YDG	3,2	58,2	2	60	3
C 2928 R / 2 6 UDG / YDG	3,2	58,2	2	60	3
C 2936 R / 2 6 UDG / YDG	3,2	58,2	3	60	3
C 2938 R / 2 6 UDG / YDG	3,2	58,2	3	60	3
C 2931 R / 2 6 UDG / YDG	3,2	58,2	3	60	3
C 2935 R / 2 6 UDG / YDG	3,2	58,2	3	60	3

Dimensions [mm]

Size	A	B	C	C1	$\varnothing D$	$\varnothing da$	$\varnothing d1$	$\varnothing dsr$	E	F	G	H	L	M	N	S	T
C 2925 R / 0 6 UDG / YDG	735	598	150	124	294	156	300	400	42	36	66	287	663	500	945	278	220
C 2928 R / 0 6 UDG / YDG	735	598	150	124	294	156	300	400	42	36	66	287	663	500	945	278	220
C 2936 R / 0 6 UDG / YDG	735	598	150	124	294	156	300	400	42	36	66	287	663	500	945	278	220
C 2938 R / 0 6 UDG / YDG	735	598	150	124	294	156	300	400	42	36	66	287	663	500	945	278	220
C 2925 R / 2 6 UDG / YDG	735	598	150	124	294	156	300	400	42	36	66	287	663	500	945	278	220
C 2928 R / 2 6 UDG / YDG	735	598	150	124	294	156	300	400	42	36	66	287	663	500	945	278	220
C 2936 R / 2 6 UDG / YDG	735	598	150	124	294	156	300	400	42	36	66	287	663	500	945	278	220
C 2938 R / 2 6 UDG / YDG	735	598	150	124	294	156	300	400	42	36	66	287	663	500	945	278	220
C 2931 R / 2 6 UDG / YDG	735	598	150	124	294	156	300	400	42	36	66	287	663	500	945	278	220
C 2935 R / 2 6 UDG / YDG	735	598	150	124	294	156	300	400	42	36	66	287	663	500	945	278	220

27) Incl. 10-metre power cable and guide bracket

28) z = number of blades

Amamix 300, 400 V, 50 Hz, n = 920 rpm, material variant C - version with jet ring

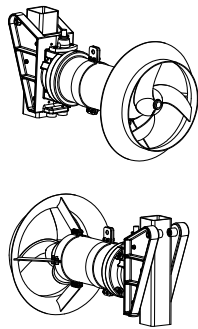
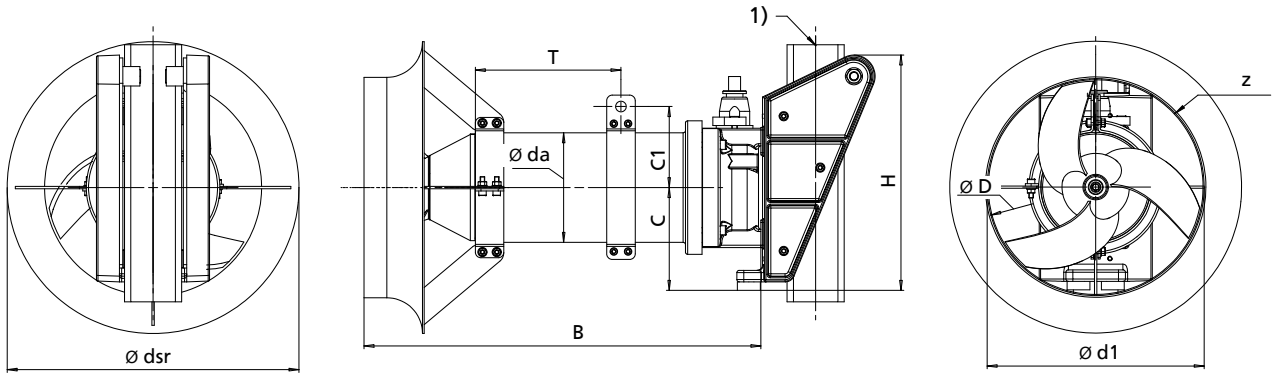

Minimum dimensions of access opening

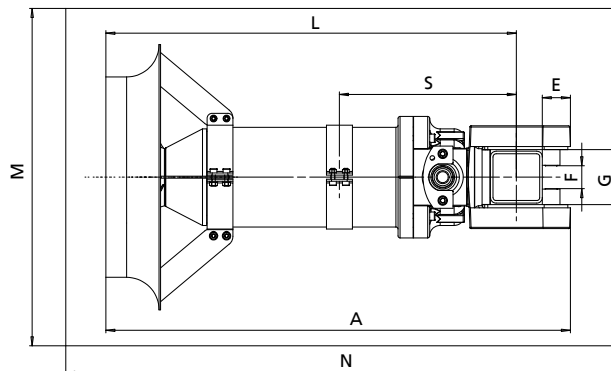

Guide rail

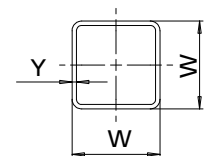

1) = guide rail

Technical data

Size	P ₂ [kW]	[kg] ²⁹⁾	z ³⁰⁾	Guide rail	
				W [mm]	Y [mm]
C 2925 R / 0 6 UDC / YDC	1,8	51,7	2	60	3
C 2928 R / 0 6 UDC / YDC	1,8	51,7	2	60	3
C 2936 R / 0 6 UDC / YDC	1,8	51,7	3	60	3
C 2938 R / 0 6 UDC / YDC	1,8	51,7	3	60	3
C 2925 R / 2 6 UDC / YDC	3,2	51,7	2	60	3
C 2928 R / 2 6 UDC / YDC	3,2	51,7	2	60	3
C 2936 R / 2 6 UDC / YDC	3,2	51,7	3	60	3
C 2938 R / 2 6 UDC / YDC	3,2	51,7	3	60	3
C 2931 R / 2 6 UDC / YDC	3,2	51,7	3	60	3
C 2935 R / 2 6 UDC / YDC	3,2	51,7	3	60	3

Dimensions [mm]

Size	A	B	C	C1	$\varnothing D$	$\varnothing da$	$\varnothing d1$	$\varnothing dsr$	E	F	G	H	L	M	N	S	T
C 2925 R / 0 6 UDC / YDC	731	598	150	120	294	148	300	400	42	36	66	287	659	500	945	274	220
C 2928 R / 0 6 UDC / YDC	731	598	150	120	294	148	300	400	42	36	66	287	659	500	945	274	220
C 2936 R / 0 6 UDC / YDC	731	598	150	120	294	148	300	400	42	36	66	287	659	500	945	274	220
C 2938 R / 0 6 UDC / YDC	731	598	150	120	294	148	300	400	42	36	66	287	659	500	945	274	220
C 2925 R / 2 6 UDC / YDC	731	598	150	120	294	148	300	400	42	36	66	287	659	500	945	274	220
C 2928 R / 2 6 UDC / YDC	731	598	150	120	294	148	300	400	42	36	66	287	659	500	945	274	220
C 2936 R / 2 6 UDC / YDC	731	598	150	120	294	148	300	400	42	36	66	287	659	500	945	274	220
C 2938 R / 2 6 UDC / YDC	731	598	150	120	294	148	300	400	42	36	66	287	659	500	945	274	220
C 2931 R / 2 6 UDC / YDC	731	598	150	120	294	148	300	400	42	36	66	287	659	500	945	274	220
C 2935 R / 2 6 UDC / YDC	731	598	150	120	294	148	300	400	42	36	66	287	659	500	945	274	220

²⁹⁾ Incl. 10-metre power cable and guide bracket

³⁰⁾ z = number of blades

Amamix 400, 400 V, 50 Hz, n = 700 rpm, material variant G - version with jet ring

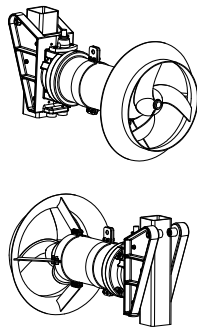
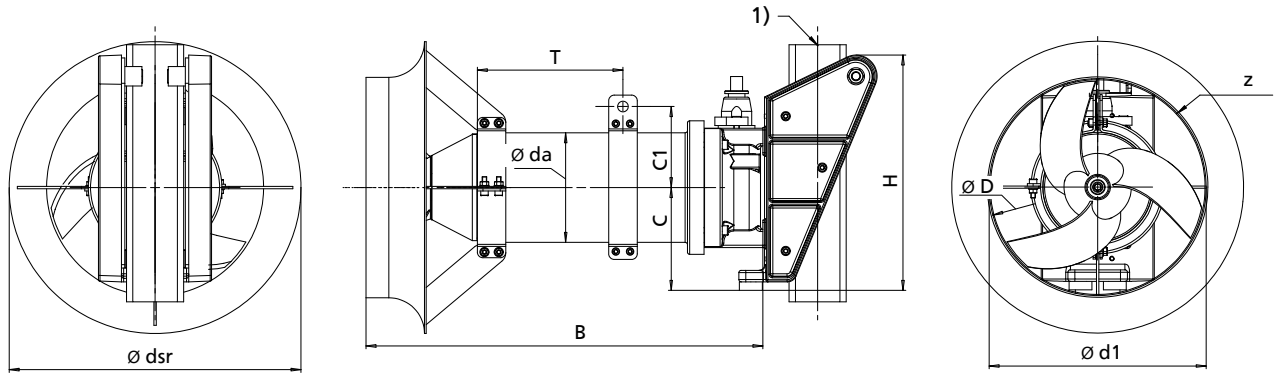

Minimum dimensions of access opening

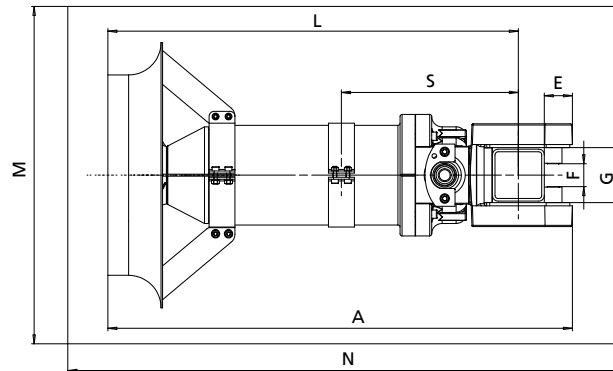

Guide rail

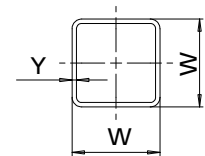

1) = guide rail

Technical data

Size	P ₂ [kW]	[kg] ³¹⁾	z ³²⁾	Guide rail	
				W [mm]	Y [mm]
C 3725 R / 3 8 UDG / YDG	2,5	89,8	2	60	3
C 3728 R / 3 8 UDG / YDG	2,5	89,8	2	60	3
C 3731 R / 3 8 UDG / YDG	2,5	89,8	3	60	3
C 3738 R / 3 8 UDG / YDG	2,5	89,8	3	60	3
C 3725 R / 4 8 UDG / YDG	4	89,8	2	60	3
C 3728 R / 4 8 UDG / YDG	4	89,8	2	60	3
C 3738 R / 4 8 UDG / YDG	4	89,8	3	60	3
C 3731 R / 4 8 UDG / YDG	4	89,8	3	60	3
C 3735 R / 4 8 UDG / YDG	4	89,8	3	60	3

Dimensions [mm]

Size	A	B	C	C1	$\varnothing D$	$\varnothing da$	$\varnothing d1$	$\varnothing dsr$	E	F	G	H	L	M	N	S	T
C 3725 R / 3 8 UDG / YDG	855	695	150	142	373	192	380	511	42	36	66	287	783	610	1050	341	255
C 3728 R / 3 8 UDG / YDG	855	695	150	142	373	192	380	511	42	36	66	287	783	610	1050	341	255
C 3731 R / 3 8 UDG / YDG	855	695	150	142	373	192	380	511	42	36	66	287	783	610	1050	341	255
C 3738 R / 3 8 UDG / YDG	855	695	150	142	373	192	380	511	42	36	66	287	783	610	1050	341	255
C 3725 R / 4 8 UDG / YDG	855	695	150	142	373	192	380	511	42	36	66	287	783	610	1050	341	255
C 3728 R / 4 8 UDG / YDG	855	695	150	142	373	192	380	511	42	36	66	287	783	610	1050	341	255
C 3738 R / 4 8 UDG / YDG	855	695	150	142	373	192	380	511	42	36	66	287	783	610	1050	341	255
C 3731 R / 4 8 UDG / YDG	855	695	150	142	373	192	380	511	42	36	66	287	783	610	1050	341	255
C 3735 R / 4 8 UDG / YDG	855	695	150	142	373	192	380	511	42	36	66	287	783	610	1050	341	255

31) Incl. 10-metre power cable and guide bracket

32) z = number of blades

Amamix 400, 400 V, 50 Hz, n = 700 rpm, material variant C - version with jet ring

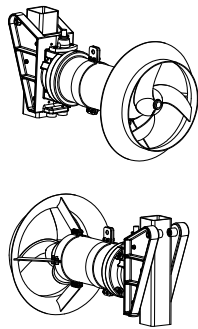
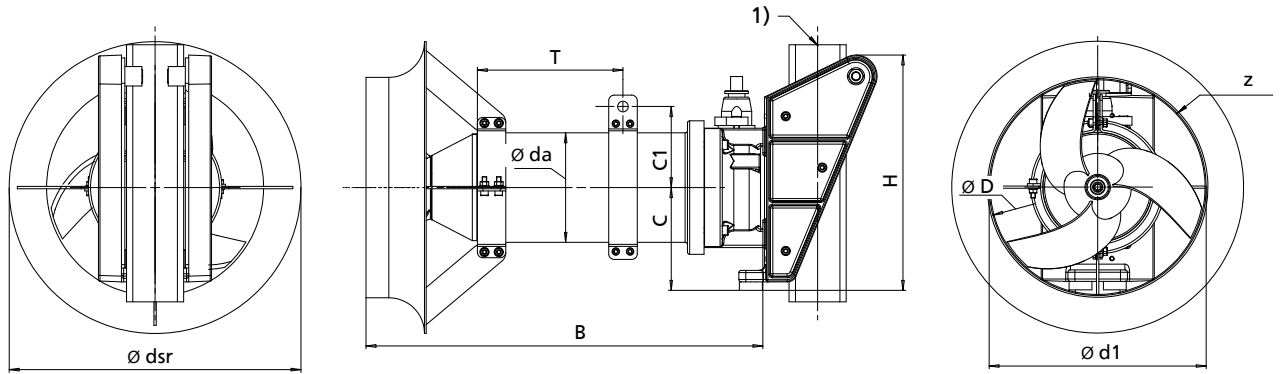

Minimum dimensions of access opening

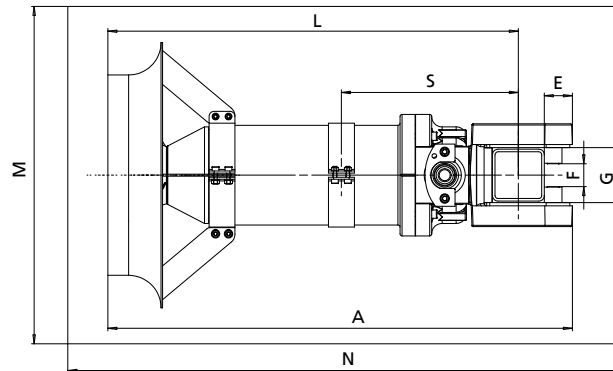

Guide rail

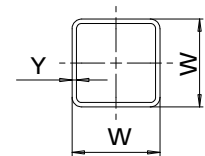

1) = guide rail

Technical data

Size	P ₂ [kW]	[kg] ³³⁾	z ³⁴⁾	Guide rail	
				W [mm]	Y [mm]
C 3725 R / 3 8 UDC / YDC	2,5	89,3	2	60	3
C 3728 R / 3 8 UDC / YDC	2,5	89,3	2	60	3
C 3731 R / 3 8 UDC / YDC	2,5	89,3	3	60	3
C 3738 R / 3 8 UDC / YDC	2,5	89,3	3	60	3
C 3725 R / 4 8 UDC / YDC	4	89,3	2	60	3
C 3728 R / 4 8 UDC / YDC	4	89,3	2	60	3
C 3738 R / 4 8 UDC / YDC	4	89,3	3	60	3
C 3731 R / 4 8 UDC / YDC	4	89,3	3	60	3
C 3735 R / 4 8 UDC / YDC	4	89,3	3	60	3

Dimensions [mm]

Size	A	B	C	C1	$\varnothing D$	$\varnothing da$	$\varnothing d1$	$\varnothing dsr$	E	F	G	H	L	M	N	S	T
C 3725 R / 3 8 UDC / YDC	855	695	150	139	373	186	380	511	42	36	66	287	783	610	1050	338	255
C 3728 R / 3 8 UDC / YDC	855	695	150	139	373	186	380	511	42	36	66	287	783	610	1050	338	255
C 3731 R / 3 8 UDC / YDC	855	695	150	139	373	186	380	511	42	36	66	287	783	610	1050	338	255
C 3738 R / 3 8 UDC / YDC	855	695	150	139	373	186	380	511	42	36	66	287	783	610	1050	338	255
C 3725 R / 4 8 UDC / YDC	855	695	150	139	373	186	380	511	42	36	66	287	783	610	1050	338	255
C 3728 R / 4 8 UDC / YDC	855	695	150	139	373	186	380	511	42	36	66	287	783	610	1050	338	255
C 3738 R / 4 8 UDC / YDC	855	695	150	139	373	186	380	511	42	36	66	287	783	610	1050	338	255
C 3731 R / 4 8 UDC / YDC	855	695	150	139	373	186	380	511	42	36	66	287	783	610	1050	338	255
C 3735 R / 4 8 UDC / YDC	855	695	150	139	373	186	380	511	42	36	66	287	783	610	1050	338	255

33) Incl. 10-metre power cable and guide bracket

34) z = number of blades

Amamix 600, 400 V, 50 Hz, n = 475 rpm, material variant G - version with jet ring

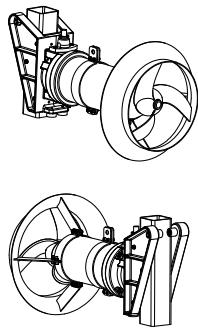
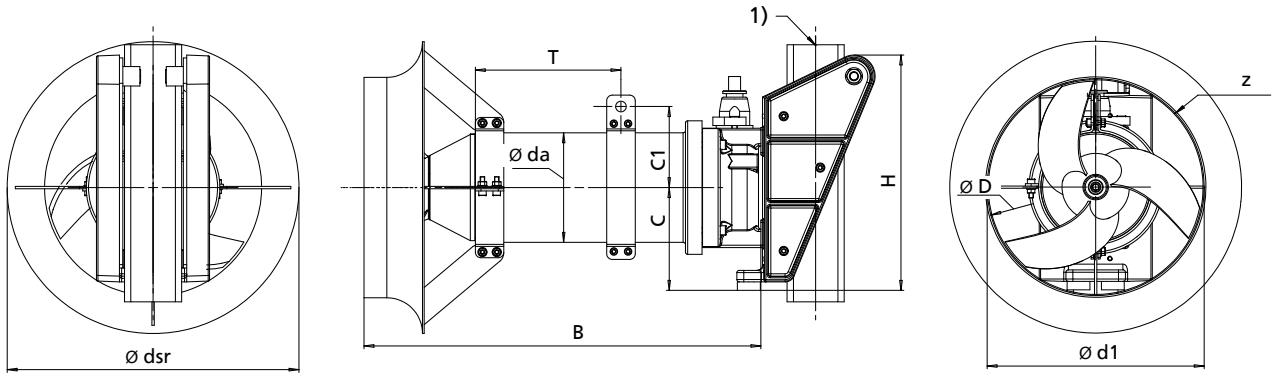

Minimum dimensions of access opening

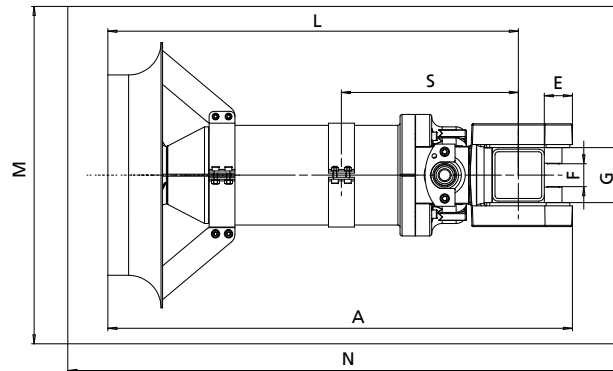

Guide rail

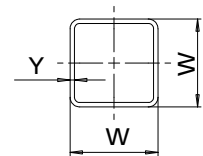

1) = guide rail

Technical data

Size	P ₂ [kW]	[kg] ³⁵⁾	z ³⁶⁾	Guide rail	
				W [mm]	Y [mm]
C 5725 R / 6 12 UDG / YDG	5	240,5	2	100	5
C 5728 R / 6 12 UDG / YDG	5	240,5	2	100	5
C 5731 R / 6 12 UDG / YDG	5	240,5	3	100	5
C 5738 R / 6 12 UDG / YDG	5	240,5	3	100	5
C 5725 R / 10 12 UDG / YDG	10	254,5	2	100	5
C 5728 R / 10 12 UDG / YDG	10	254,5	2	100	5
C 5738 R / 10 12 UDG / YDG	10	254,5	3	100	5
C 5731 R / 10 12 UDG / YDG	10	254,5	3	100	5
C 5735 R / 10 12 UDG / YDG	10	254,5	3	100	5

Dimensions [mm]

Size	A	B	C	C1	∅ D	∅ da	∅ d1	∅ dsr	E	F	G	H	L	M	N	S	T
C 5725 R / 6 12 UDG / YDG	1048	854	230	197	570	294	580	773	54	44	106	507	953	875	1335	403	270
C 5728 R / 6 12 UDG / YDG	1048	854	230	197	570	294	580	773	54	44	106	507	953	875	1335	403	270
C 5731 R / 6 12 UDG / YDG	1048	854	230	197	570	294	580	773	54	44	106	507	953	875	1335	403	270
C 5738 R / 6 12 UDG / YDG	1048	854	230	197	570	294	580	773	54	44	106	507	953	875	1335	403	270
C 5725 R / 10 12 UDG / YDG	1048	854	230	197	570	294	580	773	54	44	106	507	953	875	1335	403	270
C 5728 R / 10 12 UDG / YDG	1048	854	230	197	570	294	580	773	54	44	106	507	953	875	1335	403	270
C 5738 R / 10 12 UDG / YDG	1048	854	230	197	570	294	580	773	54	44	106	507	953	875	1335	403	270
C 5731 R / 10 12 UDG / YDG	1048	854	230	197	570	294	580	773	54	44	106	507	953	875	1335	403	270
C 5735 R / 10 12 UDG / YDG	1048	854	230	197	570	294	580	773	54	44	106	507	953	875	1335	403	270

35) Incl. 10-metre power cable and guide bracket

36) z = number of blades

Amamix 600, 400 V, 50 Hz, n = 475 rpm, material variant C - version with jet ring

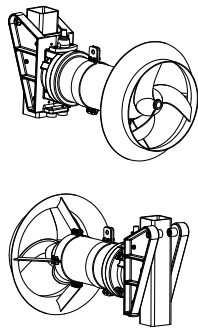
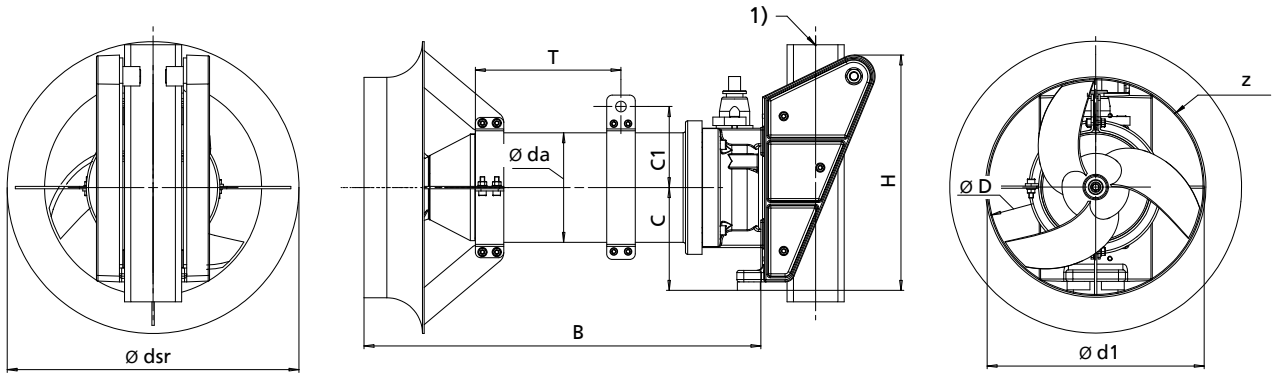

Minimum dimensions of access opening

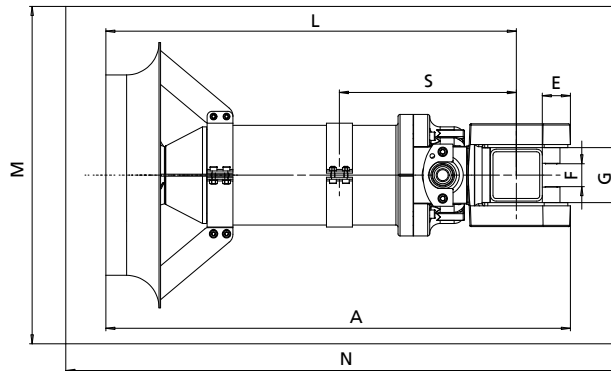

Guide rail

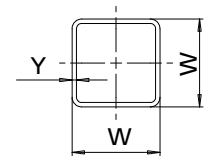

1) = guide rail

Technical data

Size	P ₂ [kW]	[kg] ³⁷⁾	z ³⁸⁾	Guide rail	
				W [mm]	Y [mm]
C 5725 R / 4 12 UMC / YMC	5	165,5	2	100	5
C 5728 R / 4 12 UMC / YMC	5	165,5	2	100	5
C 5731 R / 4 12 UMC / YMC	5	165,5	3	100	5
C 5738 R / 4 12 UMC / YMC	5	165,5	3	100	5
C 5725 R / 8 12 UMC / YMC	10	217,5	2	100	5
C 5728 R / 8 12 UMC / YMC	10	217,5	2	100	5
C 5738 R / 8 12 UMC / YMC	10	217,5	3	100	5
C 5731 R / 8 12 UMC / YMC	10	217,5	3	100	5
C 5735 R / 8 12 UMC / YMC	10	217,5	3	100	5

Dimensions [mm]

Size	A	B	C	C1	∅ D	∅ da	∅ d1	∅ dsr	E	F	G	H	L	M	N	S	T
C 5725 R / 4 12 UMC / YMC	1016	830	215	176	570	251	580	773	43	44	106	420	908	890	1290	380	250
C 5728 R / 4 12 UMC / YMC	1016	830	215	176	570	251	580	773	43	44	106	420	908	890	1290	380	250
C 5731 R / 4 12 UMC / YMC	1016	830	215	176	570	251	580	773	43	44	106	420	908	890	1290	380	250
C 5738 R / 4 12 UMC / YMC	1016	830	215	176	570	251	580	773	43	44	106	420	908	890	1290	380	250
C 5725 R / 8 12 UMC / YMC	1137	950	215	176	570	251	580	773	43	44	106	420	1028	890	1410	445	310
C 5728 R / 8 12 UMC / YMC	1137	950	215	176	570	251	580	773	43	44	106	420	1028	890	1410	445	310
C 5738 R / 8 12 UMC / YMC	1137	950	215	176	570	251	580	773	43	44	106	420	1028	890	1410	445	310
C 5731 R / 8 12 UMC / YMC	1137	950	215	176	570	251	580	773	43	44	106	420	1028	890	1410	445	310
C 5735 R / 8 12 UMC / YMC	1137	950	215	176	570	251	580	773	43	44	106	420	1028	890	1410	445	310

37) Incl. 10-metre power cable and guide bracket

38) z = number of blades

Scope of supply

Depending on the model, the following items are included in the scope of supply:

- Submersible mixer with supporting clamp
- Cable support for properly routing the power cable
- Two shackles (for lifting tackle and cable support)
- Separate name plate

Accessories

- Submersible mixer stand
- Pitch adapter
- Bail
- Hook
- Lifting rope
- Cable support for properly routing the power cables
- Forcing screw
- Other accessories on request

Accessories

Overview of accessories

Overview of accessories

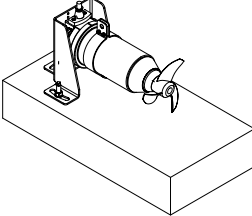
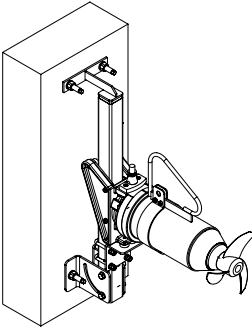
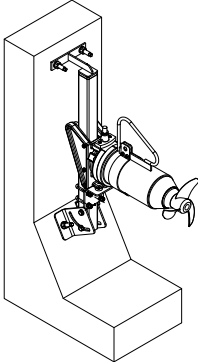
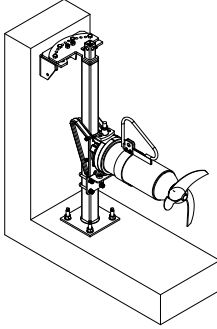
Accessories	Amamix				Illustration	Description
	200	300	400	600		
Accessories set 4 (⇒ Page 33)	X	X	X	X		<ul style="list-style-type: none"> Lifting devices and lifting tackle
Accessories set 6 Floor mounting (⇒ Page 35)	X	X	-	-		<ul style="list-style-type: none"> With horizontal swivelling option Fixed vertical installation height Condition: Place of installation is accessible (e.g. stormwater relief structures)
Accessories set 7 Mounting on sump/tank wall (⇒ Page 37)	X	X	-	-		<ul style="list-style-type: none"> Continuously adjustable installation depth with fixed jet direction. The submersible mixer can be lifted out of the tank or sump for maintenance and inspection work.
Accessories set 7 Mounting on benching and sump/tank wall (⇒ Page 37)	X	X	-	-		<ul style="list-style-type: none"> Special feature: continuously adjustable installation depth and adjustable jet direction. The submersible mixer can be lifted out of the tank or sump for maintenance and inspection work.
Accessories set 22 Mounting on the sump/tank wall and horizontal tank floor (inclined by 0 - 0.5°) (⇒ Page 42)	X	X	X	X		<ul style="list-style-type: none"> Special feature: continuously adjustable installation depth and adjustable jet direction. The submersible mixer can be lifted out of the tank or sump for maintenance and inspection work.

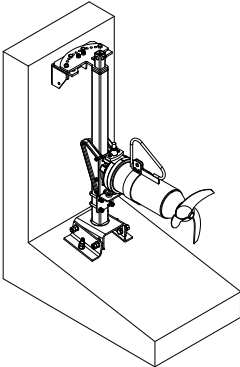
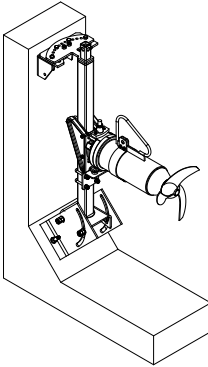
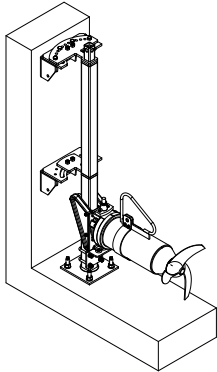
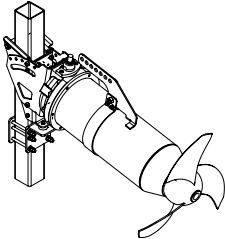
Accessories	Amamix				Illustration	Description
	200	300	400	600		
Accessories set 22 Mounting on the sump/tank floor and sloping tank floor (inclined by 0.5 - 10°) (⇒ Page 45)	X	X	X	X		<ul style="list-style-type: none"> Special feature: continuously adjustable installation depth and adjustable jet direction. The submersible mixer can be lifted out of the tank or sump for maintenance and inspection work.
Accessories set 22 Mounting on the sump/tank wall and on the inclined tank floor or on the sump/tank wall (inclined by 10 - 90°) (⇒ Page 49)	X	X	X	X		<ul style="list-style-type: none"> Special feature: continuously adjustable installation depth and adjustable jet direction. The submersible mixer can be lifted out of the tank or sump for maintenance and inspection work.
Accessories set 22 Accessories set 22 - options with middle support for guide rail (⇒ Page 53)	X	X	X	X		<ul style="list-style-type: none"> For installation depths > 6 m
Accessories set 22 Accessories set 22 - options Pitch adapter (⇒ Page 56)	X	X	X	X		<ul style="list-style-type: none"> For upward or downward pitch adjustment in increments of 10° from 40° upwards to 40° downwards (Amamix 600 G: 15° or 30° upward or downward pitch)
Forcing screws (⇒ Page 63)	X	X	X	X		
Guide rails for accessories sets 7 and 22 (⇒ Page 64)	X	X	X	X		
Wear-resistant adapter (⇒ Page 64)	-	X	X	X		
Other accessories (⇒ Page 65)	X	X	X	X		
Lifting equipment	X	X	X	X		<ul style="list-style-type: none"> See type series booklet "KSB Lifting Equipment" 1596.5

Accessories set 4

Overview of range
Lifting tackle

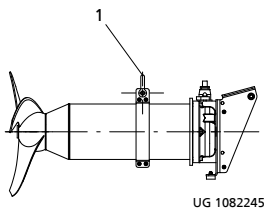

Lifting tackle

1	Attachment point (centre-of-gravity position) ³⁹⁾
---	--

Lifting ropes

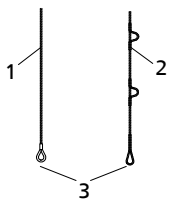

Lifting rope

1	Lifting rope made of 1.4401 or
2	Lifting rope made of PP
3	Attachment point on submersible mixer

Rope winder/bollard

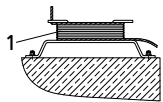

1	Rope winder
---	-------------

Alternative combination: bail on submersible mixer / lifting hook on lifting rope of lifting equipment

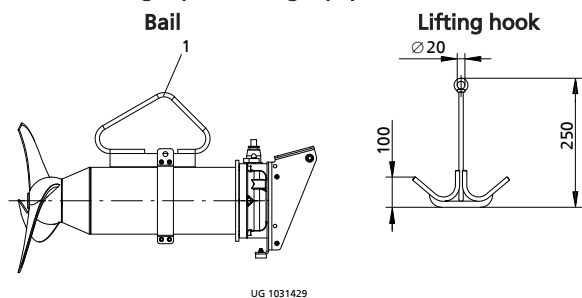

1 Bail

Overview of accessories set 4: lifting devices and lifting tackle

Description	Amamix								Material	Mat. No.	[kg]
	200		300		400		600				
	G	C	G	C	G	C	G	C			
Lifting rope for Haacon cranes ⁴⁰⁾	∅ = 5 mm, L = 12 m								1.4401	11304621	1.95
	∅ = 5 mm, L = 18 m								1.4401	11306713	2.7

³⁹⁾ Shackle included in scope of supply

Description	Amamix								Material	Mat. No.	[kg]
	200		300		400		600				
	G	C	G	C	G	C	G	C			
∅ = 5 mm, L = 22 m	X	X	X	X	X	X	X	X	1.4401	11306712	3.2
Lifting rope, max. load-carrying capacity 200 kg, 5 m; material: polypropylene ⁴¹⁾	Select in acc. with mixer weight								PP	11185207	2
Lifting rope, max. load-carrying capacity 450 kg, 5 m; material: polypropylene ⁴¹⁾									PP	11190024	5
Rope winder/bollard for Haacon cranes for securing the lifting ropes at the tank edge or railing									1.4571	19554260	1.5
Lifting hook, max. load-carrying capacity 500 kg	X	X	X	X	X	X	X	X	1.4301	19219613	2.44
Bail for fitting to the lifting lug	X	X	-	-	-	-	-	-	1.4571	19219830	1.6
	-	-	X	X	X	X	-	-	1.4571	19219831	2.1
	-	-	-	-	-	-	X	X	1.4571	19219832	2.6

More information

- See type series booklet "KSB Lifting Equipment" 1596.5

⁴⁰⁾ The lifting rope must be attached to the attachment point on the submersible mixer and can be fastened on the winch of the cranes indicated. When transportable cranes are used, the upper end of the rope is removed from the winch and tied securely around the rope winder. The lower end remains attached to the submersible mixer.

⁴¹⁾ Use several 5-metre ropes connected via spliced loops for large installation depths.

Accessories set 6

Overview of range

For permanent mounting of the submersible mixer on the tank floor.

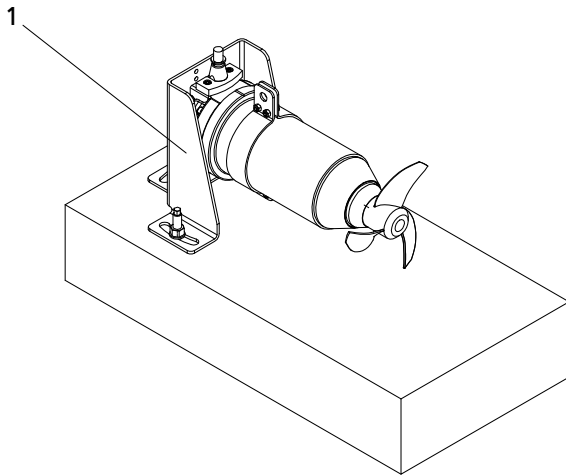

Installation using accessories set 6: permanent mounting of submersible mixer on tank floor

1	Submersible mixer stand
---	-------------------------

Overview of accessories set 6

Description	Amamix				Material	Mat. No.	[kg]
	200	300	400	600			
Submersible mixer stand (for use in tanks which can be drained to provide access to the submersible mixer, e.g. for maintenance and inspection purposes, e.g. stormwater relief structures) incl. 3 chemical anchors for mounting the submersible mixer stand on the tank floor, min. concrete quality C25/30	X	X	42)	42)	1.4301	01109062	8
					1.4571	19556921	8

42) On request

Installation of accessories set 6 - Amamix 200 / 300

For permanent mounting on the tank floor
(sizes 400 and 600 on request)

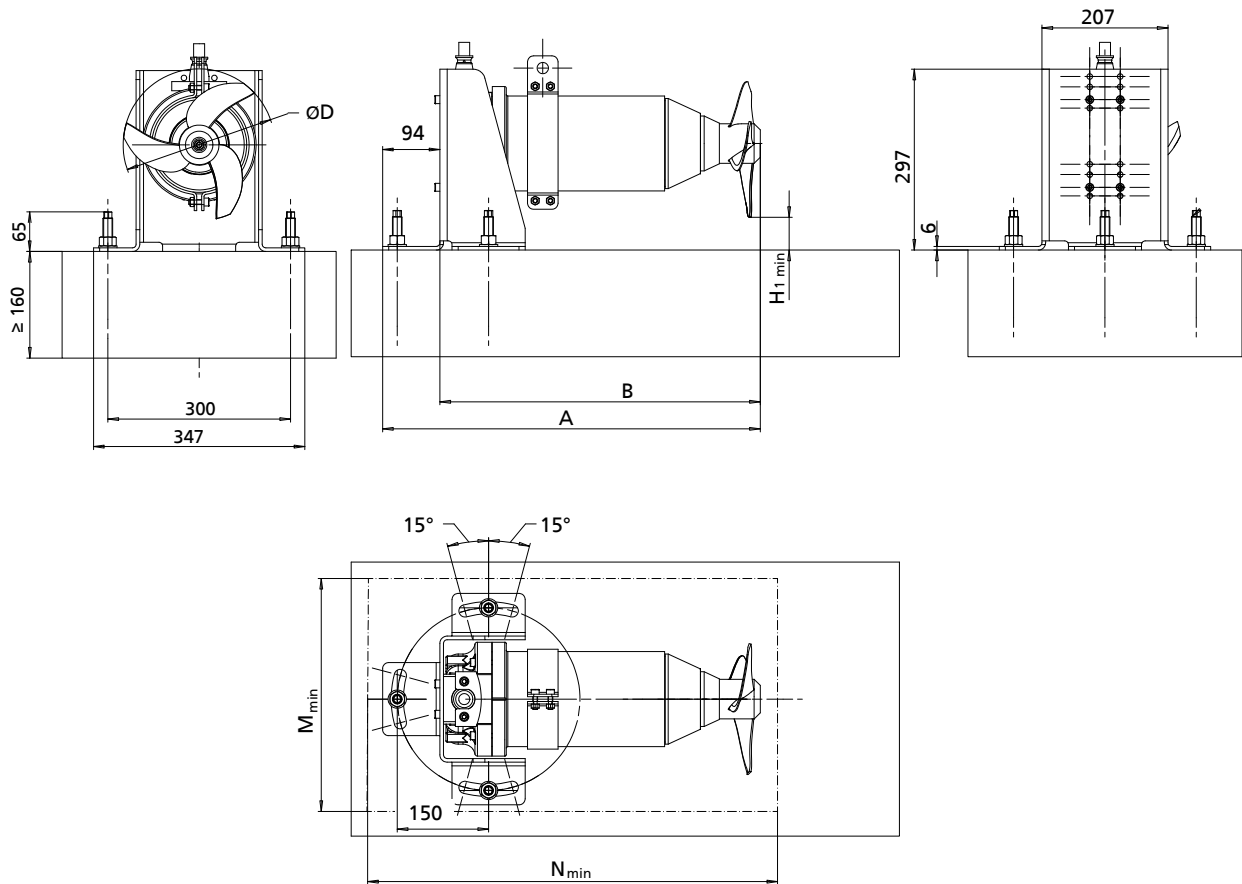

Installation with accessories set 6 - Amamix 200 / 300

Dimensions [mm]

$\varnothing D$	$H_{1\ min}$	A	B	M_{\min}	N_{\min}
200	48,5	560	466	400	610
300	50	694	600	400	750

Accessories set 7

Overview of range

For mounting at the top of the tank wall and at the bottom of the tank wall/benching, level-adjustable.

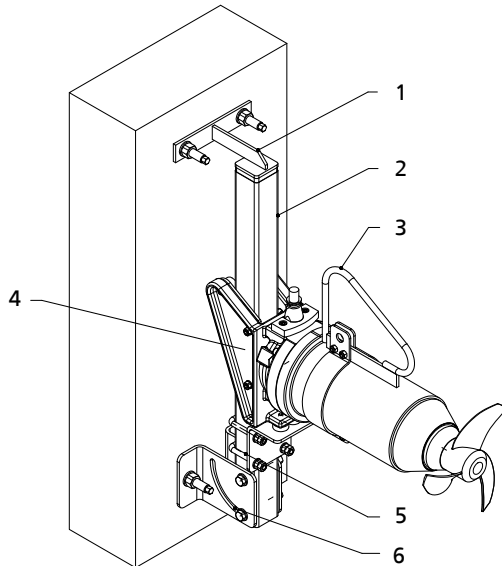

Installation example: mounted on the tank wall

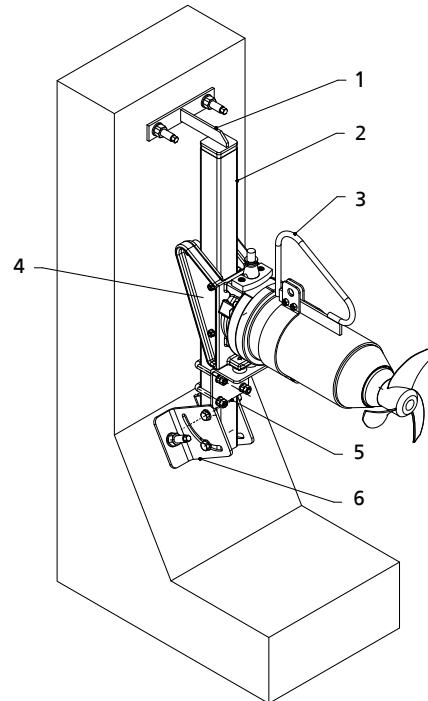

Installation example: mounted on the benching

1	Upper holder	4	Guide bracket for guide rail
2	Guide rail ⁴³⁾	5	Retaining bracket for guide rail
3	Bail (optional)	6	Lower holder

Overview of accessories set 7: mounting at the tank wall or on the benching

Description	Amamix				Material	Mat. No.	[kg]
	200		300				
	G	C	G	C			
Upper holder for guide rail 60 x 60 x 3 mm	X	X	X	X	1.4301	01109095	1.5
Upper holder for guide rail 60 x 60 x 3 mm	X	X	X	X	1.4571	01103807	1.5
Guide rail	(â Page 64)						
Guide bracket for guide rail 60 x 60 x 3 mm ⁴⁴⁾	X	-	X	-	EN-GJL-250	19203139	6.83
Guide bracket for guide rail 60 x 60 x 3 mm	-	X	-	X	1.4571	19202241	3.4
Retaining bracket for guide rail 60 x 60 x 3 mm ⁴⁵⁾	X	X	X	X	1.4571	19202369	1.5
Retaining bracket for guide rail 60 x 60 x 3 mm ⁴⁵⁾	X	X	X	X	1.4301	01109104	1.5
Lower holder for guide rail 60 x 60 x 3 mm	X	X	X	X	1.4301	01109097	2.8
Lower holder for guide rail 60 x 60 x 3 mm	X	X	X	X	1.4571	01103809	2.8

⁴³⁾ Not included in KSB's general scope of supply

⁴⁴⁾ Optional: guide bracket for guide rail 60 x 60 x 3 mm made of 1.4571 (19202241)

⁴⁵⁾ The materials of the retaining bracket and of the guide rail are usually identical.

Installation of accessories set 7 - Amamix 200 / 300

For mounting at the top of the tank wall and on the benching, level-adjustable.

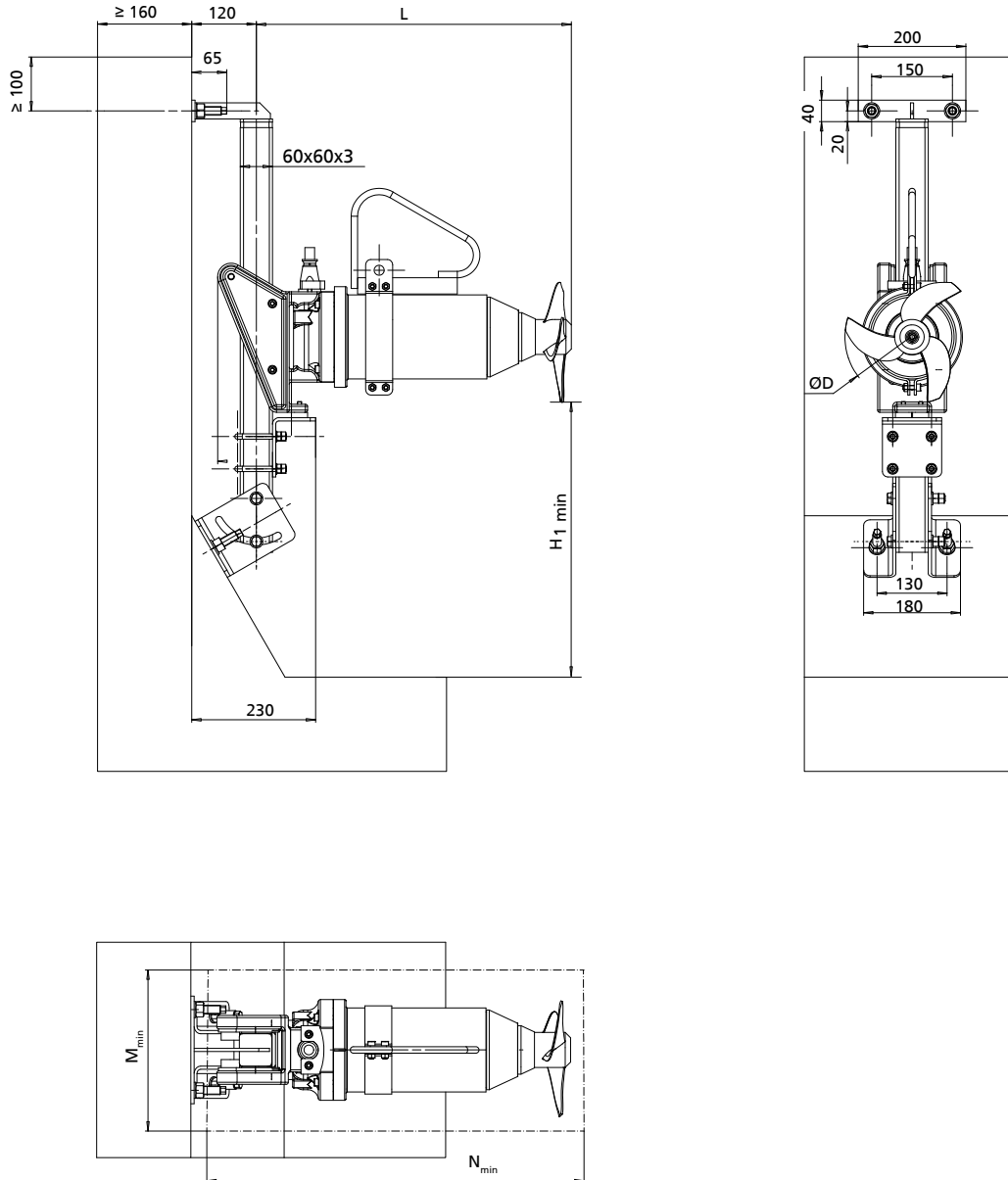

Installation with accessories set 7 - Amamix 200 / 300

Dimensions [mm]

Ø D	Motor housing material	H ₁	L	M _{min}	N _{min}
200	G	120	524	275	700
200	C	120	520	275	700
300	G	150	659	375	830
300	C	150	655	375	830

Installation of accessories set 7 - Amamix 200 / 300

For mounting at the top and bottom of the tank wall,
level-adjustable.

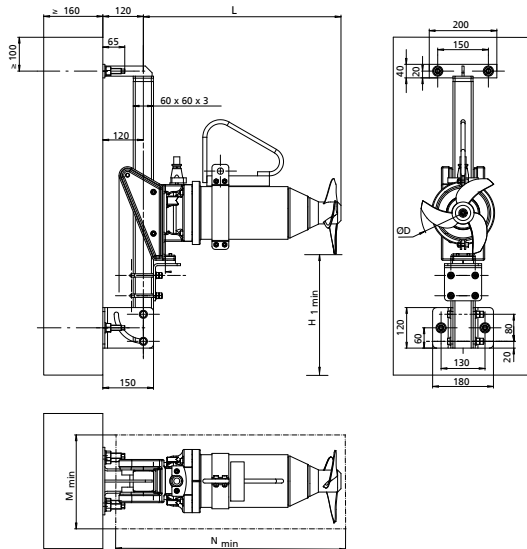

Installation of accessories set 7 - Amamix 200 / 300

Dimensions [mm]

Ø D	Motor housing material	H ₁	L	M _{min}	N _{min}
200	G	120	524	275	700
200	C	120	520	275	700
300	G	150	659	375	830
300	C	150	655	375	830

Accessories set 22

Accessories set 22 comprises the upper guide rail holder, the guide rail, the retaining bracket and the lower guide rail holder.

Guide rails

The cross-section of the guide rail depends on the mixer size:

Overview of guide rails

Amamix	Guide rail cross-section	
	60 × 60 × 3 mm	100 × 100 × 5 mm
200	X	-
300	X	-
400	X	X
600	-	X

The guide rail can be supplied either by KSB or the customer/operator.

Overview of guide rails

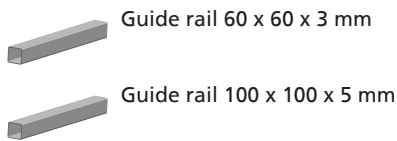

Upper holder

The upper holder is identical for all installation variants (installation on horizontal, sloping or inclined floor). Two designs are available:

Overview of upper holders

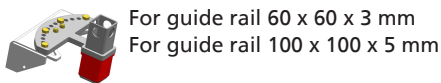

Lower holder

Different types of lower holders are available to match individual tank floor designs.

Overview of lower holders

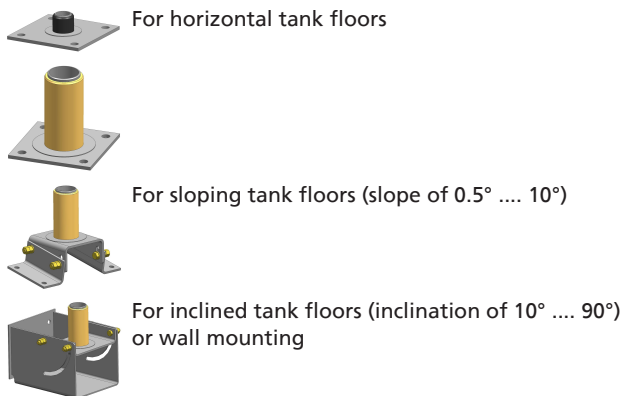

Retaining bracket

The retaining bracket is mounted on the guide rail and serves as a bottom stop for the submersible mixer. Retaining brackets are available for guide rails 60 x 60 x 3 mm and 100 x 100 x 5 mm.

Overview of retaining brackets

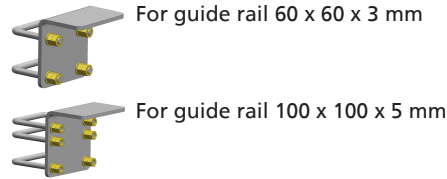

Guide bracket for guide rail

The guide bracket is bolted to the motor housing cover of the submersible mixer and serves to guide the submersible mixer along the guide rail. Any forces generated by the submersible mixer, such as the reactive force to the propeller's axial thrust, the motor torque and any lateral forces are transferred into the guide rail via the guide bracket and thus safely dissipated into the foundation (tank wall and floor). The upper holder provides a mixer swivelling option around the guide rail axis of up to 45° towards both sides.

Overview of guide brackets for the guide rail



Pitch adapter

The pitch adapter is fitted between the motor housing cover of the submersible mixer and the guide bracket. By fitting a pitch adapter, the jet pitch can be adjusted either upwards or downwards from the standard horizontal installation position.

Overview of pitch adapters



For all sizes except Amamix 600 G⁴⁶⁾



15°-pitch adapter for Amamix 600 G⁴⁷⁾

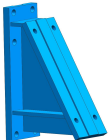

30°-pitch adapter for Amamix 600 G⁴⁸⁾

Middle support

For installation depths > 6 m a middle support is required for the guide rail; this may also be useful for lower installation depths depending on tank design and flow conditions.

Overview of middle supports

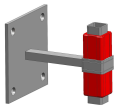

For guide rail 60 x 60 x 3 mm

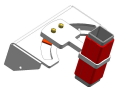

For guide rail 100 x 100 x 5 mm

⁴⁶⁾ Pitch can be adjusted through a range of +/- 40°, depending on the mixer size.

⁴⁷⁾ Allows only fixed angles of 15°, jet direction (upward or downward) must be specified in the purchase order.

⁴⁸⁾ Allows only fixed angles of 30°, jet direction (upward or downward) must be specified in the purchase order.

For mounting on the tank wall and horizontal tank floor

Overview of range

Installation using accessories set 22: mounting on the tank wall and horizontal tank floor

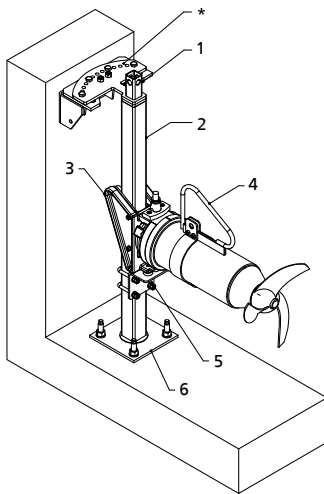

Amamix 200, 300, 400

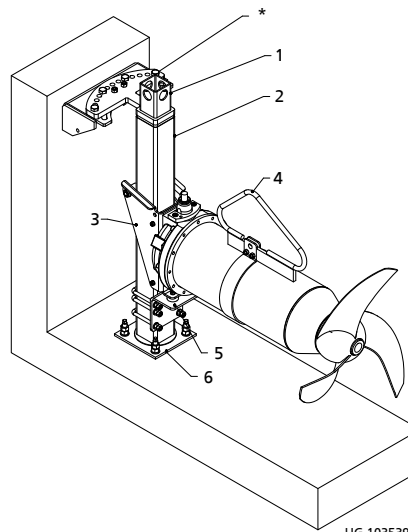

Amamix 400, 600

*	Swivelling option through 45° to the left and right around the guide rail axis (in increments of 7.5°)	4	Bail (optional)
1	Upper holder	5	Retaining bracket for guide rail
2	Guide rail ⁴⁹⁾	6	Lower holder
3	Guide bracket for guide rail		

Overview of standard accessories set 22: mounting on the tank wall and horizontal tank floor

Description	Amamix				Material	Mat. No.	[kg]		
	200		300						
	G	C	G	C					
Upper holder for guide rail 60 x 60 x 3 mm, incl. 2 chemical anchors	X	X	X	X	-	-	1.4301	01306260	8.9
Upper holder for guide rail 60 x 60 x 3 mm, incl. 2 chemical anchors	X	X	X	X	X	-	1.4571	01306261	8.9
Upper holder for guide rail 100 x 100 x 5 mm, incl. 2 chemical anchors	-	-	-	X	X	X	1.4301	01313458	23.23
Upper holder for guide rail 100 x 100 x 5 mm, incl. 2 chemical anchors	-	-	-	X	X	X	1.4571	01313459	23.23
Guide rail	(⇒ Page 64)								
Guide bracket for guide rail 60 x 60 x 3 mm ⁵⁰⁾	X	-	X	-	-	-	EN-GJL-250	19203139	6.83
Guide bracket for guide rail 60 x 60 x 3 mm ⁵¹⁾	-	-	-	X	-	-	EN-GJL-250	01307155	10.5
Guide bracket for guide rail 60 x 60 x 3 mm	-	X	-	X	-	-	1.4571	19202241	3.4
Guide bracket for guide rail 60 x 60 x 3 mm	-	-	-	-	X	-	1.4571	01307156	7
Guide bracket for guide rail 100 x 100 x 5 mm	-	-	-	-	-	X	EN-GJL-250	19556700	17
Guide bracket for guide rail 100 x 100 x 5 mm ⁵²⁾	-	-	-	X	-	-	EN-GJL-250	19556701	13
Guide bracket for guide rail 100 x 100 x 5 mm	-	-	-	-	X	-	1.4571	19202242	8.79
Retaining bracket for guide rail 60 x 60 x 3 mm	X	X	X	X	X	-	1.4301	01109104	1.5
Retaining bracket for guide rail 60 x 60 x 3 mm	X	X	X	X	X	-	1.4571	19202369	1.5
Retaining bracket for guide rail 100 x 100 x 5 mm	-	-	-	X	X	X	1.4301	01129810	3.5
Retaining bracket for guide rail 100 x 100 x 5 mm	-	-	-	X	X	X	1.4571	19202370	3.5
Lower holder for guide rail 60 x 60 x 3 mm, incl. 4 chemical anchors	X	X	X	X	X	-	1.4301	01129858	4.24
Lower holder for guide rail 60 x 60 x 3 mm, incl. 4 chemical anchors	X	X	X	X	X	-	1.4571	01129859	4.24
Lower holder for guide rail 100 x 100 x 5 mm, incl. 4 chemical anchors	-	-	-	X	X	X	1.4301	01118892	5.68
Lower holder for guide rail 100 x 100 x 5 mm, incl. 4 chemical anchors	-	-	-	X	X	X	1.4571	01118903	5.68

49) Not included in KSB's general scope of supply
 50) Optional: guide bracket for guide rail 60 x 60 x 3 mm made of 1.4571 (19202241)
 51) Optional: guide bracket for guide rail 60 x 60 x 3 mm made of 1.4571 (01307156)
 52) Optional: guide bracket for guide rail 100 x 100 x 5 mm made of 1.4571 (19202242)

Installation of accessories set 22 - Amamix 200 / 300 / 400 (except size 4135)

For mounting at the top of the tank wall and on the tank floor, level-adjustable and with horizontal swivelling option.

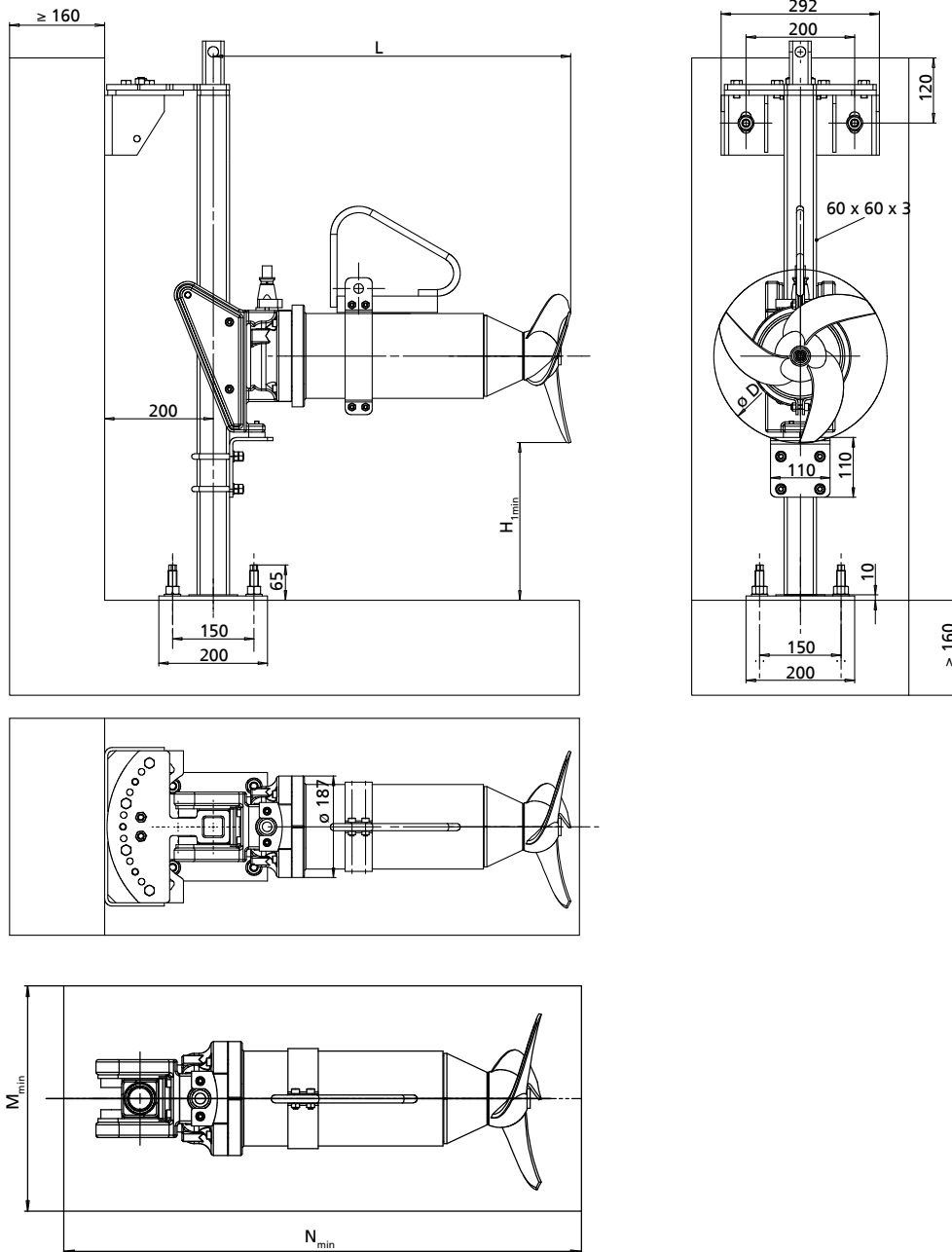

UG 1312313

Installation with accessories set 22 - Amamix 200 / 300 / 400 (except size 4135)

Dimensions [mm]

$\varnothing D$	Motor housing material	$H_{1\min}$	L	M_{\min}	N_{\min}
200	G	120	524	275	780
200	C	120	520	275	780
300	G	150	659	375	910
300	C	150	655	375	910
400	G	200	844	460	1050
400	C	200	844	460	1050

Installation of accessories set 22 - Amamix 400 (size 4135 only) / 600

For mounting at the top of the tank wall and on a horizontal tank floor, level-adjustable and with horizontal swivelling option.

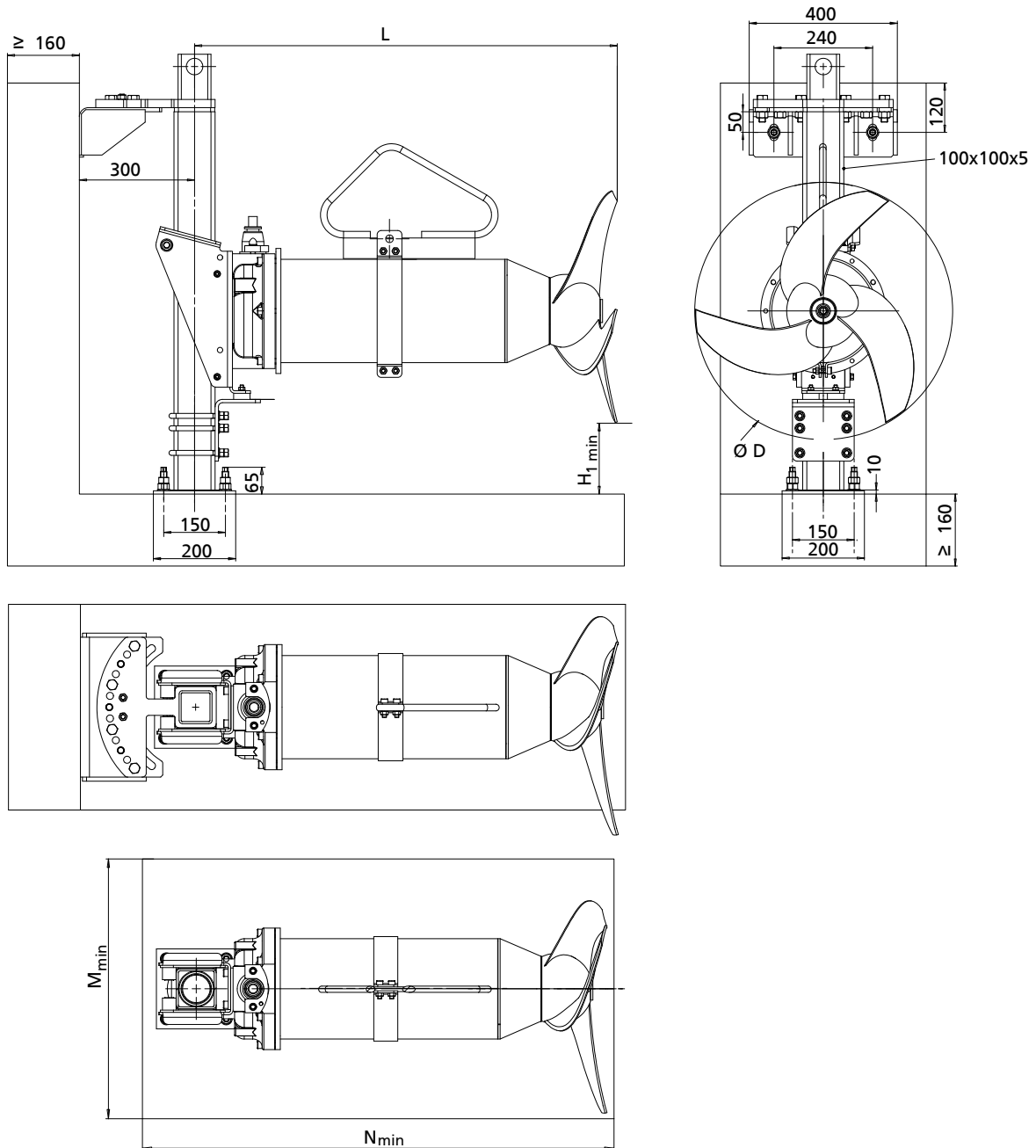

Installation with accessories set 22 - Amamix 400 (size 4135 only) / 600

Dimensions [mm]

Ø D	Motor housing material	H _{1 min}	L _{max}	M _{min}	N _{min}
400	G	205	783	460	1150
400	C	205	780	460	1150
600	G	315	949	700	1310
600	C	315	949	700	1390

For mounting on the tank wall and on a sloping tank floor (0.5° - 10°)

Overview of range

Installation using accessories set 22: mounting on the tank wall and on a sloping tank floor (0.5° ... 10°)

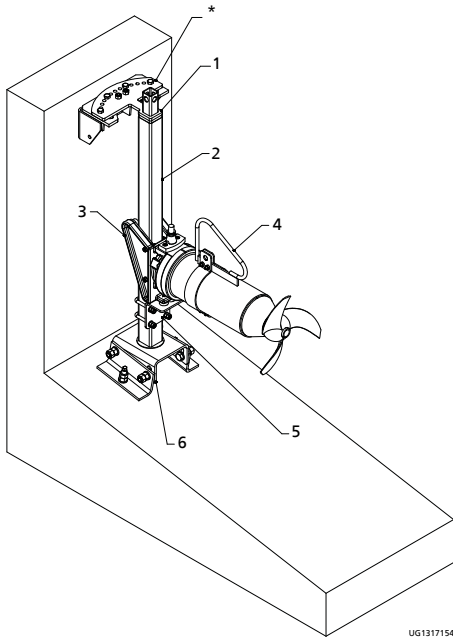

Amamix 200, 300, 400

UG1317154

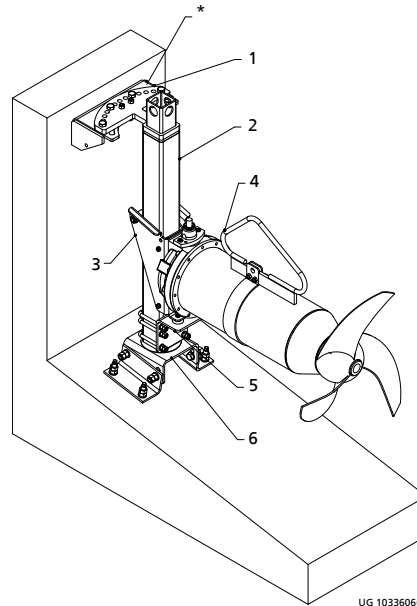

Amamix 400, 600

UG 10336066

*	Swivelling option through 45° to the left and right around the guide rail axis (in increments of 7.5°)	4	Bail (optional)
1	Upper holder	5	Retaining bracket for guide rail
2	Guide rail ⁵³⁾	6	Lower holder
3	Guide bracket for guide rail		

Overview of standard accessories set 22: mounting on the tank wall and on a sloping tank floor (0.5° ... 10°)

Description	Amamix								Material	Mat. No.	[kg]
	200		300		400		600				
	G	C	G	C	G	C	G	C			
Upper holder for guide rail 60 x 60 x 3 mm, incl. 2 chemical anchors	X	X	X	X	X	X	-	-	1.4301	01306260	8.9
Upper holder for guide rail 60 x 60 x 3 mm, incl. 2 chemical anchors	X	X	X	X	X	X	-	-	1.4571	01306261	8.9
Upper holder for guide rail 100 x 100 x 5 mm, incl. 2 chemical anchors	-	-	-	-	X	X	X	X	1.4301	01313458	23.23
Upper holder for guide rail 100 x 100 x 5 mm, incl. 2 chemical anchors	-	-	-	-	X	X	X	X	1.4571	01313459	23.23
Guide rail	(⇒ Page 64)										
Guide bracket for guide rail 60 x 60 x 3 mm ⁵⁴⁾	X	-	X	-	-	-	-	-	EN-GJL-250	19203139	6.83
Guide bracket for guide rail 60 x 60 x 3 mm ⁵⁵⁾	-	-	-	-	X	-	-	-	EN-GJL-250	01307155	10.5
Guide bracket for guide rail 60 x 60 x 3 mm	-	X	-	X	-	-	-	-	1.4571	19202241	3.4
Guide bracket for guide rail 60 x 60 x 3 mm	-	-	-	-	-	X	-	-	1.4571	01307156	7
Guide bracket for guide rail 100 x 100 x 5 mm ⁵⁶⁾	-	-	-	-	-	-	X	-	EN-GJL-250	19556700	17
Guide bracket for guide rail 100 x 100 x 5 mm	-	-	-	-	X	-	-	-	EN-GJL-250	19556701	13
Guide bracket for guide rail 100 x 100 x 5 mm	-	-	-	-	-	X	-	-	1.4571	19202242	8.79
Retaining bracket for guide rail 60 x 60 x 3 mm	X	X	X	X	X	X	-	-	1.4301	01109104	1.5
Retaining bracket for guide rail 60 x 60 x 3 mm	X	X	X	X	X	X	-	-	1.4571	19202369	1.5
Retaining bracket for guide rail 100 x 100 x 5 mm	-	-	-	-	X	X	X	X	1.4301	01129810	3.5
Retaining bracket for guide rail 100 x 100 x 5 mm	-	-	-	-	X	X	X	X	1.4571	19202370	3.5

⁵³⁾ Not included in KSB's general scope of supply

⁵⁴⁾ Optional: guide bracket for guide rail 60 x 60 x 3 mm made of 1.4571 (19202241)

⁵⁵⁾ Optional: guide bracket for guide rail 60 x 60 x 3 mm made of 1.4571 (01307156)

⁵⁶⁾ Optional: guide bracket for guide rail 100 x 100 x 5 mm made of 1.4571 (19202242)

Description	Amamix								Material	Mat. No.	[kg]
	200		300		400		600				
	G	C	G	C	G	C	G	C			
Lower holder for guide rail 60 x 60 x 3 mm, incl. 4 chemical anchors	X	X	X	X	X	X	-	-	1.4301	01129860	9.4
Lower holder for guide rail 60 x 60 x 3 mm, incl. 4 chemical anchors	X	X	X	X	X	X	-	-	1.4571	01129861	9.4
Lower holder for guide rail 100 x 100 x 5 mm, incl. 4 chemical anchors	-	-	-	-	X	X	X	X	1.4301	01118906	11.92
Lower holder for guide rail 100 x 100 x 5 mm, incl. 4 chemical anchors	-	-	-	-	X	X	X	X	1.4571	01118907	11.92

Installation with accessories set 22 - Amamix 200 / 300 / 400

For mounting at the top of the tank wall and on a sloping tank floor (0.5° - 10°), level-adjustable and with horizontal swivelling option.

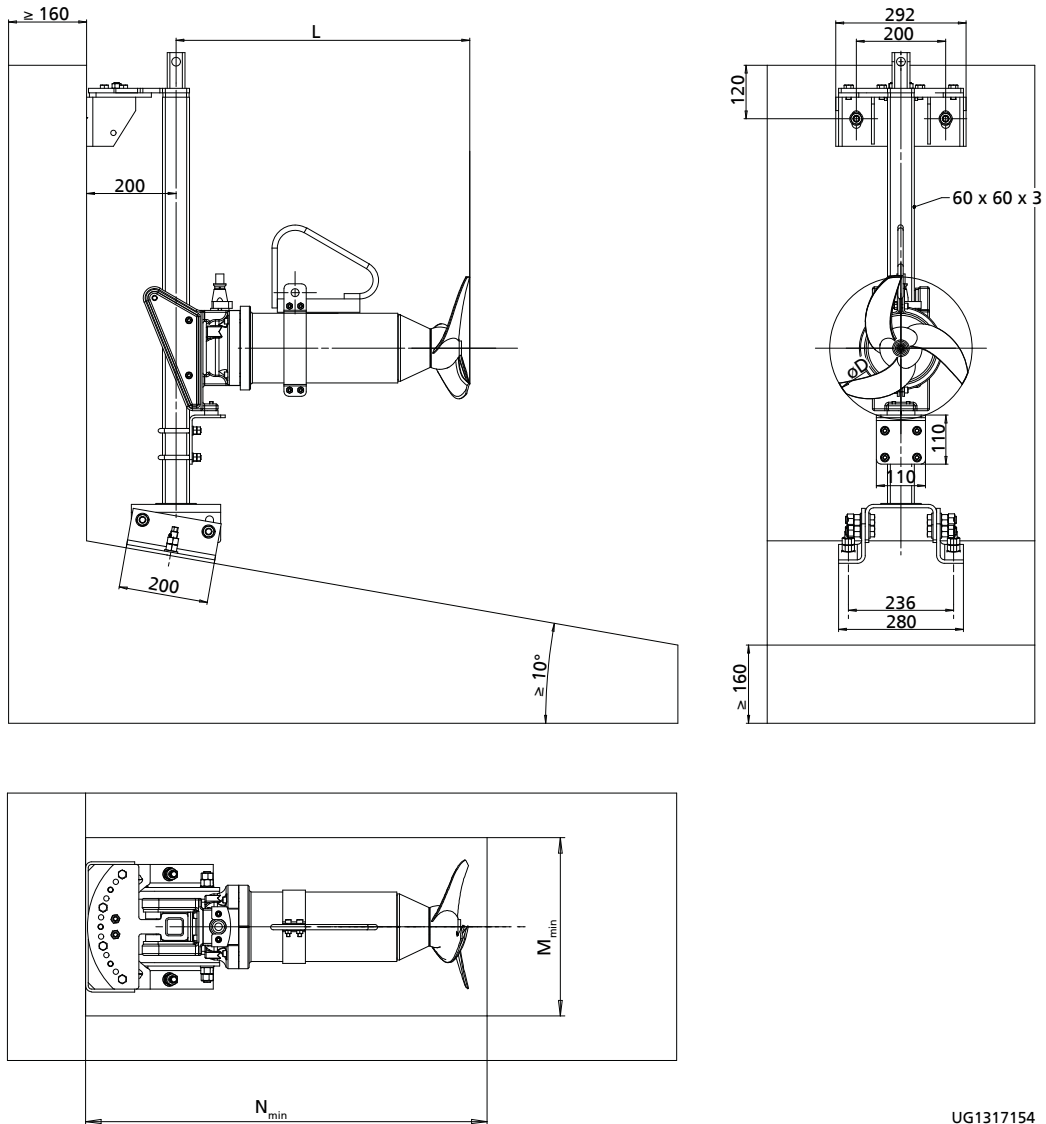

UG1317154

Installation with accessories set 22 - Amamix 200, 300, 400

Dimensions [mm]

Ø D	Motor housing material	L	M _{min}	N _{min}
200	G	524	275	780
200	C	520	275	780
300	G	659	375	910
300	C	655	375	910
400	G	844	460	1050
400	C	844	460	1050

Installation of accessories set 22 - Amamix 400 (size 4135 only) / 600

For mounting at the top of the tank wall and on a sloping tank floor (0.5° - 10°), level-adjustable and with horizontal swivelling option.

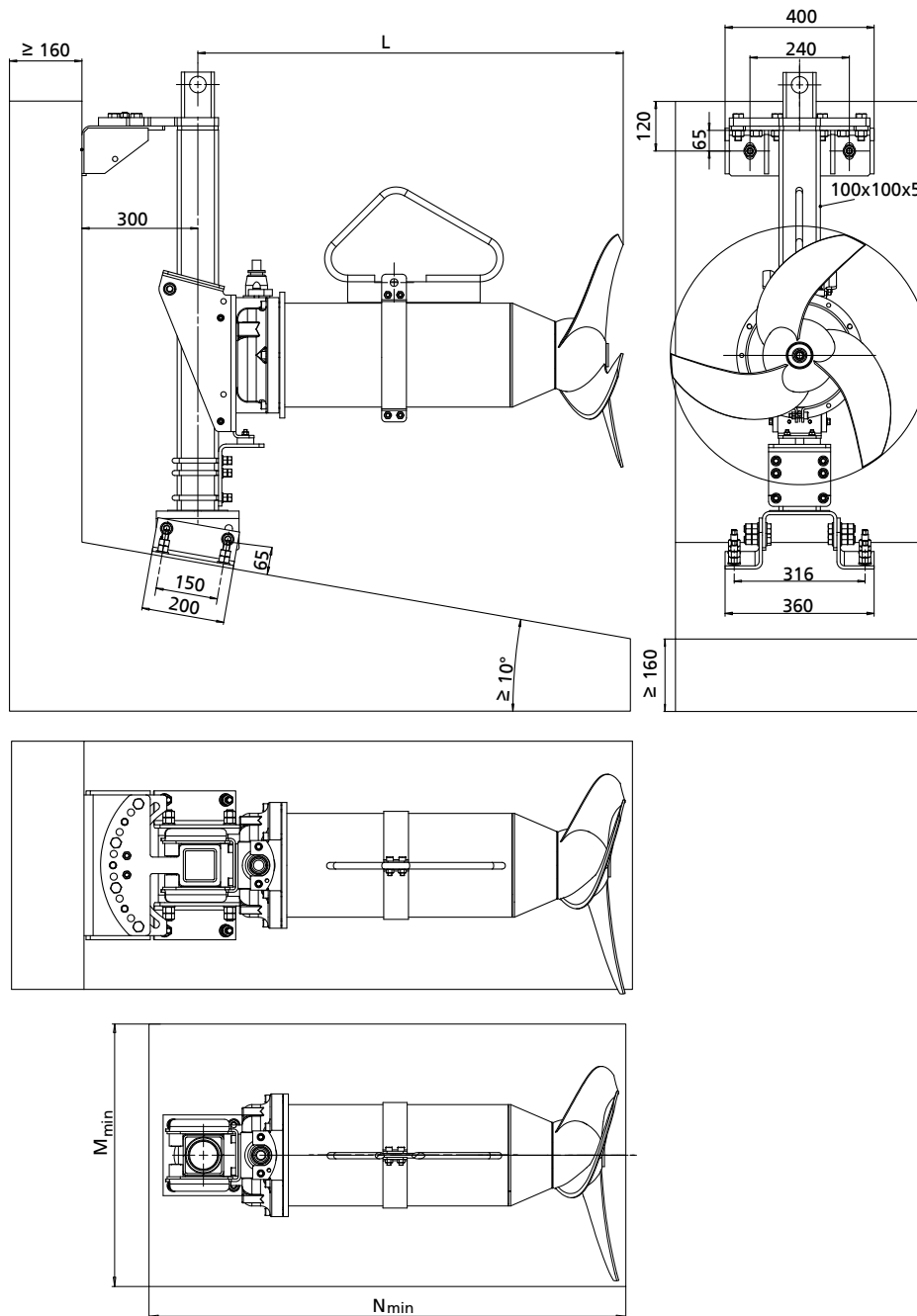

Installation with accessories set 22 - Amamix 400 (size 4135 only) / 600

Dimensions [mm]

Ø D	Motor housing material	L	M _{min}	N _{min}
400	G	783	460	1150
400	C	780	460	1150
600	G	949	700	1310
600	C	949	700	1390

For mounting at the top of the tank wall and at the bottom of the tank wall or on an inclined floor (10° - 90°), level-adjustable and with horizontal swivelling option

Overview of range

Installation with accessories set 22: mounted at the top of the tank wall and at the bottom of the tank wall or on an inclined floor (10° - 90°)

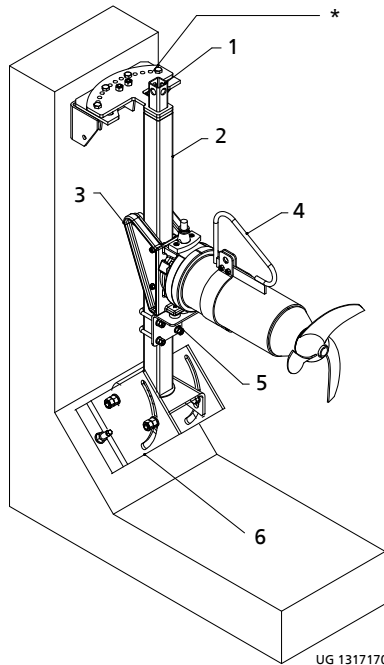

UG 1317170

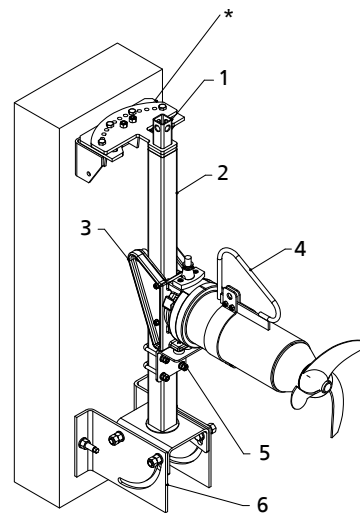

UG 1317172

Installation example: mounted on an inclined tank floor (10° - 90°)

Installation example: mounted on the tank wall

*	Swivelling option through 45° to the left and right around the guide rail axis (in increments of 7.5°)	4	Bail (optional)
1	Upper holder	5	Retaining bracket for guide rail
2	Guide rail ⁵⁷⁾	6	Lower holder
3	Guide bracket for guide rail		

Overview of standard accessories set 22: mounted at the top of the tank wall and at the bottom of the tank wall or on an inclined floor (10° - 90°)

Description	Amamix				Material	Mat. No.	[kg]		
	200	300	400	600					
	G	C	G	C					
Upper holder for guide rail 60 x 60 x 3 mm, incl. 2 chemical anchors	X	X	X	X	-	-	1.4301	01306260	8.9
Upper holder for guide rail 60 x 60 x 3 mm, incl. 2 chemical anchors	X	X	X	X	-	-	1.4571	01306261	8.9
Upper holder for guide rail 100 x 100 x 5 mm, incl. 2 chemical anchors	-	-	-	X	X	X	1.4301	01313458	23.23
Upper holder for guide rail 100 x 100 x 5 mm, incl. 2 chemical anchors	-	-	-	X	X	X	1.4571	01313459	23.23
Guide rail	(⇒ Page 64)								
Guide bracket for guide rail 60 x 60 x 3 mm ⁵⁸⁾	X	-	X	-	-	-	EN-GJL-250	19203139	6.83
Guide bracket for guide rail 60 x 60 x 3 mm ⁵⁹⁾	-	-	-	X	-	-	EN-GJL-250	01307155	10.5
Guide bracket for guide rail 60 x 60 x 3 mm	-	X	-	X	-	-	1.4571	19202241	3.4
Guide bracket for guide rail 60 x 60 x 3 mm	-	-	-	-	X	-	1.4571	01307156	7
Guide bracket for guide rail 100 x 100 x 5 mm	-	-	-	-	-	X	EN-GJL-250	19556700	17
Guide bracket for guide rail 100 x 100 x 5 mm ⁶⁰⁾	-	-	-	X	-	-	EN-GJL-250	19556701	13
Guide bracket for guide rail 100 x 100 x 5 mm	-	-	-	-	X	-	1.4571	19202242	8.79

57) Guide rail 60 x 60 x 3 mm for Amamix 200/300/400 (not included in KSB's general scope of supply)

58) Optional: guide bracket for guide rail 60 x 60 x 3 mm made of 1.4571 (19202241)

59) Optional: guide bracket for guide rail 60 x 60 x 3 mm made of 1.4571 (01307156)

60) Optional: guide bracket for guide rail 100 x 100 x 5 mm made of 1.4571 (19202242)

Description	Amamix								Material	Mat. No.	[kg]
	200		300		400		600				
	G	C	G	C	G	C	G	C			
Retaining bracket for guide rail 60 x 60 x 3 mm	X	X	X	X	X	X	-	-	1.4301	01109104	1.5
Retaining bracket for guide rail 60 x 60 x 3 mm	X	X	X	X	X	X	-	-	1.4571	19202369	1.5
Retaining bracket for guide rail 100 x 100 x 5 mm	-	-	-	-	X	X	X	X	1.4301	01129810	3.5
Retaining bracket for guide rail 100 x 100 x 5 mm	-	-	-	-	X	X	X	X	1.4571	19202370	3.5
Lower holder for guide rail 60 x 60 x 3 mm, incl. 4 chemical anchors	X	X	X	X	X	X	-	-	1.4301	01129731	13.27
Lower holder for guide rail 60 x 60 x 3 mm, incl. 4 chemical anchors	X	X	X	X	X	X	-	-	1.4571	01129732	13.27
Lower holder for guide rail 100 x 100 x 5 mm, incl. 4 chemical anchors	-	-	-	-	X	X	X	X	1.4301	01314360	26.52
Lower holder for guide rail 100 x 100 x 5 mm, incl. 4 chemical anchors	-	-	-	-	X	X	X	X	1.4571	01314362	26.52

Installation of accessories set 22 - Amamix 200 / 300 / 400 (except size 4135)

For mounting at the top of the tank wall and at the bottom of the tank wall or on an inclined floor (10° - 90°), level-adjustable and with horizontal swivelling option.

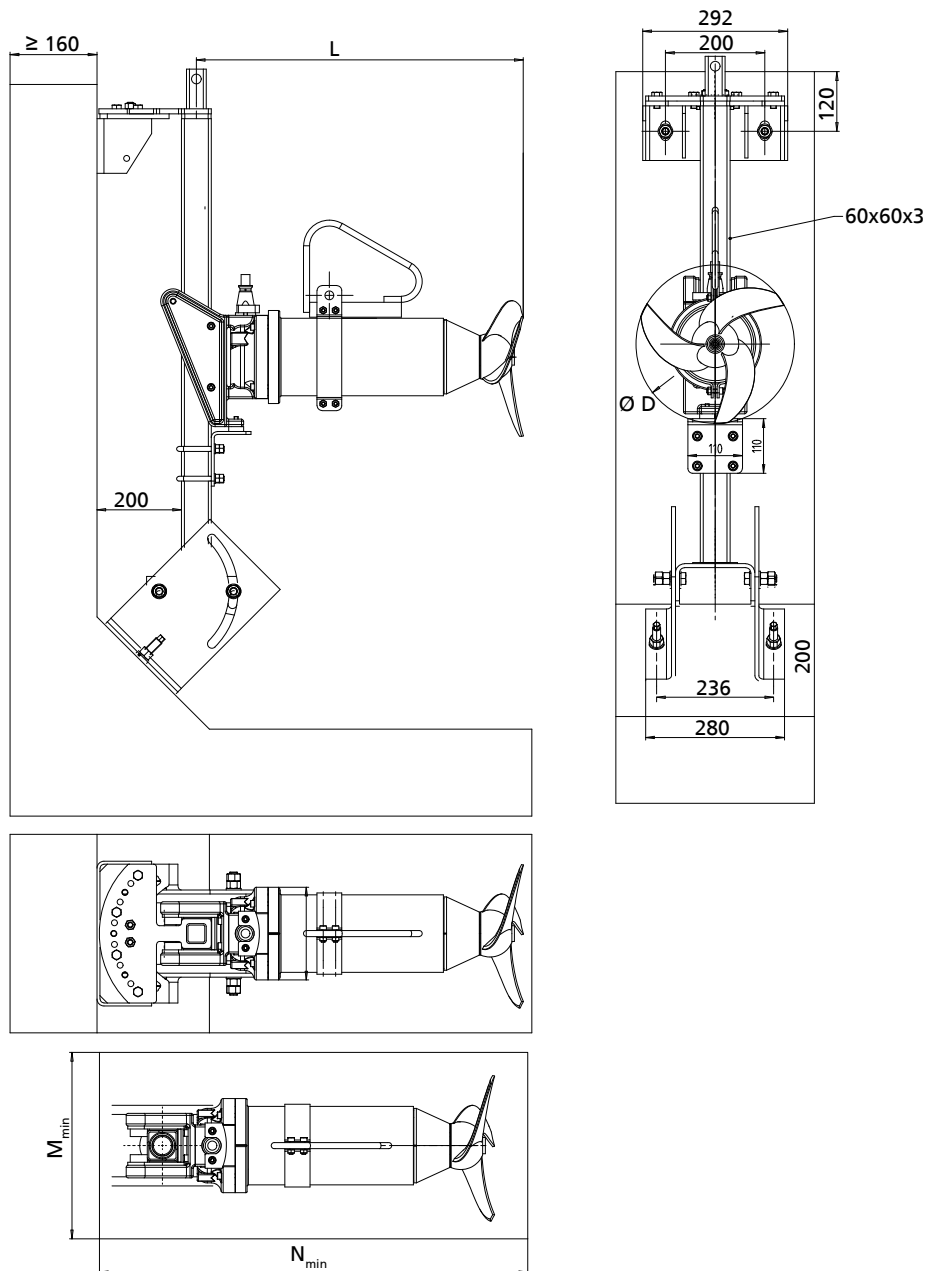

Installation with accessories set 22 - Amamix 200 / 300 / 400 (except size 4135)

Dimensions [mm]

Ø D	Motor housing material	L	M _{min}	N _{min}
200	G	524	275	780
200	C	520	275	780
300	G	659	375	910
300	C	655	375	910
400	G	844	460	1050
400	C	844	460	1050

Installation of accessories set 22 - Amamix 400 (size 4135 only) / 600

For mounting at the top of the tank wall and at the bottom of the tank wall or on an inclined floor (10° - 90°), level-adjustable and with horizontal swivelling option.

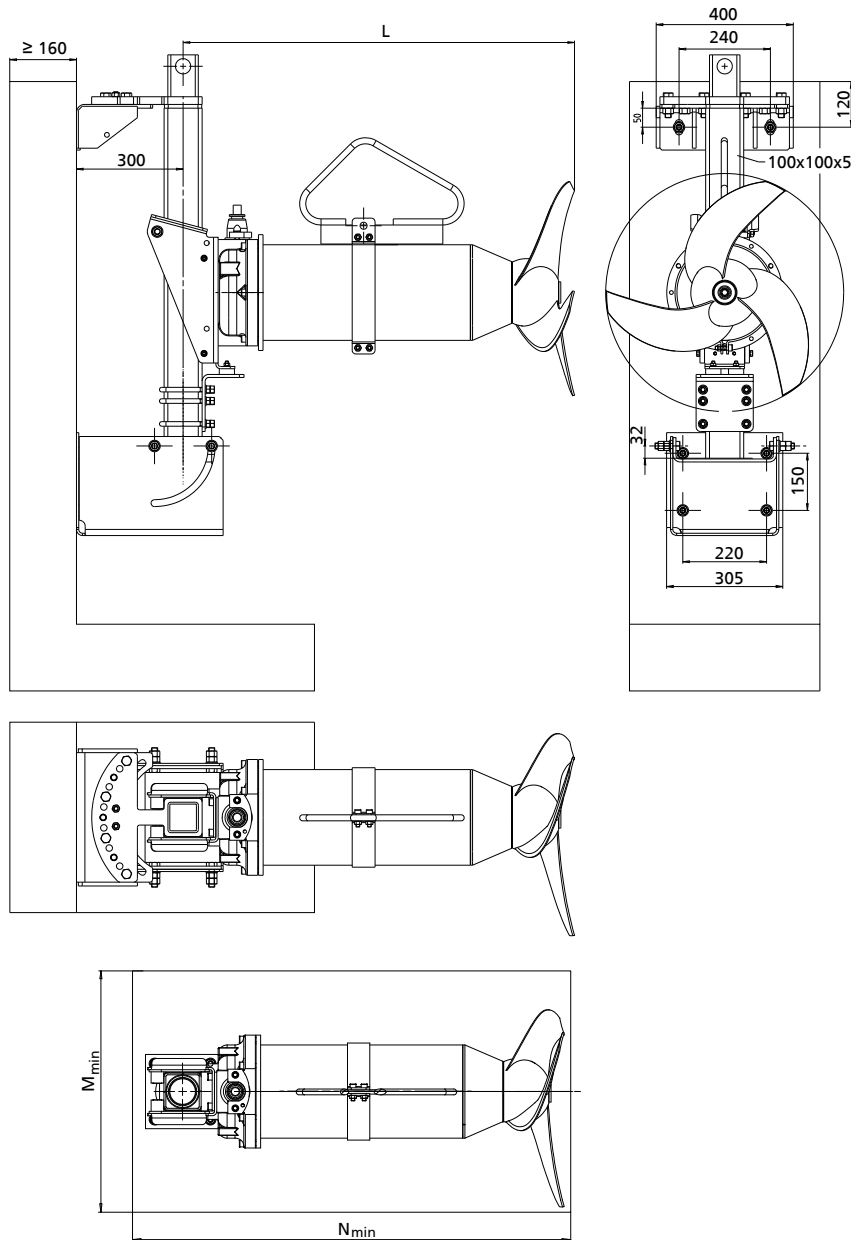

Installation with accessories set 22 - Amamix 400 (size 4135 only) / 600

Dimensions [mm]

Ø D	Motor housing material	L	M _{min}	N _{min}
400	G	783	460	1150
400	C	780	460	1150
600	G	949	700	1310
600	C	949	700	1390

Middle support for 60 x 60 x 3 mm or 100 x 100 x 5 mm guide rail for large installation depths

Overview of range

Installation with accessories set 22: mounted middle support for guide rail

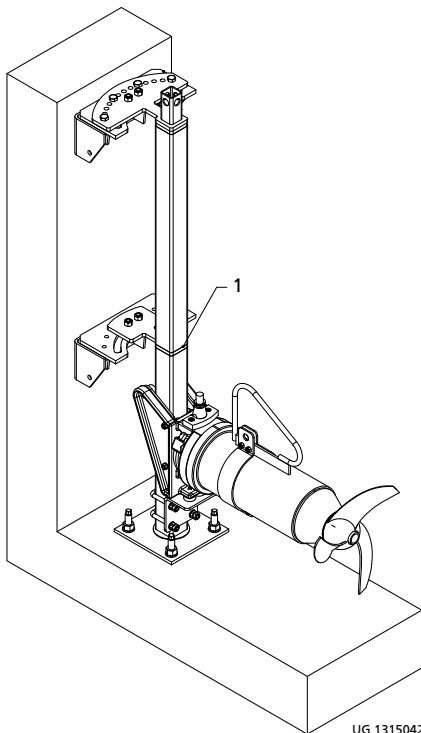

Amamix 200, 300, 400 with guide rail 60 x 60 x 3 mm

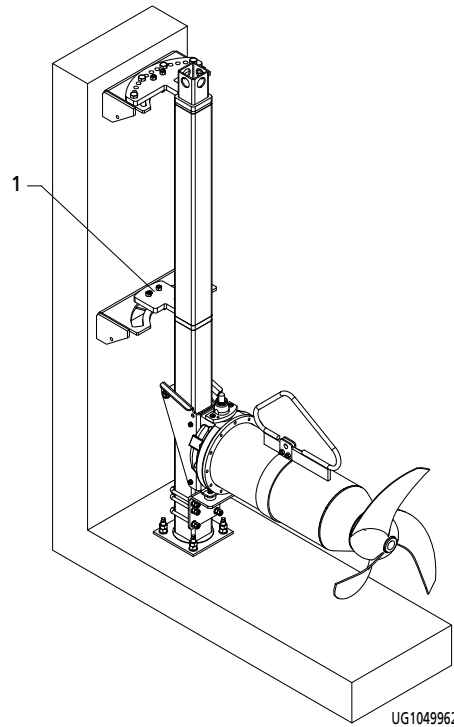

Amamix 400, 600 with guide rail 100 x 100 x 5 mm

1 Middle support

For installation depths > 6 m a middle support for the guide rail must be fitted on the tank wall. Middle supports are not required for installation depths of up to 6 m. However, if the set jet direction and tank wall reflections result in increased forces acting on the guide rail and upper and lower holders, a middle support must be fitted.

Overview of standard accessories set 22: middle support

Description	Amamix								Material	Mat. No.	[kg]
	200		300		400		600				
	G	C	G	C	G	C	G	C			
Middle support for guide rail 60 x 60 x 3 mm, incl. 2 chemical anchors	X	X	X	X	X	X	-	-	1.4301	01306324	7.7
Middle support for guide rail 60 x 60 x 3 mm, incl. 2 chemical anchors	X	X	X	X	X	X	-	-	1.4571	01306325	7.7
Middle support for guide rail 100 x 100 x 5 mm, incl. 2 chemical anchors	-	-	-	-	X	X	X	X	1.4301	01313462	19.26
Middle support for guide rail 100 x 100 x 5 mm, incl. 2 chemical anchors	-	-	-	-	X	X	X	X	1.4571	01313463	19.26

Installation of accessories set 22 - Amamix 200 / 300 / 400 (except size 4135)

Middle support for guide rail 60 x 60 x 3, for large installation depths.

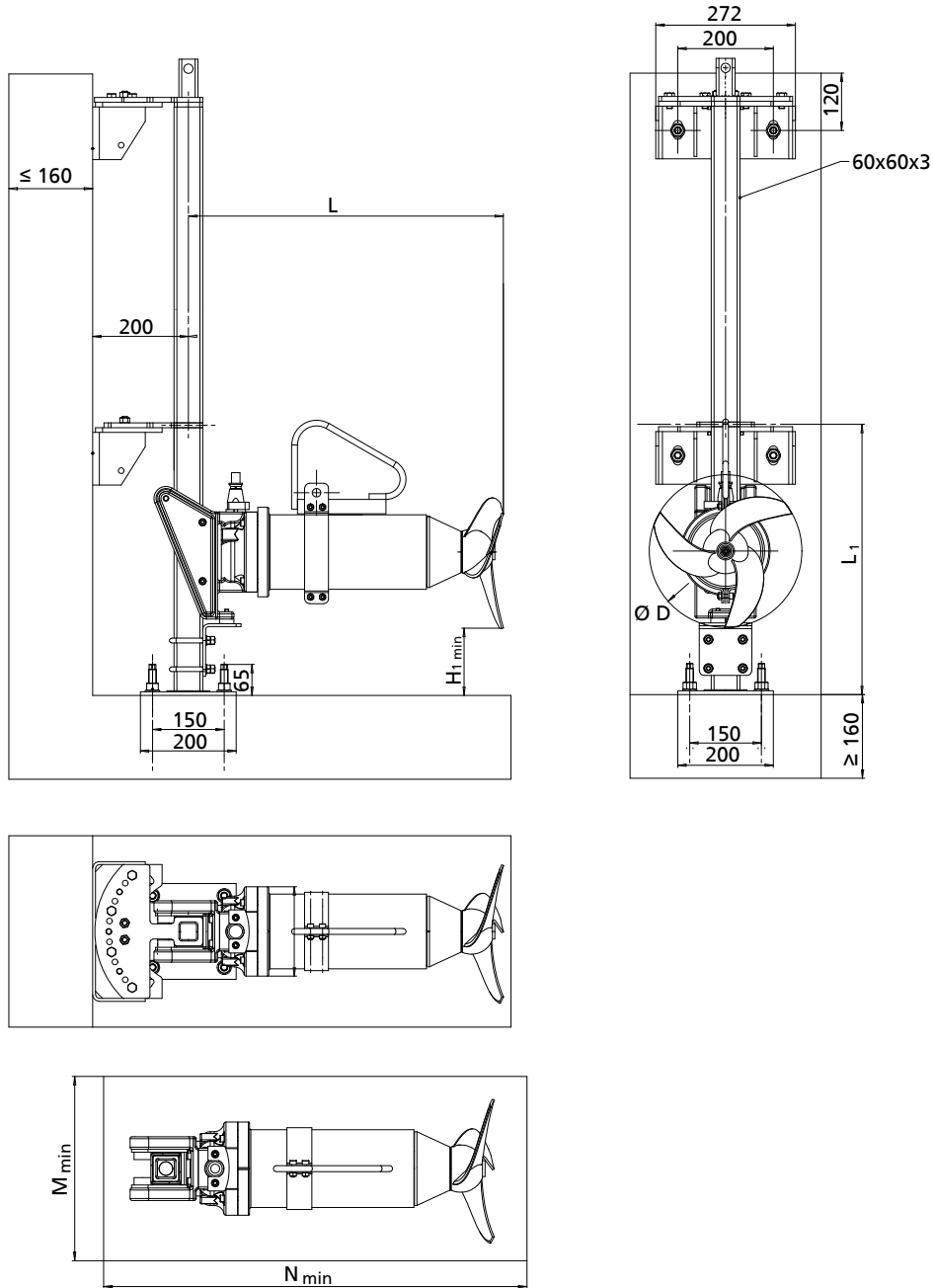

Installation with accessories set 22 - Amamix 200 / 300 / 400 (except size 4135)

Dimensions [mm]

Ø D	Motor housing material	H _{1 min}	L	M _{min}	N _{min}
200	G	120	524	275	780
200	C	120	520	275	780
300	G	150	659	375	910
300	C	150	655	375	910
400	G	200	844	460	1050
400	C	200	844	460	1050

Installation of accessories set 22 - Amamix 400 (size 4135 only) / 600

Middle support for guide rail 100 x 100 x 5, for large installation depths

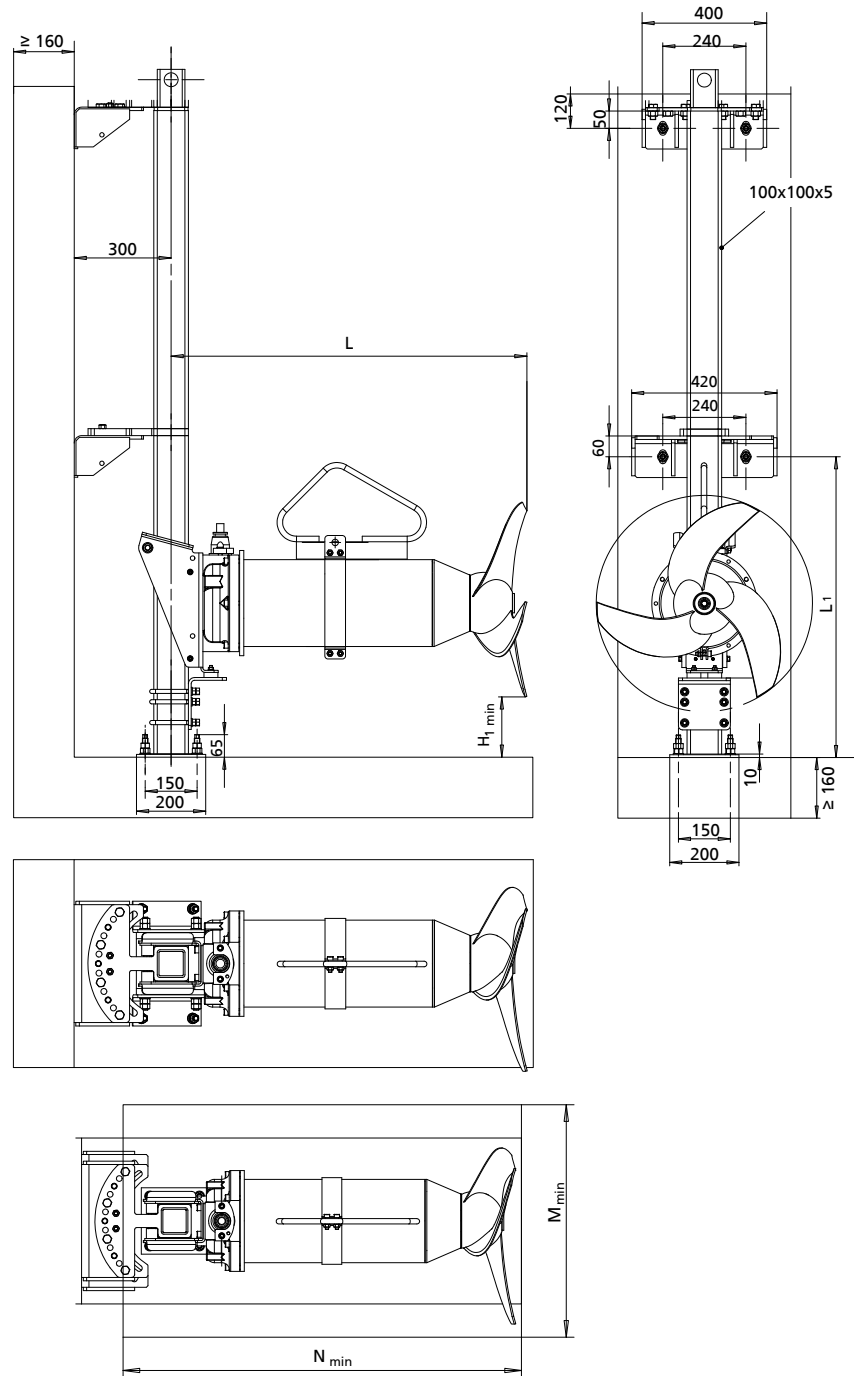

Installation with accessories set 22 - Amamix 400 (size 4135 only) / 600

Dimensions [mm]

$\varnothing D$	Motor housing material	$H_1 \text{ min}$	L_{max}	M_{min}	N_{min}
400	G	205	783	460	1150
400	C	205	780	460	1150
600	G	315	949	700	1310
600	C	315	949	700	1390

Pitch adapter

General information

The guide bracket for the guide rail does not allow an inclined mixer position relative to the guide rail axis.

For duties requiring an upward or downward inclination of the submersible mixer a pitch adapter is required. The pitch adapter is fitted between the motor housing cover and the guide bracket. It enables the requisite inclination of the submersible mixer axis in increments of 10°, from 40° upwards to 40° downwards.

Exception:

Amamix 200 C/G - max. downward pitch of 10°⁶¹⁾

Amamix 600 C - max. upward or downward pitch of 30°

Amamix 600 G - max. upward or downward pitch of 15° or 30°⁶²⁾

Amamix 200 only allows a downward pitch of up to 10°.

For variants with motor housing material stainless steel, the pitch adapter can be mounted on the guide bracket (in material 1.4571) without any problems. For variants with motor housing material grey cast iron, the pitch adapter cannot be mounted on the guide bracket (in EN-GJL-250) of Amamix 200/300/400. The following guide brackets (in material 1.4571) must be used in this case:

Description	Amamix						Material	Mat. No.	[kg]
	200		300		400 ⁶³⁾				
	G	C	G	C	G	C			
Guide bracket for guide rail 60 x 60 x 3 mm	X	-	X	-	-	-	1.4571	19202241	3.4
Guide bracket for guide rail 60 x 60 x 3 mm	-	-	-	-	X	-	1.4571	01307156	7
Guide bracket for guide rail 100 x 100 x 5 mm	-	-	-	-	-	X	1.4571	19202242	8.79

When the submersible mixer is pitched downwards it may not be possible to shift the supporting clamp towards the motor housing cover far enough to still allow smooth lifting and lowering of the mixer (approx. 5° inclination of the guide bracket relative to the guide rail). In such cases, the supporting strap shown must be used (included in the pitch adapter assembly), which provides the user with a suitable attachment point. The attachment point is determined by the specified hole.

Selecting the attachment hole in the supporting strap required for downward pitch

1. Example: submersible mixer V222. / 1 4 UDG
2. V2... / 1 4 ...: see "Pitch 20°" column
3. See column "Tu": 2. L*

A supporting strap is required. Lifting tackle must be attached to the second hole from the left.

The power cable is protected against damage (chafing) by the supplied cable sleeve and cable ties.

⁶¹⁾ With Amamix 200, the maximum pitch is 10°, as the motor housing is relatively short and does not allow an optimum position of the supporting strap. A pitch angle of 20°/30°/40° can be achieved with a specially designed supporting clamp (on request).

⁶²⁾ The pitch direction (upward or downward) must always be specified in the purchase order.

⁶³⁾ Except size 4135

Overview of range

Amamix 200, 300, 400 (motor housing material grey cast iron, stainless steel)
Amamix 600 (motor housing material stainless steel)

Amamix 600 (motor housing material grey cast iron)

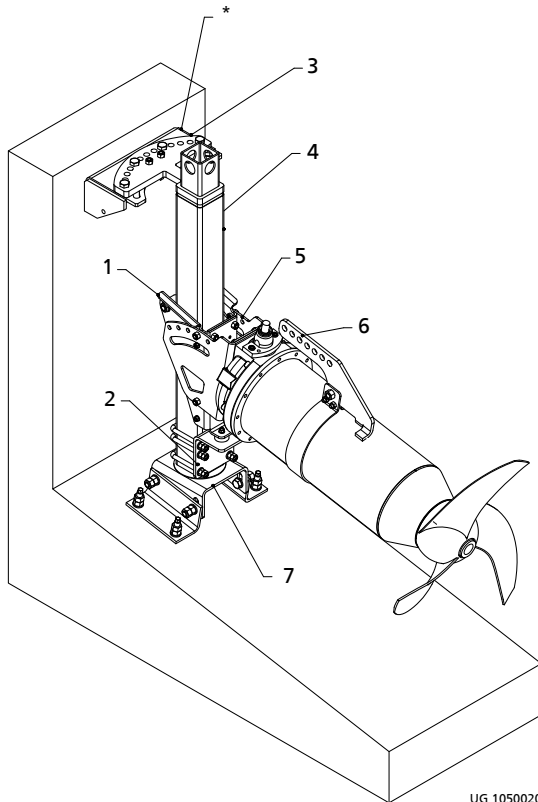

UG 1050020

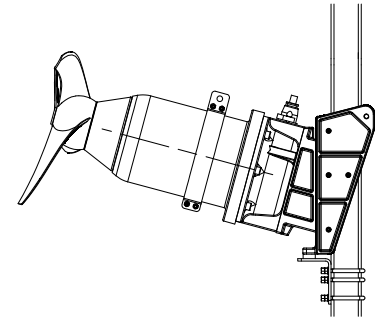

UG 1126952

Installation example: 15° upward pitch

Mounted on sloping tank floor (0.5° - 10°) with pitch adapter fitted between guide bracket and motor housing cover (downward pitch)

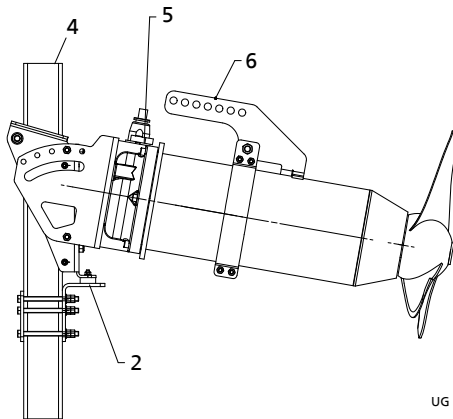

UG 1058974

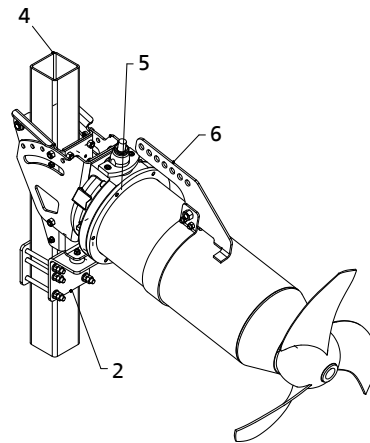

Side view/isometric view

*	Swivelling option through 45° to the left and right around the guide rail axis (in increments of 7.5°)	4	Guide rail
1	Guide bracket	5	Pitch adapter
2	Retaining bracket	6	Supporting strap ⁶⁴⁾
3	Upper holder	7	Lower guide rail holder

64) The supporting strap is required for downward pitch only.

Overview of pitch adapters

Description	Amamix								Material	Mat. No.	[kg]
	200		300		400		600				
	G	C	G	C	G	C	G	C			
Pitch adapter	X	X	X	X	X	X	-	-	1.4571	19554654	4
	-	-	-	-	X ⁶⁵⁾	X ⁶⁵⁾	-	X ⁶⁶⁾	1.4571	19554656	9
	-	-	-	-	-	-	-	X ⁶⁷⁾	1.4571	19554655	9
	-	-	-	-	-	-	X ⁶⁸⁾	-	EN-GJL-250	01137874	12.64
	-	-	-	-	-	-	X ⁶⁹⁾	-	EN-GJL-250	01137876	20.35

-
- 65) Propeller 4135 only
 - 66) With motor 4 12 only
 - 67) With motor 8 12 only
 - 68) 15°
 - 69) 30°

Installation with downward pitch

For accessories set 22 - Amamix 200 - 600

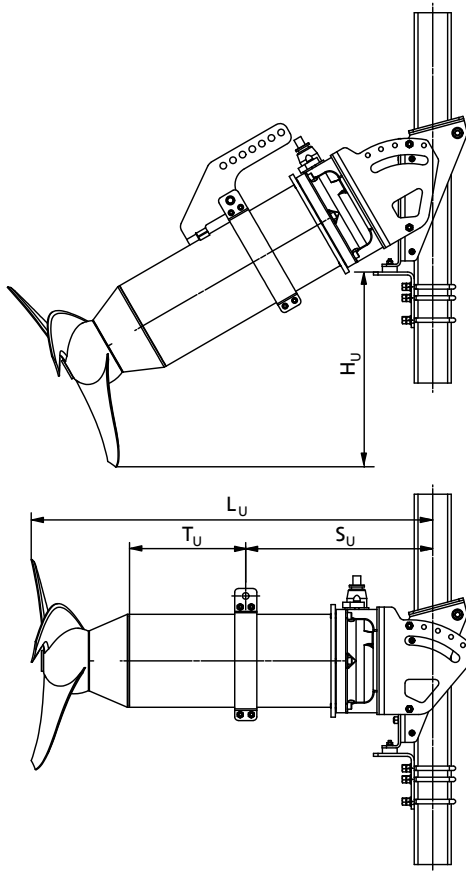

Downward pitch adjustment

Downward pitch adjustment by 0°, 10°, 20°, 30°, 40°

Size	Pitch = 0°				Pitch = 10°				Pitch = 20°				Pitch = 30°				Pitch = 40°				
	H _U	L _U	S _U	T _U	H _U	L _U	S _U	T _U	H _U	L _U	S _U	T _U	H _U	L _U	S _U	T _U	H _U	L _U	S _U	T _U	
	[mm]																				
V2... / 1 4...	< 0	560	225	265	30	585	240	1.L	70)	70)	70)	70)	70)	70)	70)	70)	70)	70)	70)	70)	70)
V2... / 2 4...	< 0	560	230	260	30	585	585	1.L	70)	70)	70)	70)	70)	70)	70)	70)	70)	70)	70)	70)	70)
C2... / 1 4...	< 0	560	230	230	40	585	250	245	70)	70)	70)	70)	70)	70)	70)	70)	70)	70)	70)	70)	70)
C2... / 2 4...	< 0	560	235	225	40	585	250	245	70)	70)	70)	70)	70)	70)	70)	70)	70)	70)	70)	70)	70)
C29... / 0 6...	13	709	275	255	150	744	285	280	245	759	285	305	335	754	285	2.L	415	729	270	4.L	
C32... / 2 6...	13	709	275	255	150	744	285	280	245	759	285	305	335	754	285	2.L	415	729	270	4.L	
C37... / 3 8...	25	858	340	310	165	898	345	340	275	918	355	1.L	380	913	340	3.L	470	883	330	5.L	
C41... / 4 8...	25	858	340	310	165	898	345	340	275	918	355	1.L	380	913	340	3.L	470	883	330	5.L	
C57... / 4 12...	100	1004	400	290	305	1074	415	325	430	1114	420	360	540	1129	420	390	71)	71)	71)	71)	
C63... / 8 12...	100	1129	460	350	325	1194	475	385	470	1229	475	420	600	1234	470	455	71)	71)	71)	71)	

Downward pitch adjustment of 0°, 15°, 30°

Size	Pitch = 0°				Pitch = 15°				Pitch = 30°				
	H _U	L _U	S _U	T _U	H _U	L _U	S _U	T _U	H _U	L _U	S _U	T _U	
	[mm]												
C57.../C63...	/ 6 12...	85	946	393	280	350	950	700	300	486	1048	579	320
	/ 10 12...	85	946	393	280	350	950	700	300	486	1048	579	320

70) On request only

71) Max. permissible pitch: 30°

Installation with upward pitch

For accessories set 22 - Amamix 200 - 600

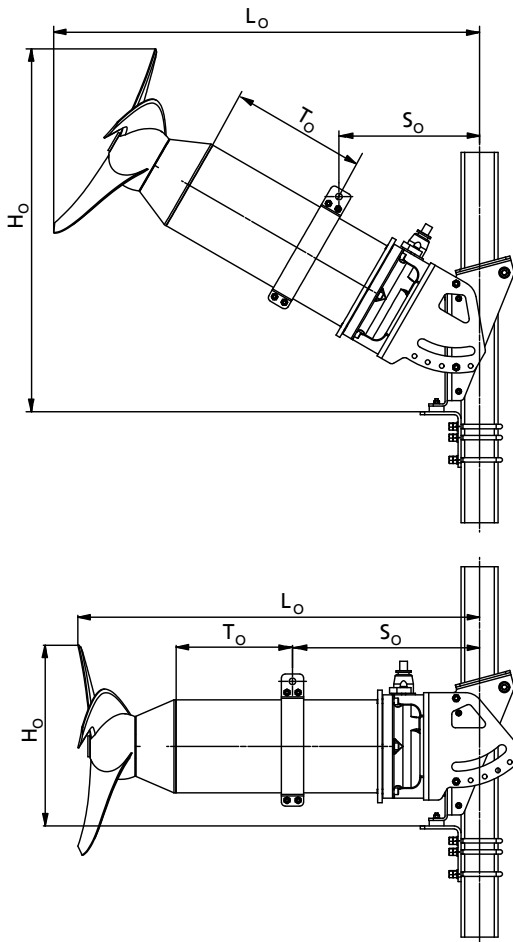

Upward pitch adjustment

Upward pitch adjustment by 0°, 10°, 20°, 30°, 40°

Size	Pitch = 0°				Pitch = 10°				Pitch = 20°				Pitch = 30°				Pitch = 40°			
	H ₀	L ₀	S ₀	T ₀	H ₀	L ₀	S ₀	T ₀	H ₀	L ₀	S ₀	T ₀	H ₀	L ₀	S ₀	T ₀	H ₀	L ₀	S ₀	T ₀
	[mm]																			
V2... / 1 4...	260	560	225	265	350	585	240	245	440	595	250	220	520	585	255	190	595	560	260	150
V2... / 2 4...	260	560	230	260	350	585	245	240	440	595	255	215	520	585	260	185	595	560	260	150
C2... / 1 4...	270	560	230	230	360	585	250	210	450	595	255	190	530	590	260	165	600	565	260	135
C2... / 2 4...	270	560	235	225	360	585	255	205	450	595	260	185	530	590	265	160	600	565	260	130
C29... / 0 6...	313	709	275	255	470	744	295	230	570	759	315	200	655	754	315	170	735	729	305	140
C32... / 2 6...	313	709	275	255	470	744	295	230	570	759	315	200	655	754	315	170	735	729	305	140
C37... / 3 8...	385	858	340	310	630	898	360	285	740	918	380	250	845	913	290	210	935	883	390	160
C41... / 4 8...	385	858	340	310	630	898	360	285	740	918	380	250	845	913	290	210	935	883	390	160
C57... / 4 12...	530	1004	400	290	765	1074	425	260	890	1114	440	225	1000	1129	445	185	72)	72)	72)	72)
C63... / 8 12...	530	1129	460	350	785	1194	485	320	930	1229	500	280	1060	1234	505	235	72)	72)	72)	72)

Upward pitch adjustment of 0°, 15°, 30°

Size	Pitch = 0°				Pitch = 15°				Pitch = 30°				
	H ₀	L ₀	S ₀	T ₀	H ₀	L ₀	S ₀	T ₀	H ₀	L ₀	S ₀	T ₀	
	[mm]												
C57.../C63...	/ 6 12...	545	946	393	280	800	1079	400	250	1050	1116	360	230
	/ 10 12...	545	946	393	280	800	1079	400	250	1050	1116	360	230

72) Max. permissible pitch: 30°

Options: Amamix 200, 300 with guide bracket for guide rail 100 x 100 x 5 mm

The standard version of Amamix 200, 300 with accessories set 22 is designed for a 60 x 60 x 3 mm guide rail (new installations). If a 100 x 100 x 5 mm guide rail has been specified, or if a 100 x 100 x 5 mm guide rail is already installed (e.g. in the case of KSB replacement units), Amamix 200, 300 units can be equipped with the following guide brackets instead of the standard guide brackets:

Overview of guide brackets for Amamix 200, 300 with guide rail 100 x 100 x 5 mm

Description	Amamix				Material	Mat. No.	[kg]
	200		300				
	G	C	G	C			
Guide bracket for guide rail 100 x 100 x 5 mm	X	-	X	-	EN-GJL-250	19556701	13
Guide bracket for guide rail 100 x 100 x 5 mm	○ ⁷³⁾	X	○ ⁷³⁾	X	1.4571	19202242	8.79

The guide brackets are already provided with the holes required for fastening the Amamix 200, 300 mixer.

Guide bracket mounted on motor housing cover with socket head cap screws

Description	Quantity	Thread	Tightening torque
Socket head cap screws	4	M8	17 Nm

Compared to the technical data of the standard version (guide bracket for guide rail 60 x 60 x 3 mm), the complete unit weight, incl. guide bracket and 10-metre power cable, will be increased by 9.1 kg (motor housing material grey cast iron) or 5.1 kg (motor housing material stainless steel). A heavier guide bracket also results in different dimensions and a different position of the supporting clamp.

Dimensions of guide bracket for guide rail 100 x 100 x 5 mm

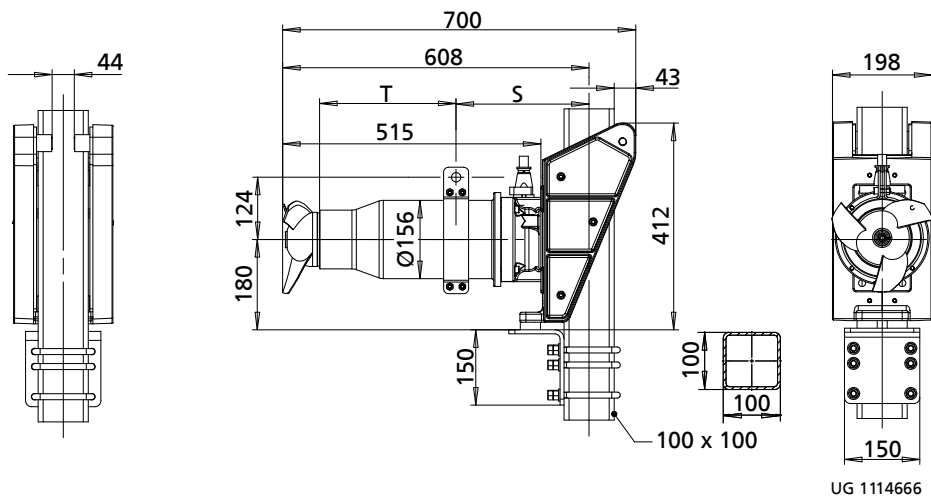

Amamix 200 G: S = 215 / T = 270, motor 1 4 = 43 kg, motor 2 4 = 43.5 kg

73) Optional

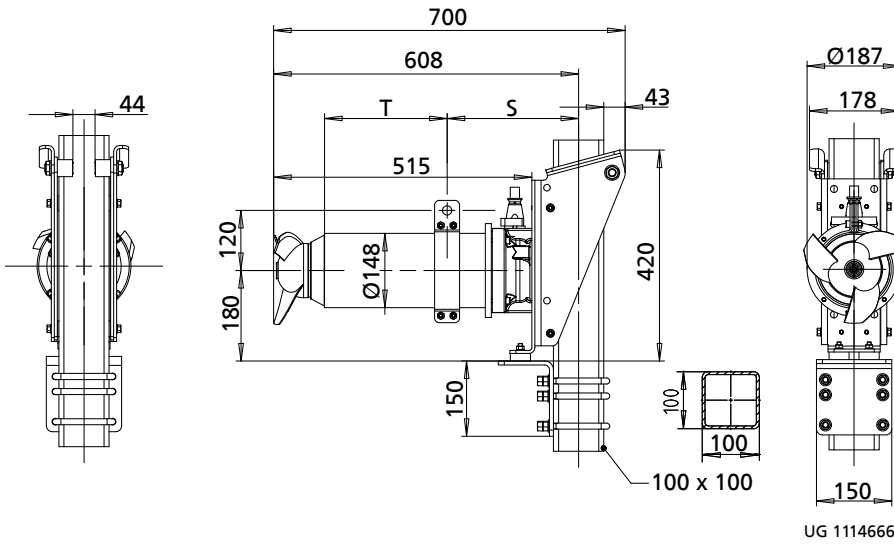

Amamix 200 C: S = 215 / T = 240 (motor 1 4) S = 220 / T = 235 (motor 2 4), motor 1 4 = 36.5 kg, motor 2 4 = 39 kg

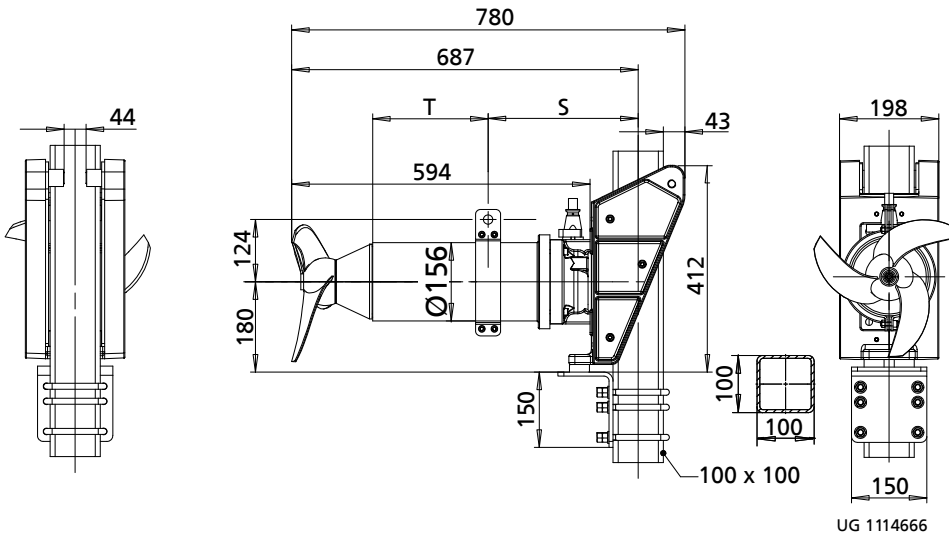

Amamix 300 G: S = 265 / T = 260, motor 0 6 / 2 6 = 55 kg

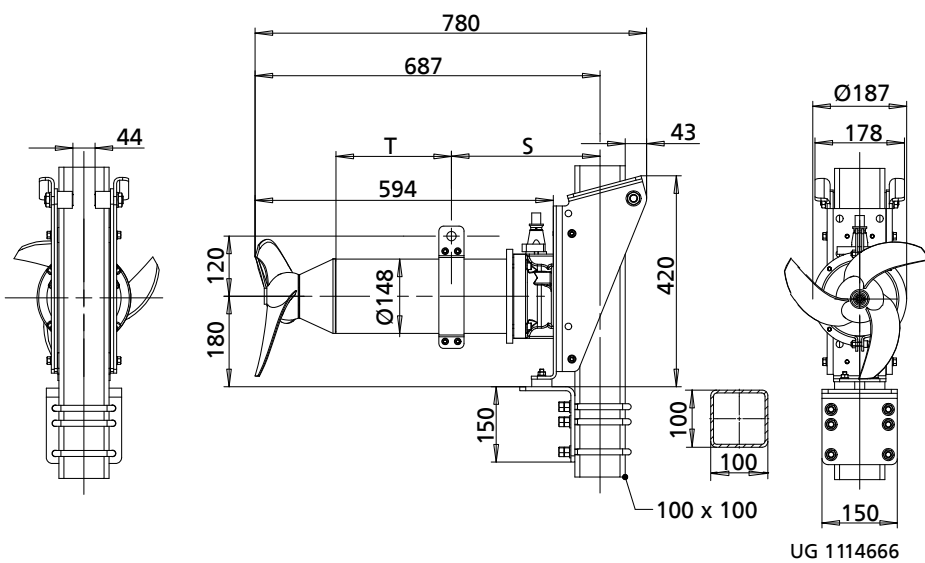

Amamix 300 C: S = 265 / T = 260, motor 0 6 / 2 6 = 48.5 kg

Forcing screws

Forcing screws

Size	Forcing screw		Mat. No.	[kg]
200	M16 x 60		11197135	0,1
300			11197135	0,1
400			11197135	0,1
600	M20 x 95		11197784	0,25

Guide rails

Overview of guide rails

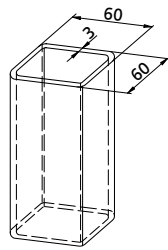

Guide rail 60 x 60 x 3 mm

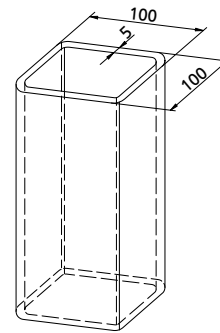

Guide rail 100 x 100 x 5 mm

Overview of guide rails

Description	Length	Amamix								Material	Mat. No.	[kg]
		200		300		400		600				
	[m]	G	C	G	C	G	C	G	C			
Guide rail 60 x 60 x 3 mm	1,5	X	X	X	X	X	X	-	-	1.4301	11307851	7.85
Guide rail 60 x 60 x 3 mm	1,5	X	X	X	X	X	X	-	-	1.4571	11307852	7.85
Guide rail 60 x 60 x 3 mm	3,0	X	X	X	X	X	X	-	-	1.4301	11304010	15.7
Guide rail 60 x 60 x 3 mm	3,0	X	X	X	X	X	X	-	-	1.4571	11304011	15.7
Guide rail 60 x 60 x 3 mm	6,0	X	X	X	X	X	X	-	-	1.4301	11304596	31.3
Guide rail 60 x 60 x 3 mm	6,0	X	X	X	X	X	X	-	-	1.4571	11304597	31.3
Guide rail 100 x 100 x 5 mm	3,0	-	-	-	-	X	X	X	X	1.4301	11304598	43.2
Guide rail 100 x 100 x 5 mm	3,0	-	-	-	-	X	X	X	X	1.4571	11304599	43.2
Guide rail 100 x 100 x 5 mm	6,0	-	-	-	-	X	X	X	X	1.4301	11304600	86.4
Guide rail 100 x 100 x 5 mm	6,0	-	-	-	-	X	X	X	X	1.4571	11304601	86.4

Wear-resistant adapter

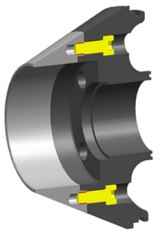

Wear-resistant adapter (available against a surcharge)

If the fluid handled contains sand or similar abrasive particles, combining adapter 721 with a screwed-on wear-resistant casing wear ring is recommended.

Materials: adapter

Component	Material	
	Standard design	Special design
Adapter	Polyurethane	Polyurethane
Casing wear ring	-	1.4021/hardened to HB400

i The wear-resistant adapter (special design) is available on request.

Cable support/carabine hook

Cable support

The cable support is used for supporting the power cable at the lifting rope or tank edge (one included in standard scope of supply; additional or spare cable supports available).

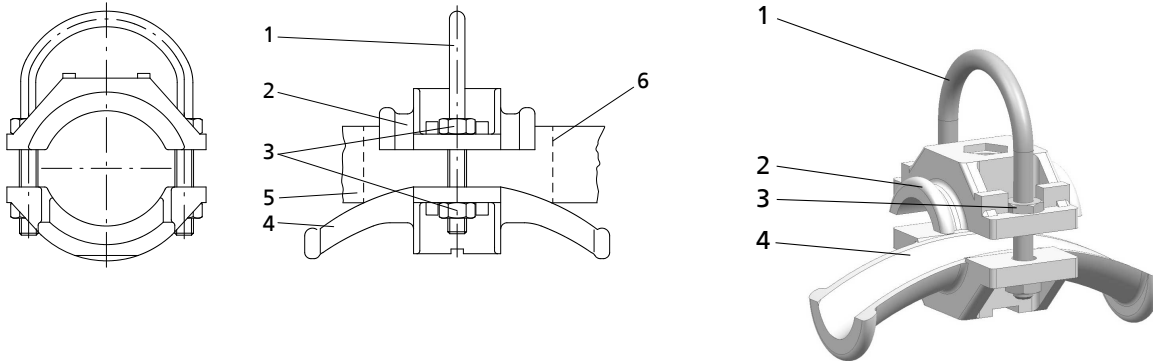
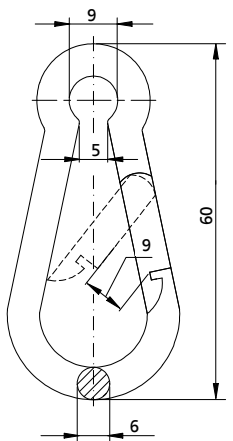

Illustration of cable support

1	Bail
2	Moulded part made of polypropylene
3	Hexagon nut made of A4
4	Moulded part made of polypropylene
5	Power cable with defined diameter ⁷⁴⁾
6	Rubber pad

i For power cable diameters ≤ 10 or 17 mm respectively a rubber pad is inserted to make sure the cable is clamped properly.

Carabine hook



0W 384695-00

Dimensions of carabine hook [mm]

⁷⁴⁾ Refer to the power cable data given in the motor catalogue.

Overview of cable supports/carabine hooks

Description	Suitable for														Material	Mat. No.	[kg]
	1 4	2 4	5 4	11 4	16 4	23 4	0 6	2 6	3 8	4 8	4 12	6 12	8 12	10 12			
Cable support, incl. carabine hooks	x ⁷⁵⁾	x ⁷⁵⁾	-	-	-	-	x ⁷⁵⁾	x ⁷⁵⁾	-	-	-	-	-	-	Cable support: plastic / A4, carabine hook: A4	1955522	0.06
Cable support, incl. carabine hooks	-	-	x ⁷⁶⁾	x ⁷⁶⁾	x ⁷⁶⁾	x ⁷⁶⁾	-	-	x ⁷⁶⁾	x ⁷⁶⁾	x ⁷⁶⁾	x ⁷⁶⁾	x ⁷⁶⁾	x ⁷⁶⁾	Cable support: plastic / A4, carabine hook: A4	1955523	0.09

75) Diameter of power cable Ø = 10-16 mm
 76) Diameter of power cable Ø = 17-25 mm

Scope of supply

Depending on the design variant the following components are included in the scope of supply:

Accessories of accessories set 6

- Stand for floor mounting



- Chemical anchors

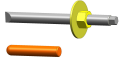

Accessories of accessories set 7

- Chemical anchors

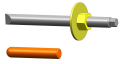

- Guide rail with guide rail extension if required



- Lower holder for mounting on the sump/tank wall or benching



- Upper holder

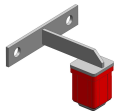

- Retaining bracket

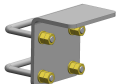

- Guide bracket Version C or version G, usually supplied fitted to the mixer

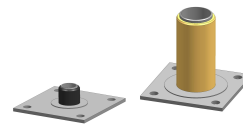
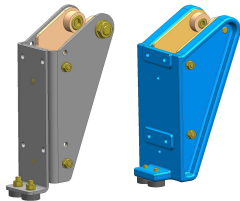

- Lower holder for mounting on a sloping tank floor (0.5° - 10°)

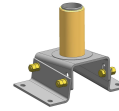

- Lower holder for mounting on an inclined tank floor or on the sump/tank wall (10° - 90°)

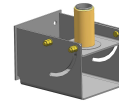

- Upper holder Version 60 x 60 or 100 x 100 mm



- Retaining bracket Version 60 x 60 mm or 100 x 100 mm

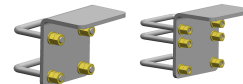

- Guide bracket Version C, version G, usually supplied fitted to the mixer

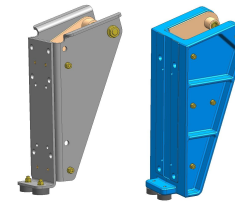

Special accessory - Middle support for guide rail



Special accessory - Supporting strap

Fastened to the mixer via the supporting clamp if a pitch adapter is used; usually fitted at the factory (included in the pitch adapter assembly)



Accessories of accessories set 22

- Chemical anchors

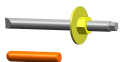

- Guide rail with guide rail extension if required



- Lower holder for mounting on a horizontal tank floor (0° - 0.5°) Version 60 x 60 or 100 x 100 mm

Special accessory - Bail

Fastened to the mixer via the supporting clamp; usually fitted at the factory



Special accessory - Pitch adapter

Usually fitted between the motor housing cover and the guide bracket at the factory



Special accessory - Pitch adapter for Amamix 600 G

Always fitted between the motor housing cover and the guide bracket at the factory

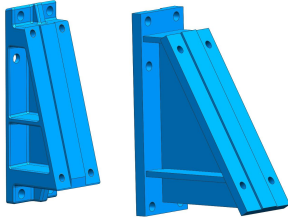

General assembly drawings with list of components

Amamix 200 - motor housing material stainless steel

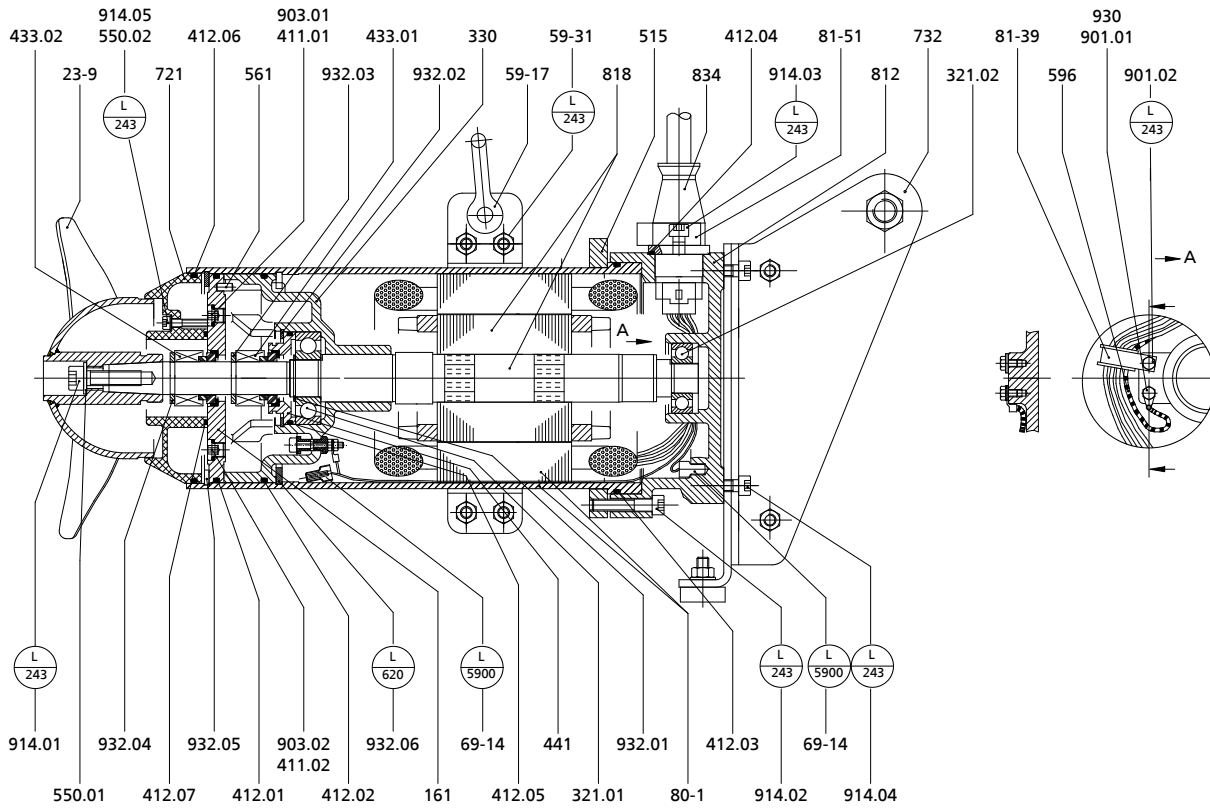

General assembly drawing of Amamix 200, motor housing material stainless steel

List of components of Amamix 200, motor housing material stainless steel

Part No.	Description	Part No.	Description
161	Casing cover	69-14	Leakage monitor
23-9	Axial propeller	721	Adapter
321	Radial ball bearing	732	Guide bracket (accessory)
330	Bearing bracket	80-1	Motor unit
411	Joint ring	81-39	Clamp
412	O-ring	81-51	Clamping element
433	Mechanical seal	812	Motor housing cover
441	Shaft seal housing	818	Rotor
515	Taper lock ring	834	Cable gland
550	Disc	901	Hexagon head bolt
561	Grooved pin	903	Screw plug
59-17	Shackle	914	Hexagon socket head cap screw
59-31	Supporting clamp	930	Safety device
596	Wire	932	Circlip

Amamix 200 - motor housing material grey cast iron

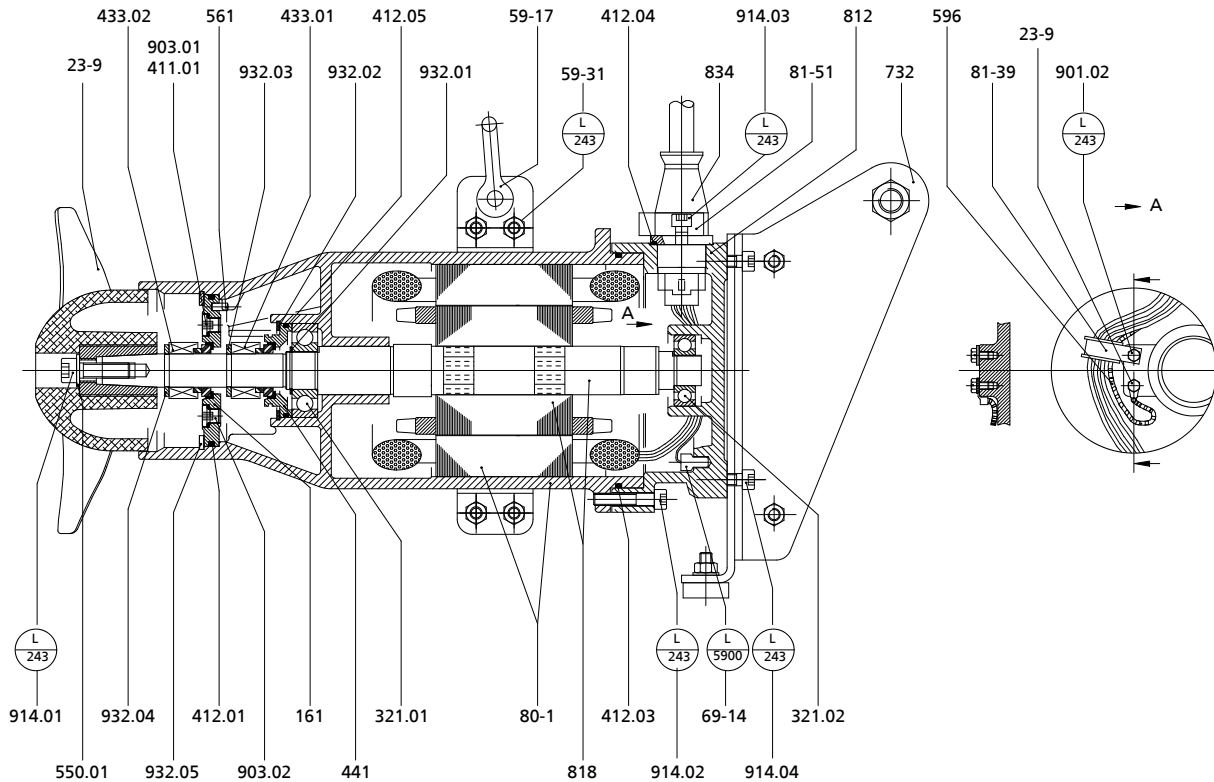

General assembly drawing of Amamix 200, motor housing material grey cast iron

List of components of Amamix 200, motor housing material grey cast iron

Part No.	Description	Part No.	Description
161	Casing cover	732	Guide bracket (accessory)
23-9	Axial propeller	80-1	Motor unit
321	Radial ball bearing	81-39	Clamp
411	Joint ring	81-51	Clamping element
412	O-ring	812	Motor housing cover
433	Mechanical seal	818	Rotor
441	Shaft seal housing	834	Cable gland
550	Disc	901	Hexagon head bolt
561	Grooved pin	903	Screw plug
59-17	Shackle	914	Hexagon socket head cap screw
59-31	Supporting clamp	930	Safety device
596	Wire (earth connection)	932	Circlip
69-14	Leakage monitor		

Amamix 300/400/600 - motor housing material stainless steel

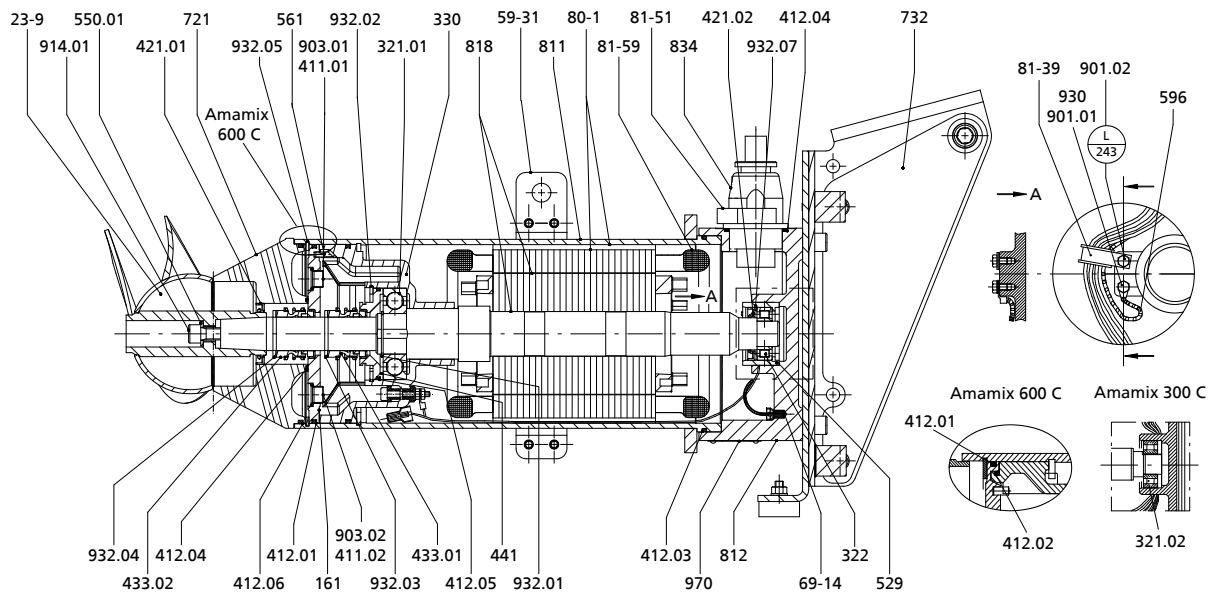

General assembly drawing of Amamix 300/400/600, motor housing material stainless steel

List of components of Amamix 300/400/600, motor housing material stainless steel

Part No.	Description	Part No.	Description
161	Casing cover	721	Adapter
23-9	Axial propeller	732	Guide bracket (accessory)
321	Radial ball bearing	80-1	Motor unit
322	Radial roller bearing	81-39	Clamp
330	Bearing bracket	81-51	Clamping element
411	Joint ring	81-59	Stator
412	O-ring	811	Motor housing
421	Lip seal	812	Motor housing cover
433	Mechanical seal	818	Rotor
441	Shaft seal housing	834	Cable gland
529	Bearing sleeve	901	Hexagon head bolt
550	Disc	903	Screw plug
561	Grooved pin	914	Hexagon socket head cap screw
59-31	Supporting clamp	930	Safety device
596	Wire (earth connection)	932	Circlip
69-14	Leakage monitor	970	Label/plate

Amamix 300/400/600 - motor housing material grey cast iron

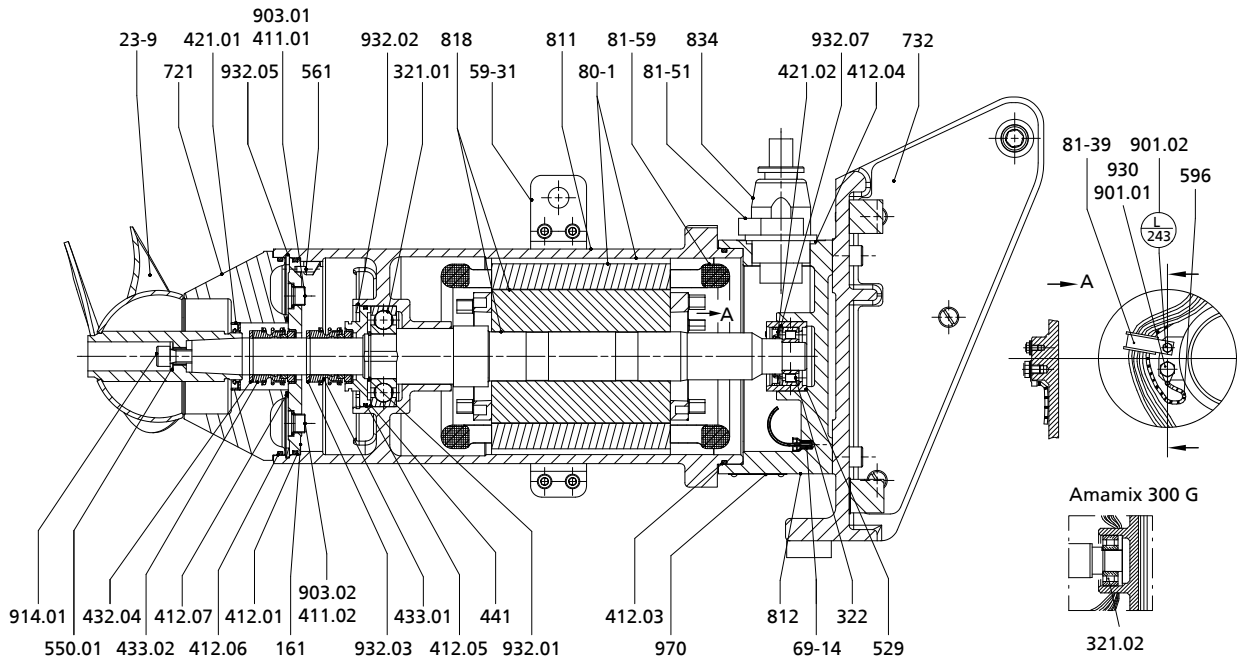

General assembly drawing of Amamix 300/400/600, motor housing material grey cast iron

List of components of Amamix 300/400/600, motor housing material grey cast iron

Part No.	Description	Part No.	Description
161	Casing cover	721	Adapter
23-9	Axial propeller	732	Guide bracket (accessory)
321	Radial ball bearing	80-1	Motor unit
322	Radial roller bearing	81-51	Clamping element
411	Joint ring	81-59	Stator
412	O-ring	811	Motor housing
421	Lip seal	812	Motor housing cover
433	Mechanical seal	818	Rotor
441	Shaft seal housing	834	Cable gland
529	Bearing sleeve	901	Hexagon head bolt
550	Disc	903	Screw plug
561	Grooved pin	914	Hexagon socket head cap screw
59-31	Supporting clamp	930	Safety device
596	Wire (earth connection)	932	Circlip
69-14	Leakage monitor	970	Label/plate

Enquiry sheet

To:
KSB Aktiengesellschaft
Turmstraße 92
06110 Halle/Saale (Germany)
Tel.: +49 345 4826-4879/4680
Fax: +49 345 4826-5107

From:

Company name	
Contact person	
Street/number	
Post/zip code, city	
Country	
Telephone number	
Fax number	
E-mail	

Project name

--

Mains frequency:

- 50 Hz
 60 Hz

Mains voltage:

U [V]	
-------	--

Fluid

Solids content:

[%]	
-----	--

Temperature:

T [°F]	
T [°C]	

Density:

[lbs/inch]	
[kg/m³]	

Viscosity (at shear rate):

[cp.]	
[mPas]	

Loss on ignition:

[%]	
-----	--

Sludge index:

[ml/g]	
--------	--

Explosion protection:

- Yes
 No

Type of fluid:

- Activated sludge
 Municipal sewage sludge (primary/secondary)
 Digested sludge
 Raw waste water
 Other:

Flow behaviour:

- Newtonian (e.g. water)
 Pseudoplastic (e.g. thickened sewage sludge)
 Thixotropic (z. B. dispersion paint)
 Other:

Thickening method:

- Not thickened
 Static
 Mechanical by centrifuge / screening drum

Application of polymers:

- Yes
 No

Installation parts

Floor mounting (accessories set 6):

- A 276 Type 304 (1.4301)
 A 276 Type 316 Ti (1.4571)

Pump sump (accessories set 7):

- A 276 Type 304 (1.4301)
 A 276 Type 316 Ti (1.4571)

Tank (accessories set 22):

- A 276 Type 304 (1.4301)
 A 276 Type 316 Ti (1.4571)

Guide rail (accessories sets 7 and 22):

- A 276 Type 304 (1.4301)
 A 276 Type 316 Ti (1.4571)

Lifting equipment (crane)

Material:

- Galvanised steel
 A 276 Type 304 (1.4301)
 Aluminium

Aeration

Aeration method:

- None
Surface aeration:
 Brush aerator (e.g. Mammoth Rotor)
 Vertical shaft impeller

Subsurface aeration:

- Pipe diffusers
 Disc diffusers
 Plate diffusers
 Jet aerator

Air supply:

[scfm]	
[m³/h]	

Aerated area:

[ft²]	
[m²]	

Number of aerated zones:

n [quantity]	
-----------------	--

Tank/reservoir

Material:

- Concrete
- Steel
- Stainless steel
- Plastic
- Steel, enamelled

Coating:

--

Design:

- Covered
- Open

Tank geometry:

- Round
- Ring channel
- Square
- Rectangular
- Tank with circulating flow:

With curved deflector plates:

- Yes No

Tank with meandering flow:

With curved deflector plates:

- Yes No

Other:

Dimensions

Length:

[ft]	
[m]	

Width:

[ft]	
[m]	

Inside diameter:

D [ft]	
D [m]	

Fill level:

[ft]	
[m]	

Tank depth:

[ft]	
[m]	

Other:



KSB Aktiengesellschaft

P.O. Box 200743 • 06008 Halle (Saale) • Turmstraße 92 • 06110 Halle (Germany)

Tel. +49 345 4826-0 • Fax +49 345 4826-4699

www.ksb.com

03.11.2015

1592.551/09-EN