



# Sekamatik series

PREFABRICATED LIFTING STATIONS FOR RESIDENTIAL,  
COMMERCIAL OR INDUSTRIAL APPLICATIONS

# Wastewater is a demanding process, performance, day in day out. Xylem challenges, providing trusted service tradition of innovation in pumping

We've been able to create an optimized solution for domestic, commercial and industrial wastewater handling. Our stations are prefabricated and available in various sizes supplied complete with all the necessary equipment to allow ease and speed of installation.

Our customers include architects, builders merchants, civil contractors, consultants, distribution network, facility managers, house builders, local authorities, property developers, specifiers and many more.

## RESIDENTIAL BUILDINGS

*Apartments, cellars / basements, holiday lets, house extensions, outbuildings and refurbishments.*



### Consultants / Architects.

When specifying our packaged pumping stations we offer a full technical back-up, drawings, design guidelines and installation recommendations.

### Builders & Contractors.

Xylem offers a broad range of packaged pumping stations for various applications and requirements.

### Applications.

Collection and pressurization of sewage, grey water, rainwater coming from toilets, hand basins, showers, washing machines and bathrooms located in apartments, multi-family houses, office buildings, commercial malls etc.

### Pipework.

Domestic units come with a small bore discharge pipe where gravity flow is not possible.

requiring continuous  
Lowara solutions meet these  
in tough conditions. We have a long  
technology.



## COMMERCIAL BUILDINGS

*Airports, hotels, hospitals, offices, multi dwelling units, schools & universities, shopping centers, sports centers, tower blocks, train stations, warehouses or remote locations.*



## INDUSTRIAL APPLICATIONS

*Factories and Industrial Buildings.*



# Complete range overview

The Lowara Sekamatik series is a comprehensive range of wastewater lifting stations for the collection and pressurization of rain/clean/grey water and sewage for residential and commercial building applications.

Sekamatik lifting stations come all ready as complete units, as they include all necessary components such as tank, pumps, piping and the controls. All you need at once.

## Overview of models.



### **Sekamatik 10**

Ideal for secondary bathrooms/guest rooms

Tank volume up to 11 lt  
Max flow 15 m<sup>3</sup>/h  
Max head 17 m  
1 pump



### **Sekamatik 100**

Ideal for complete bathrooms

Tank volume up to 95 lt  
Max flow 50 m<sup>3</sup>/h  
Max head 15 m  
1 or 2 pumps



### **Sekamatik 200**

Ideal for secondary bathrooms/guest rooms

Tank volume 40 lt  
Max flow 22 m<sup>3</sup>/h  
Max head 14 m  
1 pump



### **Sekamatik 300**

Ideal for complete bathrooms

Tank volume up to 600 lt  
Max flow 60 m<sup>3</sup>/h  
Max head 18 m  
2 pumps



### **Sekamatik 50**

Ideal for complete bathrooms

Tank volume 46 lt  
Max flow 21 m<sup>3</sup>/h  
Max head 33 m  
1 or 2 pumps



### **Sekamatik 400/800**

Ideal for complete bathrooms

Tank volume up to 800 lt  
Max flow 200 m<sup>3</sup>/h  
Max head 38 m  
1 or 2 pumps

# The right solution for every application.

## Secondary bathrooms / guest bathrooms



	Sekamatik 10E 7M	Sekamatik 10E 15M	Sekamatik 10E 8M	Sekamatik 200
Residential sewage	•	•		
Residential sewage also from wall hung sanitary units		•		
Residential grey water	•	•	•	•
Residential grey water, also at high temperature		•		
Rainwater				•

## Complete bathrooms



	Sekamatik 50	Sekamatik 100	Sekamatik 300	Sekamatik 400/800
<ul style="list-style-type: none"> <li>Single-family houses</li> <li>Installations not requiring a backup pump</li> </ul>	• 1 pump	• 1 pump		
<ul style="list-style-type: none"> <li>2- and multi-family buildings</li> <li>Small commercial buildings (offices, small hotels, restaurants, etc.)</li> </ul>	• 2 pumps	• 2 pumps		
<ul style="list-style-type: none"> <li>Commercial buildings (offices, hotels, restaurants etc.)</li> </ul>			•	
<ul style="list-style-type: none"> <li>Multi-family buildings</li> <li>Large commercial buildings (shopping malls etc.)</li> </ul>				•

## Models



	Sekamatik 10	Sekamatik 200	Sekamatik 50	Sekamatik 100	Sekamatik 300	Sekamatik 400/800
# pumps -	1	1	1 or 2	1 or 2	2	1 or 2
Power (P <sub>2</sub> ) [kW]	0.35 - 1.1	0.18 - 1.1	0.9 - 1.9	1.1 - 2.1	1.7 - 3.3	0.9 - 11.5
Flow max [m <sup>3</sup> /h]	15	22	21	50	60	200
Head max [m]	17	14	33	15	18	38
Volume Total [lt.]	up to 11	40	46	up to 95	up to 600	up to 800
Delivery port	DN25 / 2"	1 1/4" F	2"	DN 80	DN 80	DN 100
Hydraulic	Open/Grinder	Open	Grinder	Vortex	Vortex	Channel/Vortex

# Sekamatik 10E 7M

## COMPACT WASTEWATER DISPOSAL UNIT WITH GRINDER PUMP

### Overview.

The Sekamatik 10E 7M is a compact lifting station for removal of wastewater from WCs, showers, hand basins, urinals and bidets in basements, apartments or cellars which are below the sewer backflow level. The Sekamatik 10E 7M is also suitable for installation of sanitary facilities according to DIN EN 12050-3. It has a built-in pump with powerful stainless steel grinder system for solids. The DN 25 discharge pipe can be easily installed with minimum construction work. The WC inlet allows installation directly behind the WC, where minimal space is available. The tank design with separate dry area allows easy access if servicing is required.

**DIN EN 12050-3:** Conformity and design approved and controlled by LGA.

**Pumped liquid:** Domestic sewage and grey water.

**Operation:** Intermittent.

### Specifications.

Compact wastewater disposal unit comprising:

**Collection Tank:** Odour-tight plastic collection tank with separate dry area.

Maximum utility volume 11 liters. WC-inlet DN 100 horizontal, inlet height 180 mm (DIN 1387 Form A / DIN 1388 Form A). Two inlets DN 40 with integrated non-return valve and sealing ring, discharge DN 25 with integrated ball backflow preventer. Air vent with activated carbon filter.

**Pump:** Single-stage centrifugal stainless steel pump with horizontal discharge. Open multi-channel impeller with stainless steel cutting system.

**Motor:** Single-phase electric motor with thermal sensors embedded in the winding. Insulation Class B. Stainless steel rotor shaft, pre-lubricated bearings.

**Shaft Seals:** Triple lip-seals.

**Control:** Pneumatic level control with control electronics. Seal monitoring, alarm signal and runtime monitoring.

### Materials.

Collection tank	Composite
Pump housing	Glass fibre reinforced composite
Impeller	Glass fibre reinforced composite
Motor housing, rotor shaft	Stainless steel 1.4301
	Stainless steel 1.4021
Cutting system	Stainless steel 1.4122

### Technical Data.

Motor input $P_1$	650 W
Motor output $P_2$	300 W
Voltage	230V-240V/1Ph 50Hz
Speed	2900 rpm
Nominal current	2,6 A
Cable	H 03VV-F3x0,75
Insulation class (complete unit)	IP 44
Weight	8 kg
Discharge	DN 25 (o.d. 28-34 mm)

### Equipment supplied.

Tank with pump, with ball backflow preventer, flexible connection piece and terminal clamp, 1,4 m of cable with plug, non-return valves.



## Performance.

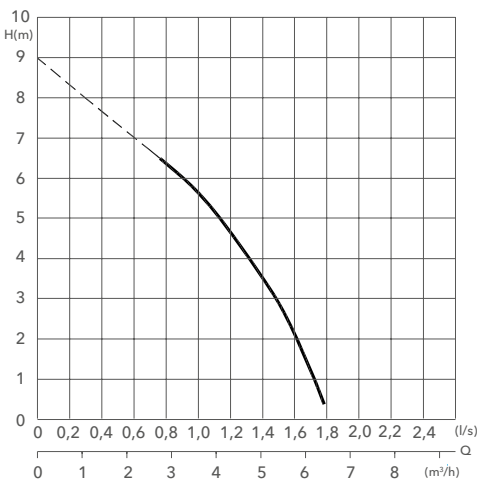

## Installation.

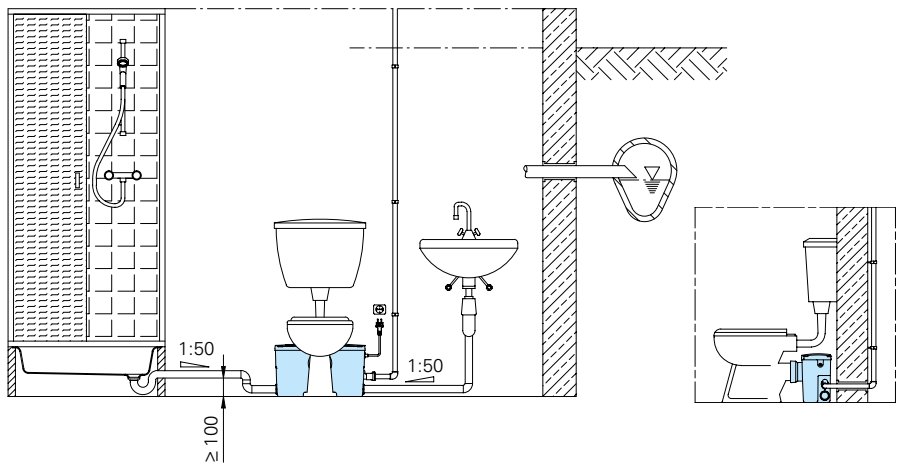

## Dimensions.

(all dimensions are in mm.)

1. Tank cover (screwed)
2. Air vent with activated carbon filter
3. Connection for inlet DN 40 (Ø 40)
4. Connection for DN 25 discharge pipe with integrated ball backflow preventer
5. Cable inlet
6. Connection for WC inlet, DIN1387, Form A, DIN1388, Form A

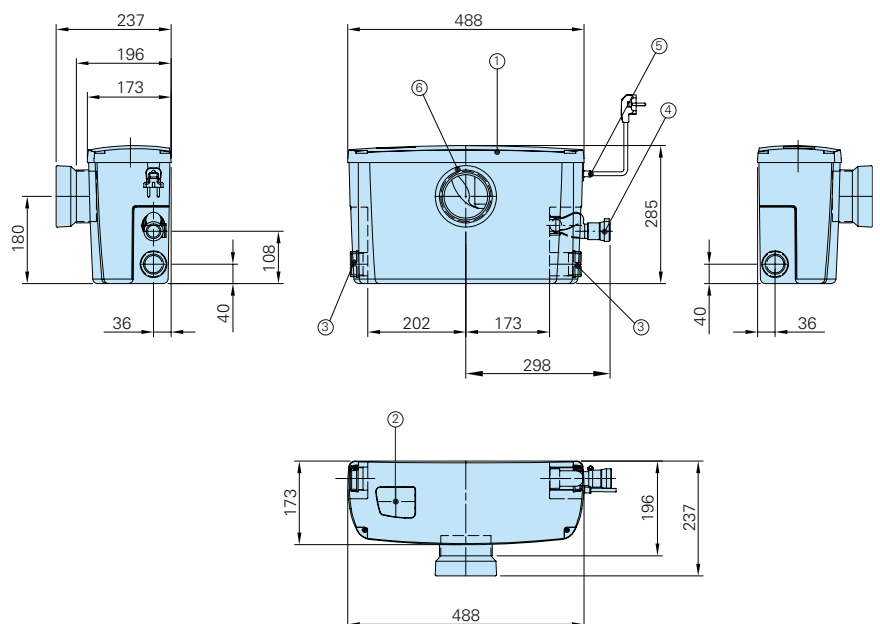

# Sekamatik 10E 15M

## COMPACT SEWAGE DISPOSAL UNIT WITH GRINDER SYSTEM

### Overview.

The Sekamatik 10E 15M disposal unit is designed to remove wastewater from WCs, hand basins, washing machines and showers in basements, apartments or cellars which are below the sewer backflow level and require the installation of a lifting station. It has the advantage of a ground level direct WC connection, enabling the Sekamatik 10E 15M to be installed directly on to the back of the toilet. It incorporates a reliable stainless steel grinder system for solids.

The diameter for the discharge pipe should be 1¼" minimum, which can be easily laid at low cost with a minimum construction work.

**DIN EN 12050-1:** Conformity and design approved and controlled by LGA.

**Pumped liquid:** Drainage water, wastewater or sewage. Max. liquid temperature: 35°C, short term up to 60°C.

**Operation:** Intermittent.

### Specifications.

Compact sewage disposal unit consisting of:

**Collecting tank:** Odour and gas-tight composite collection tank. Max. utility volume 11 liters. WC-inlet: DN 100 horizontal, inlet height 180 mm. Vertical inlet DN 50 on the top of the tank. Air vent DN 25 vertical. Cleaning cover with screw cap.

**Pump:** Single stage centrifugal pump with horizontal discharge. Open multi-channel impeller with cutting system. Discharge: BSP 2" M.

**Motor:** Single phase electric motor with thermal sensors embedded in the winding. Insulation class H. Degree of protection IP 68.

**Shaft/Bearing:** Large diameter steel rotor shaft, pre-lubricated bearings.

**Seals:** Combination of mechanical seals (silicon carbide / silicon carbide) and lip seal with oil chamber.

**Controls:** Pneumatic level control with pressure switch. Electronic control box.

Overload protection. Temperature control of the winding with automatic motor restart.

### Materials.

Collection tank	Composite
Pump housing,	Cast iron
motor housing, impeller	GG 25/EN-GJL-250
Cutting system	Stainless steel 1.4528
Rotor shaft, screws	Stainless steel
Seal kit	NBR

### Technical Data.

Motor input P <sub>1</sub>	1,5 kW
Motor output P <sub>2</sub>	1,1 kW
Voltage	230 V/1 Ph, 50 Hz
Speed	2900 rpm
Nominal current	7,0 A
Cable	H 07RN-F 4G1,5
Weight	32 kg
Discharge	BSP 2" M

### Equipment supplied.

Tank with pump, pneumatic electronic control box, 2 m of cable and plug.





### Performance.

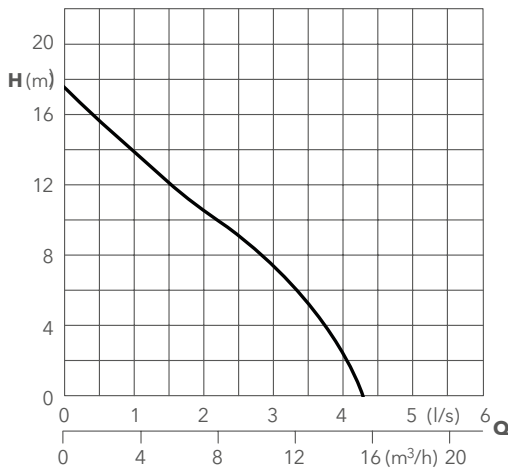

### Installation.

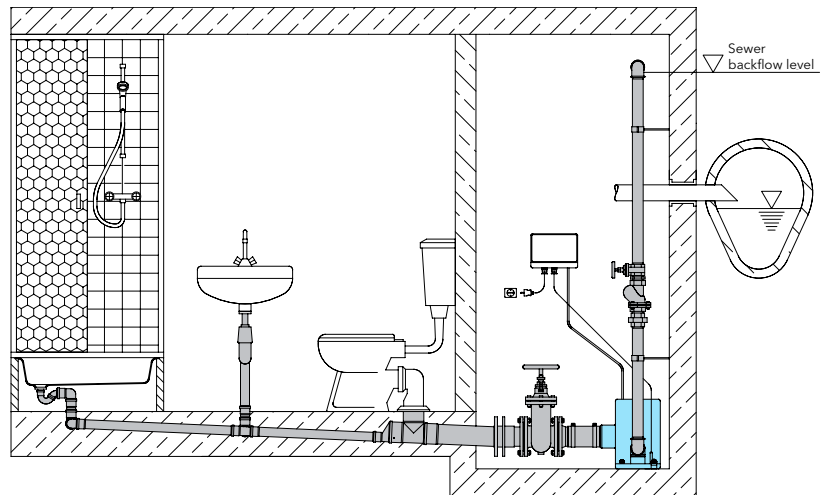

### Dimensions.

(all dimensions are in mm.)

1. Inlet DN 100
2. WC-direct connection
3. Connection for discharge pipe BSP 2" M
4. Cable inlet
5. Cleaning cover
6. Connection for pneumatic level control
7. Inlet DN50
8. Air vent cap with PVC tube
9. Pump cover
10. Knurled screws
11. Tank fixing point

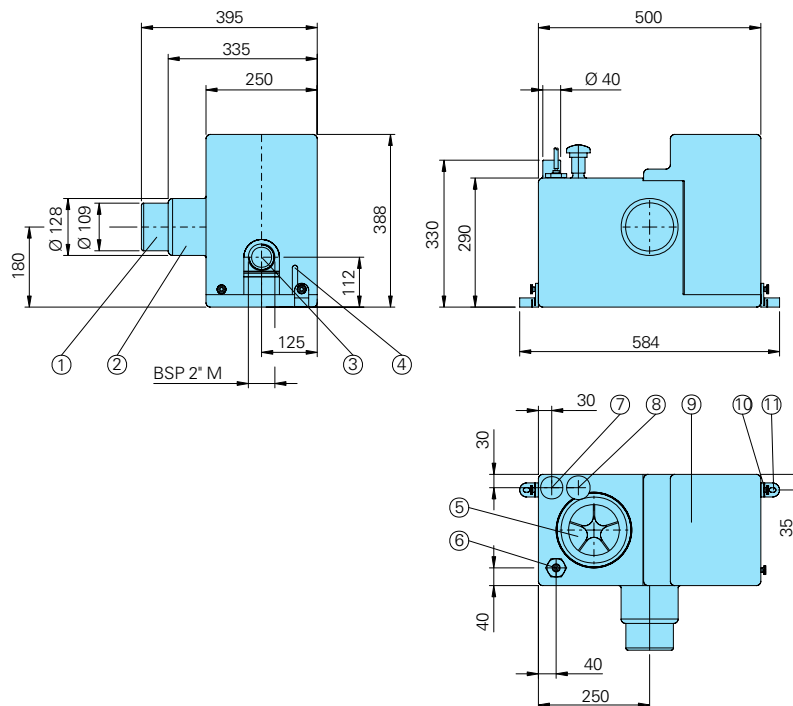

# Sekamatik 10E 8M

## COMPACT DRAINAGE WATER AND EFFLUENT DISPOSAL UNIT WITH STAINLESS STEEL SUBMERSIBLE PUMP

### Overview.

The Sekamatik 10E 8M compact mini pump station is designed to remove wastewater from hand basins, washing machines, urinals, bidets, showers, bathtubs and dishwashers in basements, apartments or cellars which are below the sewer backflow level. The Sekamatik 10E 8M is also suitable for installation of sanitary facilities according to DIN EN 12050-3. The built-in stainless steel drainage pump operates automatically by a float switch control.

The DN 25 discharge can be easily installed with minimum construction work.

The Sekamatik 10E 8M compact design allows installation directly under the hand basin, where space is at a premium.

The new tank design with separate dry area allows easy access if servicing is required.

**DIN EN 12050-3:** Conformity and design approved and controlled by LGA.

**Pumped liquid:** Domestic drainage water and effluent.

**Operation:** Intermittent.

### Specifications.

Compact domestic effluent disposal unit comprising:

**Collection Tank:** Odour-tight plastic collection tank with separate dry area. Maximum utility volume 11 liters.

One top inlet DN 40. Two lateral inlets DN 40 with integrated non-return valve and sealing ring. DN 25 discharge diameter with integrated ball backflow preventer. Air vent with activated carbon filter.

**Pump:** Single-stage centrifugal stainless steel pump with horizontal discharge.

**Motor:** Single-phase electric motor with thermal sensors embedded in the winding. Insulation Class B. Stainless steel rotor shaft, pre-lubricated bearings.

**Shaft Seals:** Triple lip-seals.

**Controls:** Pneumatic level control with control electronics. Seal monitoring, alarm signal and runtime monitoring.

### Materials.

Collection tank	Composite
Pump housing	Glass fibre reinforced composite
Impeller	Glass fibre reinforced composite
Motor housing,	Stainless steel
	1.4301
Rotor shaft	1.4021

### Technical Data.

Motor input $P_1$	650 W
Motor output $P_2$	350W
Voltage	230V-240V/1Ph 50Hz
Speed	2900 rpm
Nominal current	2,6 A
Cable	H 03VV-F3x0,75
Insulation Class	IP 44
(complete appliance)	
Weight	8 kg
Discharge	DN 25
	(o.d. 28-34 mm)

### Equipment supplied.

Tank with pump, with ball backflow preventer, flexible connection piece and terminal clamp, 1,4 m of cable with plug, non-return valves.



### Performance.

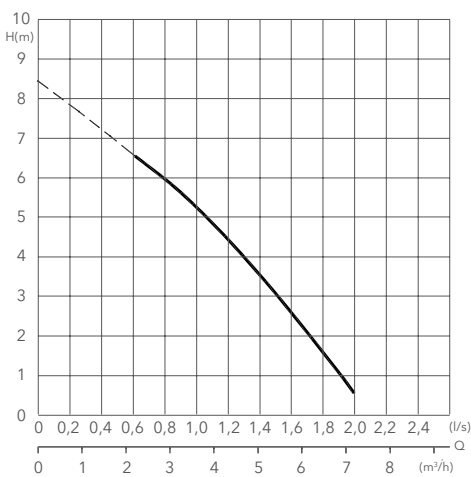

### Installation.

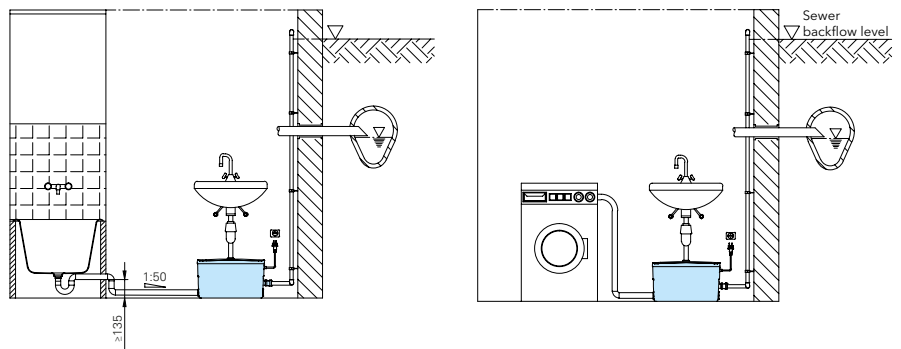

### Dimensions.

(all dimensions are in mm.)

1. Tank cover
2. Air vent with activated carbon filter
3. Connection for inlet DN 40 (Ø40)
4. Connection for DN 25 discharge pipe with integrated ball backflow preventer
5. Cable inlet
6. Connection for hand basin DN 40 (Ø40)

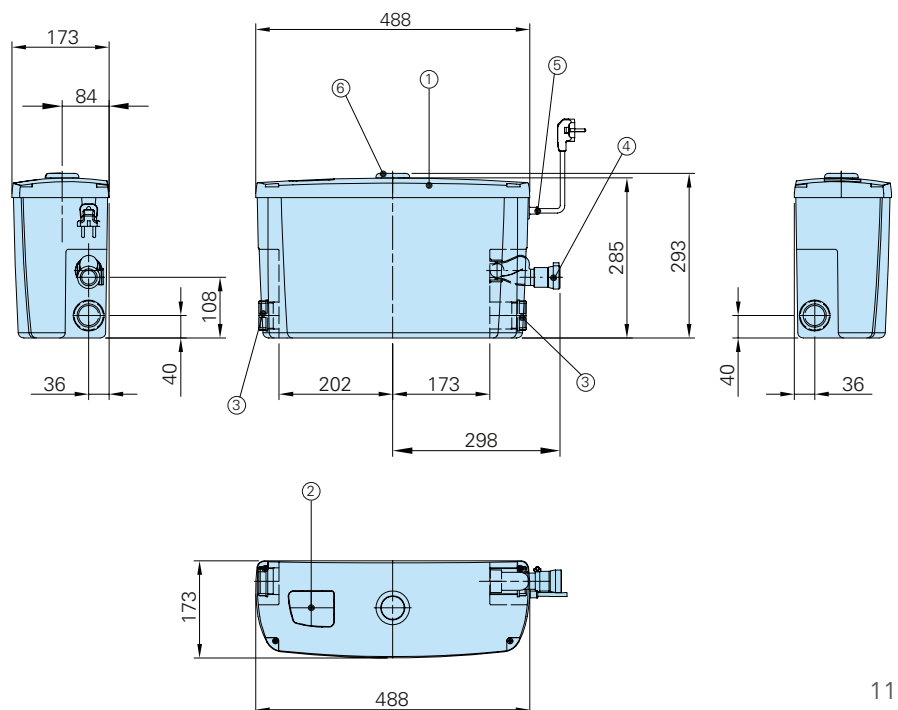

# Sekamatik 200

## DOMESTIC WASTEWATER DISPOSAL UNIT WITH UNDER-FLOOR COLLECTING TANK

### Overview.

The Sekamatik 200 disposal unit removes wastewater from hand basins, washing machines, showers or baths, and de-waters cellars, basements and garages.

**DIN EN 12050-3:** Conformity and design approved and controlled by LGA.

**Installation:** Collecting tank for under-floor installation with adjustable access cover.

**Pumped liquid:** Clear water and drainage water. Max. liquid temperature: 35°C, short term up to 60°C.

### Specifications.

Wastewater disposal for under-floor installation consisting of:

**Collecting tank:** Plastic tank fixed to prevent lifting, 40 liters volume, with 3 inlets DN 100.

Connecting piece DN 70 for air vent and cable duct. Frame with adjustable height to adapt the cover plate to the floor level. Odour tight cover plate with floor drain. The cover plate can be used as a gutter or a tile frame. Both frame and plate are adjustable in height and capable of being turned through 360° for adjustment to the floor level and direction of tiles after the tiles have been laid.

**Installation kit:** Discharge connector and pipe for the pump are fitted in the tank, including a non-return valve in the pipework (only for the pump models without an integrated non return-valve).

**Pump/Motor:** Single stage centrifugal submersible drainage pumps with float switch control for automatic operation depending on liquid level in the tank. Models 200 E UF 3M K2 - 200 E UF 12M K4 with integrated non-return valve. Fully submersible, pressure-tight electric motor, jacket cooled. Insulation class F. Degree of protection IP 68.

### Materials.

Collecting tank	Polyethylene
Installation kit	PVC
Pump housing	Composite (200 E UF 3M K2 - 200 E UF 12M K4) Stainless steel (200 E UF 12M K7 - 200 E UF 15M K8)
Motor housing	Stainless steel
Impeller	Composite (200 E UF 3M K2 - 200 E UF 12M K4) Stainless steel (200 E UF 12M K7 - 200 E UF 15M K8)
Rotor shaft, screws	Stainless steel
Seal kit	NBR

### Technical Data.

Curve Pump type No.	Motor input P <sub>1</sub> (kW)	Motor output P <sub>2</sub> (kW)	Nominal current (A)	Discharge	Weight (kg)
① 200 E UF 3M K2	0,35	0,18	1,8	BSP 11/4"	4,6
② 200 E UF 10M K3	1,00	0,76	4,5	BSP 11/4"	8,0
③ 200 E UF 12M K4	1,20	0,91	5,0	BSP 11/4"	8,3
④ 200 E UF 12M K7	1,20	0,80	5,0	BSP 11/4"	9,0
⑤ 200 E UF 15M K8	1,50	1,10	6,9	BSP 11/4"	11,0



### Performance.

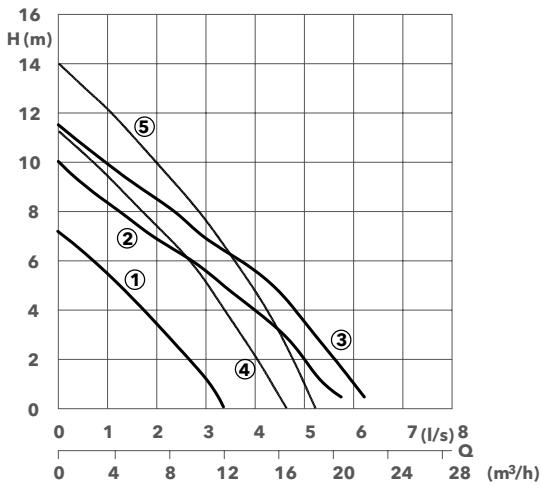

### Installation.

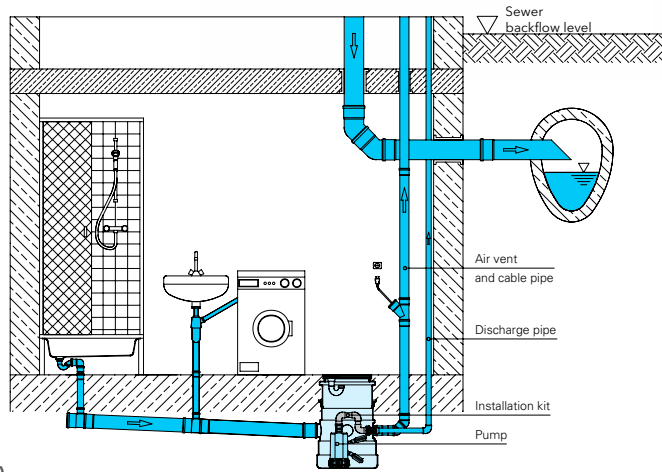

### Dimensions.

(all dimensions are in mm.)

Collecting tank

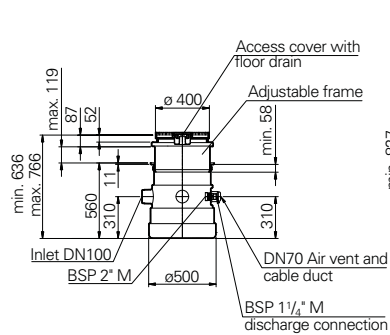

Collecting tank with extension kit

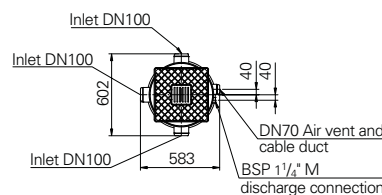
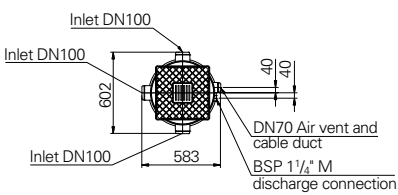
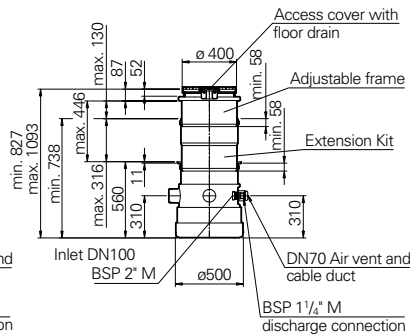



# Sekamatik 50E (single pump)

# Sekamatik 50D (twin pump)

## COMPACT SEWAGE DISPOSAL UNIT WITH SUBMERSIBLE WASTEWATER PUMPS WITH GRINDER SYSTEM

### Overview.

The Sekamatik 50E and Sekamatik 50D are versatile compact sewage disposal units suitable for removing dirty water and effluent where gravity drainage is not possible. They are used for pumping sewage and wastewater from toilets, hand basins, showers and rooms which are below the sewer level (see DIN EN 12056), or where small discharge pipes are necessary such as under difficult topographic conditions or areas of low population.

With the advantage of using discharge pipes of either DN 40 or DN 50 diameters, reduced construction work and cost is possible compared to conventional discharge pipes. They are available as a single pump station (Sekamatik 50E) or as a twin pump station (Sekamatik 50D).

**DIN EN 12050-3:** Conformity and design approved and controlled by LGA.

**Pumped liquid:** Wastewater or sewage containing soft solids. Max. liquid temperature: 35°C short term up to 60°C.

**Operation:** Intermittent.

### Specifications.

Flood protected single or twin pump lifting station consisting of:

**Collecting tank:** Odour and gas-tight plastic collecting tank.

**Inlets:**

- Horizontal: DN 100/DN 50 (180 mm or 250 mm height).
- Vertical: DN 100/DN 50.

Air vent union: DN 70 vertical. Connection for diaphragm pump: BSP 1" F. Cleaning cover with screw cap.

**Pump:** Single stage centrifugal pump with horizontal discharge. Open multi-channel impeller with grinder system.

Sekamatik 50D with 2 pumps. Discharge: BSP 2" M.

**Motor:** Fully submersible, pressure-tight electric motor, 1 phase or 3 phase. Thermal sensors embedded in the winding. Insulation class F. Degree of protection IP 68.

**Shaft/Bearings:** Large diameter stainless steel rotor shaft, pre-lubricated bearings.

**Seals:** Models 15M and 13T with combination of mechanical seal (silicon carbide) and lip seal with oil chamber.

Model 25T with 2 mechanical seals (silicon-carbide) with oil chamber. Oil inspection from outside.

SEKAMATIK 50 E



SEKAMATIK 50 D



### Materials.

Collecting tank	Composite
Pump housing, impeller, motor housing	Cast iron
Grinder system	GG25/EN-GJL-250
Rotor shaft, screws	Stainless steel
Seal kit	NBR

### Performance.

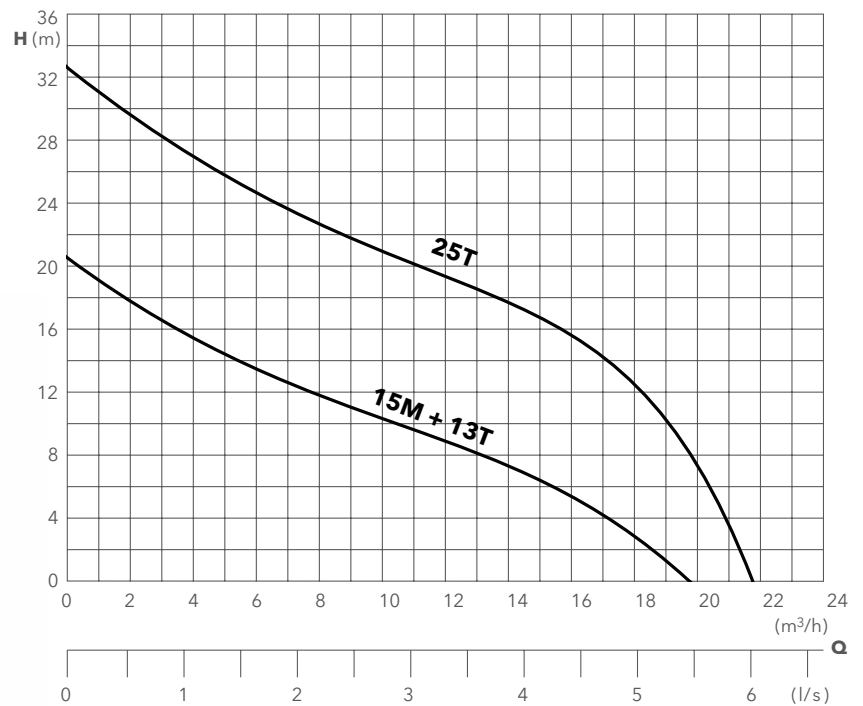

## Technical Data.

Type	Motor input P <sub>1</sub> (kW)	Motor output P <sub>2</sub> (kW)	Voltage 50 Hz (V)	Speed (rpm)	Nominal current (A)	Weight (kg)
<b>Sekamatik 50E</b>						
50 E 15M H1*	1,5	1,1	230-240/1Ph	2900	7,5	37
50 E 15M H2*						
50 E 13T H1*	1,3	0,9	400-415/3Ph	2900	2,5	37
50 E 13T H2*						
50 E 25T H1*	2,5	1,9	400-415/3Ph	2900	4,4	51
50 E 25T H2*						
<b>Sekamatik 50D</b>						
50 D 15M H1*	1,5	1,1	230-240/1Ph	2900	7,5	62
50 D 15M H2*						
50 D 13T H1*	1,3	0,9	400-415/3Ph	2900	2,5	62
50 D 13T H2*						
50 D 25T H1*	2,5	1,9	400-415/3Ph	2900	4,4	89
50 D 25T H2*						

\* Height to main horizontal inlet in mm  
 H1 = 180 mm  
 H2 = 250 mm

Performance data for each pump

Collecting tank	Sekamatik 50E		Sekamatik 50D	
Inlets height	180 mm	250 mm	180 mm	250 mm
Total volume	46 liters	46 liters	46 liters	46 liters
Operating volume	31 liters	31 liters	31 liters	31 liters

**Inlets:** DN 100, DN 50 (2 x)

**Discharge:** BSP2" M

**Air vent:** DN 70

**Connection for diaphragm pump:** BSP 1" F

**Cable**

Unit-control box

Control box plug

**Type**

H07RN-F7G1,5

H07RN-F5G 1,5

**Length**

3 m

0,8 m

## Controls.

Pneumatic level control with pressure control.  
 Electronic control box for control, monitoring and notification of all important functions with advice of any problems.

Motor protection with temperature control of the winding. Optical indication of unit failure.

Alarm signal through integral buzzer.

Volt-free contact for remote signal. Control

indication for direction of rotation. Motor

overrun period which prevents sewage

build up and blockage. Easy conversion to

mains independent alarm via 9,0 V battery

installation. Additionally for twin pump

station Sekamatik 50D: Auto-change over

after each pump cycle. Operation of second

pump at high flow. In the event of failure one

pump automatically changes to the second

pump.

## Equipment supplied.

Tank with 1 pump (Sekamatik 50E) or 2 pumps (Sekamatik 50D). Discharge with 90° elbow BSP 2" M. Elastic union piece for inlet DN 100 and air vent DN 70 with bands.

Pneumatic level control.

Electronic control box with cable and plug.

## Dimensions. (all dimensions are in mm.)

### Sekamatik 50 E/D 15 M/13T

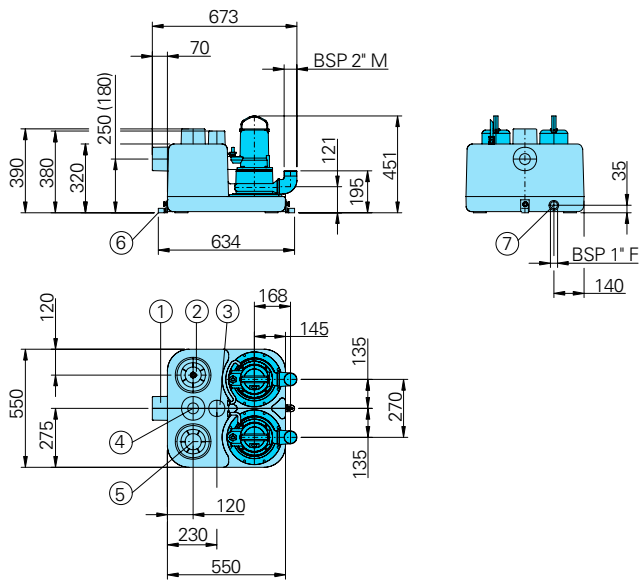

### Sekamatik 50 E/D 15 M/25T

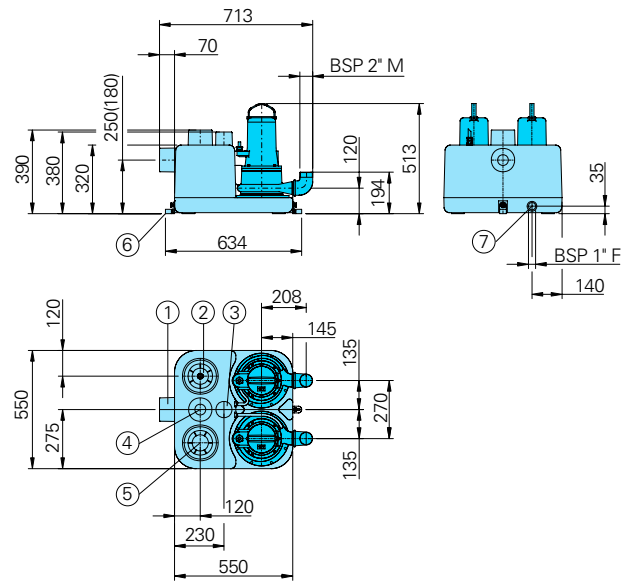

## Dimensions. (all dimensions are in mm.)

1. Horizontal inlet DN 100/DN 50
2. Connection for Pneumatic level control
3. Air vent DN 70
4. Vertical inlet DN 100/DN 50
5. Cleaning cover
6. Tank fixing point
7. Connection for diaphragm pump

## Installation.

Main inlet horizontal

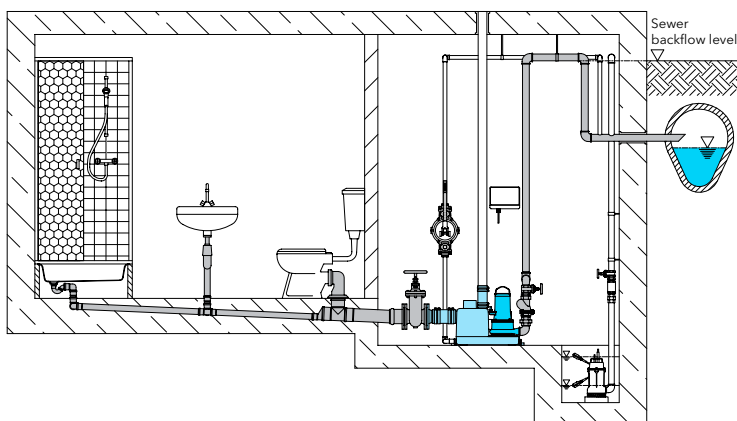

Direct connection  
Euro-WC  
(Inlet height 180 mm)

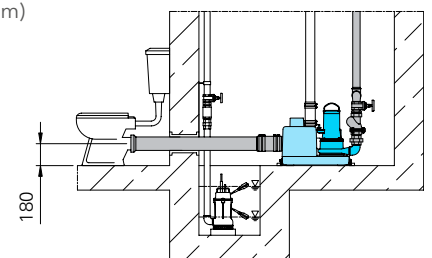

Direct connection  
Wall hung WC  
(Inlet height 250 mm)

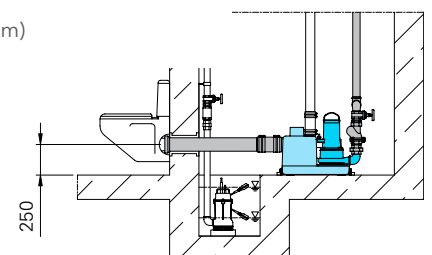

# Sekamatik 100E S

## COMPACT SEWAGE DISPOSAL UNIT WITH INTEGRATED SWING CHECK VALVE

### Overview.

The Sekamatik 100E S is a compact sewage disposal unit suitable for pumping sewage and wastewater from toilets, hand basins, showers and rooms which are below the sewer level according to DIN 1986.

Sekamatik 100E S will prevent back up and flooding where there is a natural fall but the sewer is flooded or unable to drain. Sekamatik 100E S is the ideal solution for new builds or renovation of old buildings.

### Applications.

Collection and pressurization of sewage and wastewater from:

- basement rooms.
- sanitary facilities in cellar rooms.
- sanitary facilities in restaurants, hotels, cinemas, theatres, shopping malls, schools and hospitals.

**DIN EN 12050-3:** Conformity and design approved and controlled by LGA.

**Pumped liquid:** Clear water or drainage water, wastewater or sewage containing soft solids.

Max. liquid temperature: 35°C, short term up to 60°C.

**Operation:** Intermittent.

### Construction.

Flood protected single pump lifting station consisting of:

**Collecting tank:** Odour and gas tight plastic collecting tank.

**Inlets:**

- Horizontal: DN 100, 180 mm height.
- Horizontal: DN 100, 250 mm height.
- Vertical: DN 100.
- Horizontal and Vertical: DN 150.
- Vertical: DN 40.

**Discharge:** Flange DN 80. Flexible union piece DN 80/Ø 89. With integrated soft check valve.

Air vent: DN 70 vertical. Connection for diaphragm pump: BSP 1" F. Cleaning cover with screw cap.

**Pump:** Pump chamber integrated in the collecting tank. Non clogging impeller, spherical clearance 40 mm.

**Motor:** Fully submersible, pressure tight electric motor, 1Ph or 3Ph. Thermal sensors embedded in the winding.

Insulation class F. Degree of protection IP 68. Stainless steel rotor shaft, pre-lubricated bearings.

**Cable:**

Pump, 3 m:

Model M: H07RN-F5G1,5

Model T: H07RN-F6G1

Control box plug, 0,8 m:

Model M: H07RN-F3G1,5 (plug 230 V)

Model T: H07RN-F5G1,5 (CEE-plug 16 A / 400 V)

**Seals:** Triple lip seal combination in separate oil chamber. Oil inspection from outside.





## Materials.

Collecting Tank	Polyethylene
Impeller	Cast steel
Pump flange,	Glass-fibre, reinforced
Motor housing cover	synthetic material (composite)
Pressure cover	Cast iron
non-return valve	
Non-return valve	Composite
housing	
Motor housing	Stainless steel
Rotor shaft	Stainless steel
Mechanical connection	
parts	Stainless steel
Seal kit	NBR

## Performance.

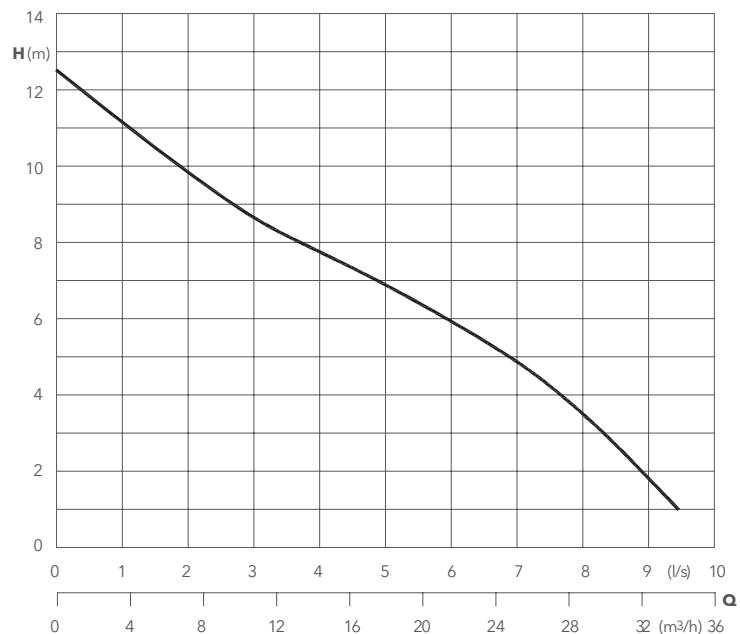

## Technical Data.

Curve Pump type No.	Motor input P <sub>1</sub> (kW)	Motor output P <sub>2</sub> (kW)	Voltage (V)	Nominal current (A)	Collection tank		Weight (kg)
					Total volume	Operation volume	
Sekamatik 100 E S16M	1,6	1,2	230/1Ph	7,0	70 l	30 l	33,0
Sekamatik 100 E S15T	1,5	1,2	400/3Ph	2,5	70 l	30 l	33,0

Speed: 2900 rpm

## Controls.

Pneumatic level control with pressure operation. Motor over run period which prevents sewage build up and blockage. Electronic control box for control and monitoring of all important functions. Motor protection with temperature control of the winding. Optical failure alarm. Acoustic alarm by buzzer. Volt free contact for remote signal. Control indication for direction of rotation.

## Equipment supplied.

Tank with 1 pump, discharge with DN 80 soft check valve and flanged elastic union piece DN 80/Ø89 with hose bands, gasket and screws. Elastic union piece for inlet DN 100 and air vent DN 70 with hose bands. Fixing bolts for tank fixing point. Pneumatic level control. Electronic control box with cable.

## Dimensions.

(all dimensions are in mm.)

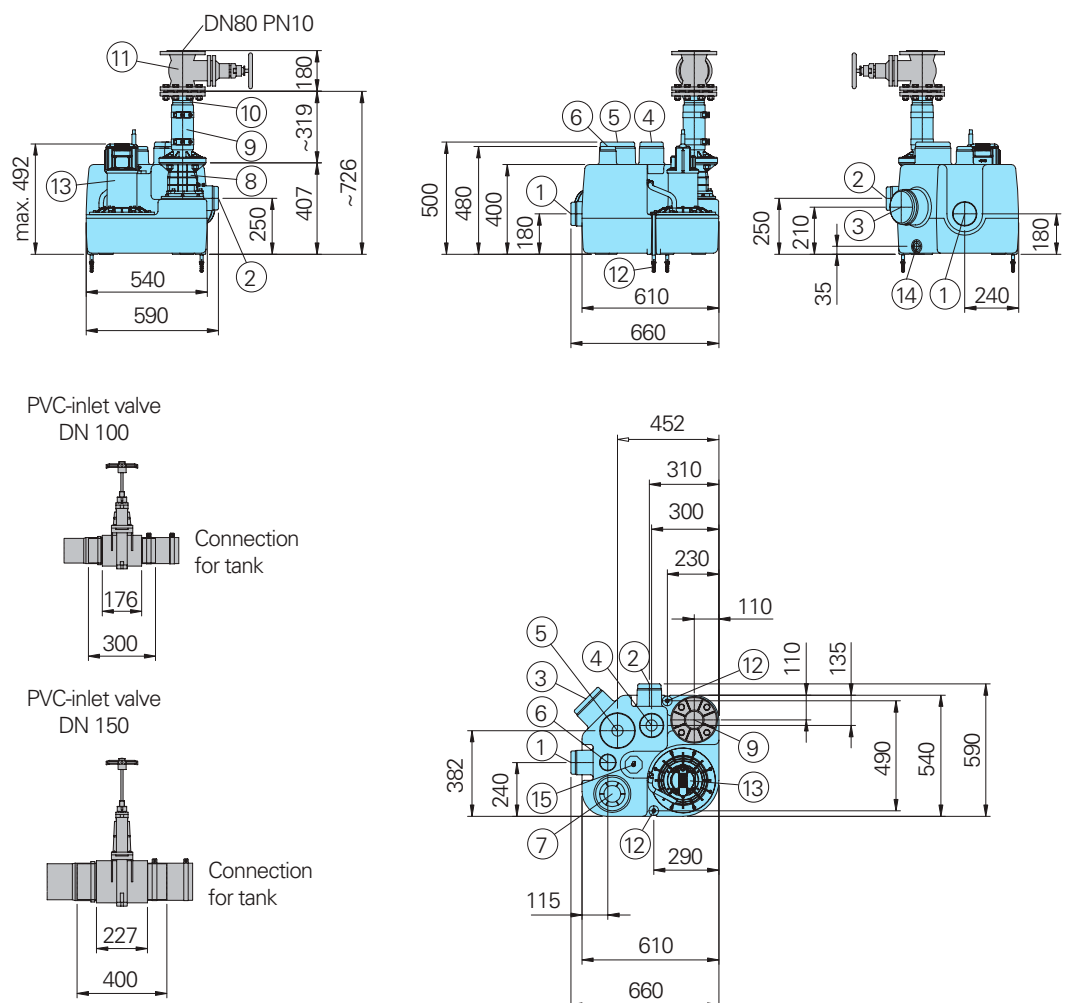

# Installation.

Main inlet vertical

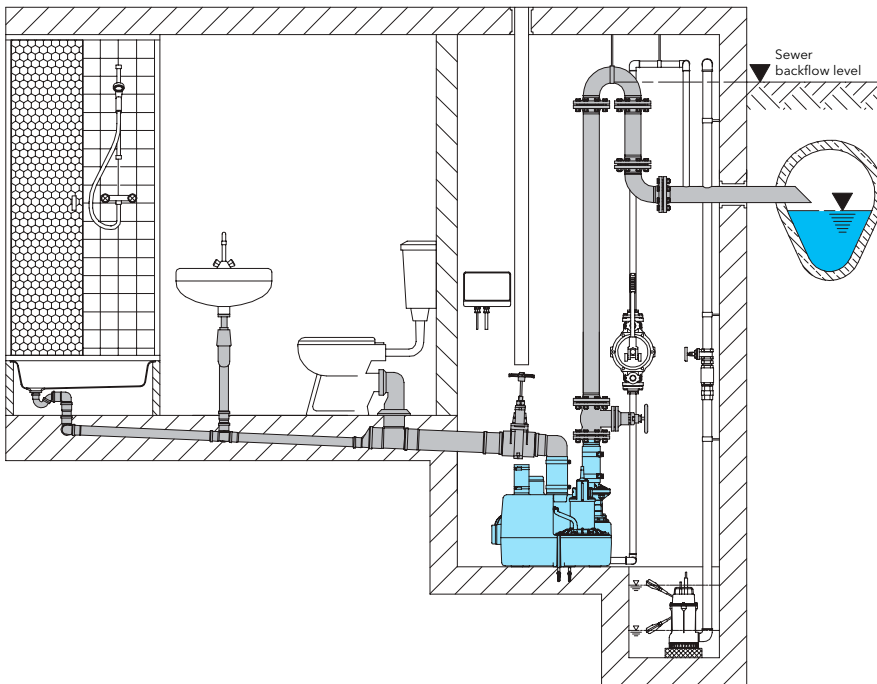

Direct connection Euro WC  
(Inlet height 180 mm)

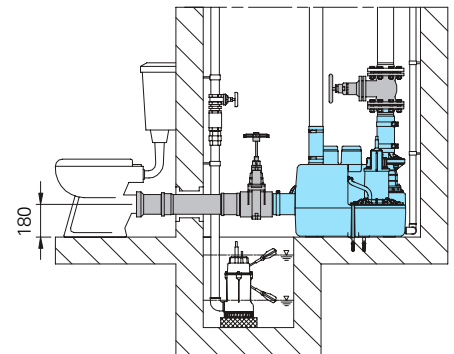

Direct connection Wall hung WC  
(Inlet height 250 mm)

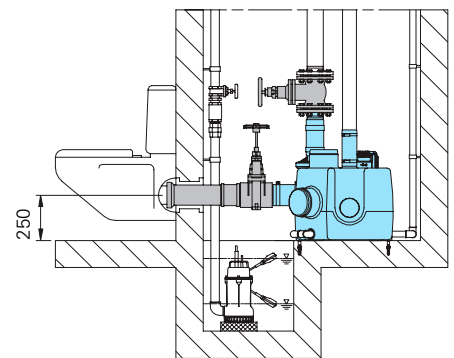

## Dimensions. (all dimensions are in mm.)

1. Horizontal inlet DN 100
2. Horizontal inlet DN 100
3. Horizontal inlet DN 150
4. Vertical inlet DN 100/40
5. Vertical inlet DN 150/40
6. Air vent DN 70
7. Cleaning cover
8. Soft ball check valve DN 80
9. Elastic union piece  
(Connection for discharge)
10. Flanged spigot DN 80/Ø89
11. Flanged gate valve
12. Tank fixing point
13. Pump
14. Connection for diaphragm pump BSP1"
15. Connection for pneumatic control box

# Sekamatik 100

## COMPACT SEWAGE DISPOSAL UNIT WITH INTEGRATED SWING CHECK VALVE.

### Overview.

The Sekamatik 100 is a compact sewage disposal unit suitable for pumping sewage and wastewater from toilets, hand basins, showers and rooms which are below the sewer level. Sekamatik 100 will prevent back up and flooding where there is a natural fall but the sewer is flooded or unable to drain. Sekamatik 100 is the ideal solution for new construction or renovation of old buildings.

Sekamatik 100 is used for applications in:

- basement rooms.
- sanitary facilities in cellar rooms.
- sanitary facilities in restaurants, hotels, cinemas, theatres, shopping malls, schools and hospitals.

**DIN EN 12050-1:** Conformity and design approved and controlled by LGA.

**Pumped liquid:** Clear water or drainage water, wastewater or sewage containing soft solids. Max. liquid temperature: 35°C, short term up to 60°C.

**Operation:** Intermittent.

### Construction.

Flood protected single or twin pump lifting station consisting of:

**Collecting tank:** Odour and gas tight plastic collecting tank.

**Inlets:**

- Horizontal: DN 100, 180 mm height.
- Horizontal: DN 100, 250 mm height.
- Vertical: DN 100.
- Horizontal and Vertical: DN 150.
- Vertical: DN 40.

**Discharge:** Flange DN 80. Flexible union piece DN 80/DN 100. With integrated soft ball check valve.

Air vent: DN 70 vertical. Connection for diaphragm pump: BSP 1" F. Cleaning cover with screw cap.

**Pump:** Pump chamber integrated in the collecting tank. Vortex impeller, spherical clearance 45 mm.

**Motor:** Fully submersible, pressure-tight electric motor, 1Ph or 3Ph. Thermal sensors embedded in the winding.

Insulation class F. Degree of protection IP 68. Stainless steel rotor shaft, pre lubricated bearings.

**Seals:** Triple lip seal combination in separate oil chamber. Oil inspection from outside.



## Materials.

Collecting tank with pump housing	Polyethylene
Impeller, pump flange	Cast iron
	GG 25/EN-GJL-250
Rotor shaft, screws	Stainless steel
Seal kit	NBR

## Performance.

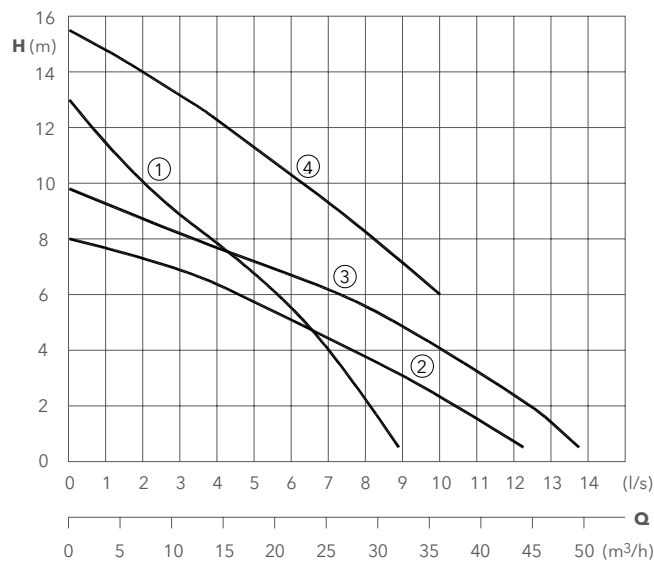

## Technical Data.

Curve No.	Type	No. of Pumps	Motor input P <sub>1</sub> (kW)	Motor output P <sub>2</sub> (kW)	Voltage 50 Hz (V)	Speed (rpm)	Nominal current (A)	Weight (kg)	Collection tank Total volume	Operating volume
①	<b>Sekamatik 100 E 16M</b>	1	1,6	1,1	230/1Ph	2900	7,0	64	70 l	30 l
①	<b>100 E 15TA</b>	1	1,5	1,1	400/3Ph	2900	2,5	64	70 l	30 l
②	<b>100 E 17M</b>	1	1,7	1,3	230/1Ph	1450	7,1	66	70 l	30 l
②	<b>100 E 15T</b>	1	1,5	1,1	400/3Ph	1450	3,1	66	70 l	30 l
③	<b>100 E 23M</b>	1	2,3	1,7	230/1Ph	1450	10,7	73	70 l	30 l
③	<b>100 E 23T</b>	1	2,3	1,7	400/3Ph	1450	4,4	73	70 l	30 l
④	<b>100 E 30T</b>	1	3,0	2,1	400/3Ph	2900	5,1	73	70 l	30 l
①	<b>Sekamatik 100 D 16M</b>	2	1,6	1,1	230/1Ph	2900	7,0	92	95 l	45 l
①	<b>100 D 15TA</b>	2	1,5	1,1	400/3Ph	2900	2,5	92	95 l	45 l
②	<b>100 D 17M</b>	2	1,7	1,3	230/1Ph	1450	7,1	96	95 l	45 l
②	<b>100 D 15T</b>	2	1,5	1,1	400/3Ph	1450	3,1	96	95 l	45 l
③	<b>100 D 23M</b>	2	2,3	1,7	230/1Ph	1450	10,7	110	95 l	45 l
③	<b>100 D 23T</b>	2	2,3	1,7	400/3Ph	1450	4,4	110	95 l	45 l
④	<b>100 D 30T</b>	2	3,0	2,1	400/3Ph	2900	5,1	110	95 l	45 l

The types Sekamatik 100 D 17M to 100 D 30T are also available with 1 pump to allow a later installation of the second pump.

**Inlets:** DN 100 (3 x), DN 150 (2 x), DN 40

**Discharge:** Flange DN 80. EU piece DN 80/ DN100

**Air vent:** DN 70

**Connection for diaphragm pump:** BSP 1" F

Cable	Type	Length
Unit-control box	H07 RN-F7G 1,5	3 m
Control box-plug	H07 RN-F5G 1,5	0,8 m



## Controls.

Pneumatic level control with pressure operation. Motor over run period which prevents sewage build up and blockage. Electronic control box for control and monitoring of all important functions. Motor protection with temperature control of the winding. Optical failure alarm. Acoustic alarm by buzzer. Volt free contact for remote signal.

Control indication for direction of rotation.

Additional for twin pump station:

Auto-change over after each pump cycle. Operation of both pumps at high flow. In the event of failure automatic change over to the second pump.

## Equipment supplied.

Tank with 1 pump (Sekamatik 100 E) or 2 pumps (Sekamatik 100 D), discharge with DN 80 soft ball check valve and flanged elastic union piece DN 80/DN 100 with hose bands. Elastic union piece for inlet DN 100 and air vent DN 70 with hose bands. Pneumatic level control. Electronic control box with cable.

## Dimensions.

(all dimensions are in mm.)

Sekamatik 100 E

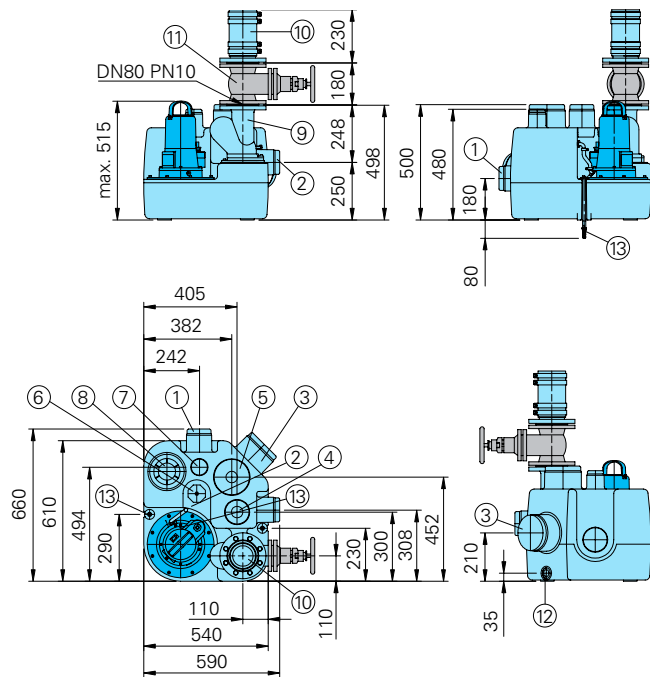

Sekamatik 100 D

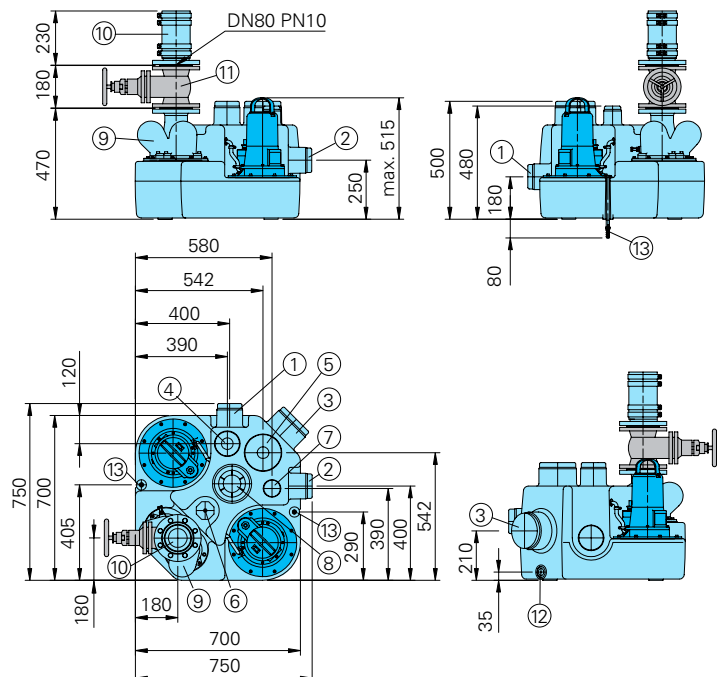

# Installation.

Main inlet vertical

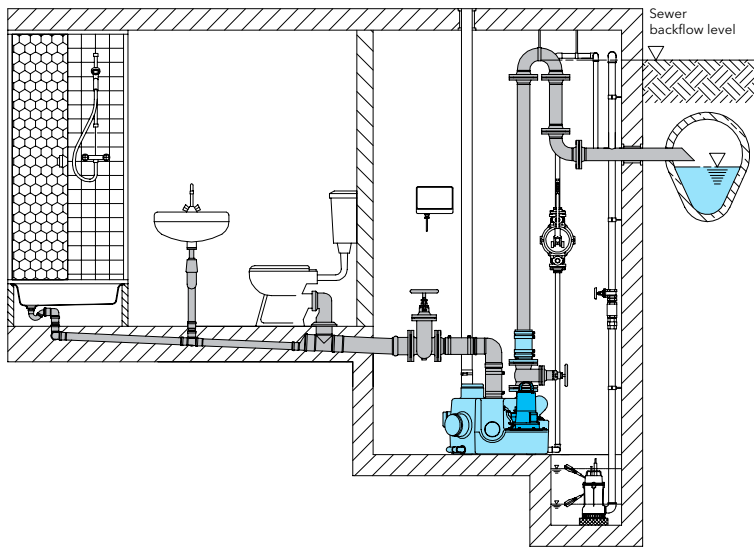

Direct connection

Euro WC

(Inlet height 180 mm)

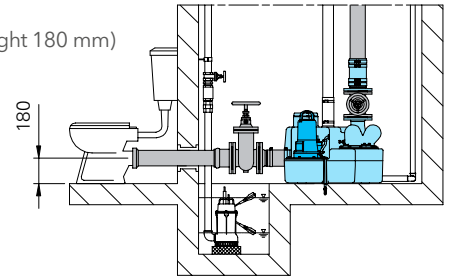

Direct connection

Wall hung WC

(Inlet height 250 mm)

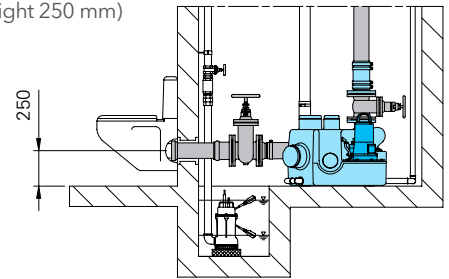

## Dimensions.

(all dimensions are in mm.)

1. Horizontal inlet DN 100
2. Horizontal inlet DN 100
3. Horizontal inlet DN 150
4. Vertical inlet DN 100/DN 40
5. Vertical inlet DN 150/DN 40
6. Connection for pneumatic control box
7. Air vent DN 70
8. Cleaning cover
9. Soft ball check valve DN 80
10. Elastic union piece
11. Flanged gate valve DN 80
12. Connection for diaphragm pump BSP 1"
13. Tank fixing point

# Sekamatik 300

## COMPACT SEWAGE DISPOSAL UNITS WITH LARGE TANK CAPACITY.

### Overview.

Sekamatik 300 compact sewage disposal units are suitable for pumping sewage and wastewater from areas below the sewer backflow level (see DIN EN 12056). With their large tank capacity with extremely compact dimensions they are the ideal solution for the disposal of larger private, commercial or public buildings.

The compact design with various inlets and integrated double soft ball check valve allows a packed installation with minimum space requirement.

**DIN EN 12050-1:** Conformity and design approved and controlled by LGA.

**Pumped liquid:** Clear water or drainage water, wastewater or sewage containing soft solids.

Max. liquid temperature: 35°C, short term up to 60°C.

**Operation:** Intermittent.

### Construction.

**Flood protected twin pump lifting station available as:**

- Sekamatik 300 D: disposal unit with one 300 liters - tank and 2 pumps. Available also with only 1 pump upon request.
- Sekamatik 300 TD: disposal unit with two 300 liters - tanks in tandem arrangement with 1 pump each.

#### Inlets:

- DN 150 horizontal, 300 mm height.
- DN 150 vertical, 400 mm height, with 90°- moulded piece (accessory) as horizontal inlet 600 mm or higher, horizontally adjustable.
- DN 100 vertical, 700 mm height.
- 2 x DN 150 connection for tank in tandem arrangement.

**Collecting tank:** Odour and gas tight composite collecting tank.

**Discharge:** Flange DN 80. Flexible union piece DN 80 / DN 100.

With integrated soft ball check valve.

Air vent: DN 70 vertical. Connection for diaphragm pump BSP 1" F.

Cleaning cover with screw cap.

**Pump:** Pump chamber integrated in the collecting tank. Vortex impeller, spherical clearance 45 mm.

**Motor:** Fully submersible, pressure-tight electric motor, 1 phase or 3 phase. Thermal sensors embedded in the winding. Insulation class F. Degree of protection IP 68. Large diameter stainless steel rotor shaft, pre-lubricated bearings.

**Seals:** Triple lip seal combination in separate oil chamber. Oil inspection from outside.

### Materials.

Collecting tank with pump housing	Polyethylene
Impeller, pump flange	Cast iron
	GG 25/EN-GJL-250
Rotor shaft, screws	Stainless steel
Seal kit	NBR

### Technical Data.

Curve No.	Type Sekamatik 300	Motor input P <sub>1</sub> (kW)	Motor output P <sub>2</sub> (kW)	Voltage 50 Hz (V)	Speed (U/min)	Nominal current (A)	Weight (kg)
①	300 D/TD 23M	2,3	1,7	230-240/1Ph	1450	10,7	132 / 204
①	300 D/TD 23T	2,3	1,7	400-415/3Ph	1450	4,4	132 / 204
②	300 D/TD 37T	3,7	2,9	400-415/3Ph	1450	6,5	148 / 220
③	300 D/TD 30T	3,0	2,1	400-415/3Ph	2900	5,1	132 / 204
④	300 D/TD 40T	4,0	3,3	400-415/3Ph	2900	6,6	148 / 220



Cable	Type	Length
Unit-		
Control box	2 x H07RN-F7 G1,5	3 m
Control box- plug	Model M: H07RN-F 3G1,5 plug 230 V Model T: H07RN-F 5G1,5 CEE-plug 16 A / 400 V	0,8 m

## Performance.

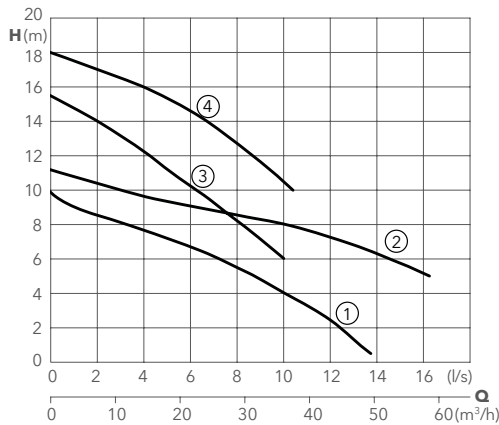

## Controls.

Electronic control box for control and monitoring of all important functions. Pneumatic level control with pressure operation. Auto-change over after each pump cycle. Operation of both pumps at high flow. In the event of failure automatic change over to the second pump. Motor protection with temperature control of the winding. Optical failure alarm. Acoustic alarm by buzzer. Volt free contact for remote signal. Control indication for direction of rotation.

## Dimensions

1. Inlet DN 150 horizontal
2. Inlet DN 150 vertical, alternatively usable with an elbow (accessory) as 90° horizontal inlet
3. Inlet DN 100 vertical
4. Connection for pneumatic control box
5. Air vent DN 70
6. Cleaning cover
7. Soft ball check valve DN 80
8. Elastic union piece
9. Flanged gate valve DN 80 (accessory)
10. Connection for diaphragm pump BSP 1"
11. Elastic union piece DN 150, 200 mm long
12. Uplift safety
13. Connection piece DN 100 (accessory)
14. Connection DN 150 Tandem-double-unit
15. Blind flange

## Dimensions.

(all dimensions are in mm.)

### Sekamatik 300 D...

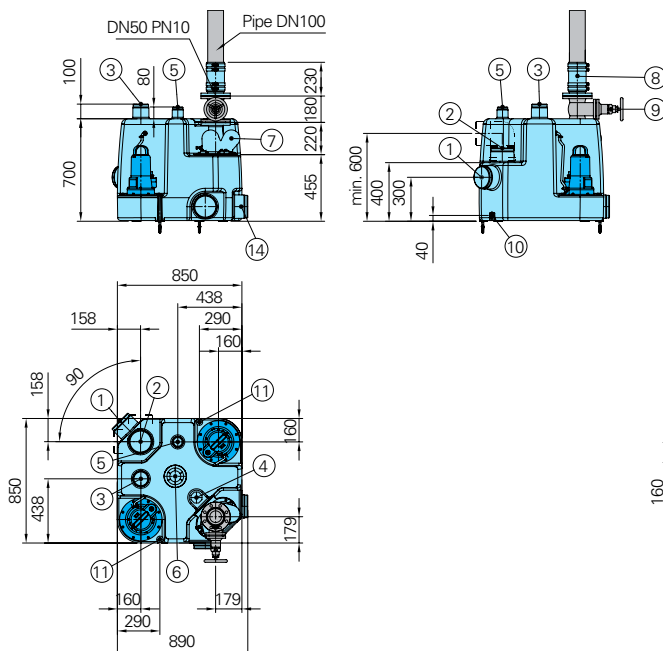

### Sekamatik 300 TD...

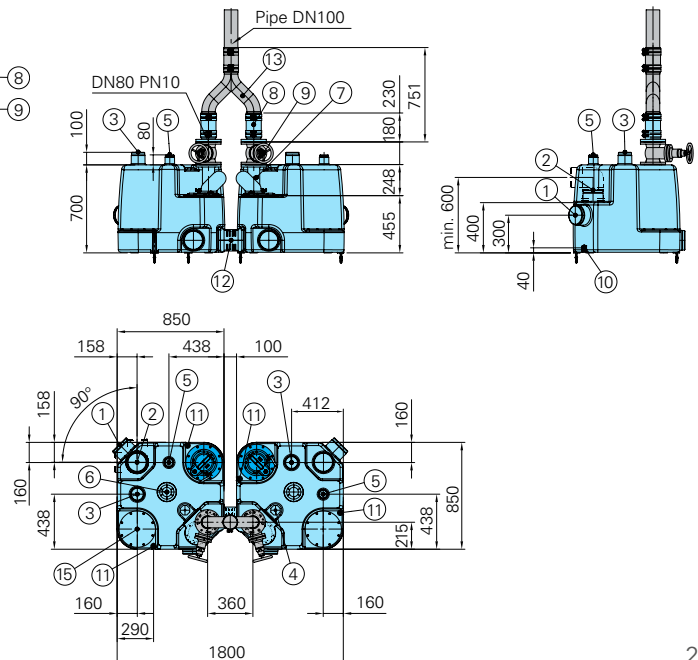

# Sekamatik 400 / 800

## COMPACT SEWAGE DISPOSAL UNIT WITH PLASTIC TANK.

### Overview.

The Sekamatik 400/800 range of compact sewage disposal units is suitable for pumping sewage and wastewater from areas below the sewer level (see DIN EN 12056). With their large tank volumes and high performance submersible wastewater pumps they are perfect for large private, commercial or public buildings, hospitals, schools etc. The compact design allows installation with minimum space available.

The horizontal pump position with the straight-thru tank-pump discharge connection eliminates elbows.

The tanks are available with 400 and 800 liters volume.

**DIN EN 12050-1:** Conformity and design approved and controlled by LGA.

**Pumped liquid:** Clear water or drainage water, wastewater or sewage containing soft solids.

Max. liquid temperature: 35°C, short term up to 60°C.

**Operation:** Intermittent.

### Specifications.

Flood protected single or twin pump lifting station consisting of:

**Collecting tank:** Odour and gas tight tank.

**Plastic tank:** Total volume 400 lt, tandem installation with two tanks 800 lt volume.

**Inlets:**

- Horizontal: DN 150 (3x).
- Vertical: DN 100.

Air vent DN 70. Connection for diaphragm pump DN 50. Cleaning cover with screw cap. Connections for pneumatic level control and float switch.

**Pumps:** Single stage sewage pumps. Horizontal installation, discharge vertical.

**Impellers:** Enclosed single-vane impeller or vortex impeller.

**Motors:** Fully submersible, pressure tight electric motors 400-415 V / 3 Ph. Thermal sensors embedded in the winding. Insulation class H. Degree of protection IP 68. Large diameter stainless steel rotor shaft, pre-lubricated bearings.

**Seals:** Combination of two mechanical seals (silicon-carbide) in a separate oil chamber. Oil inspection from outside.



## Materials.

Collecting tank	Polyethylene
Motor housing, pump housing, impeller	Cast iron
Rotor shaft, screws	GG25/EN-GJL-250
Seal kit	Stainless steel
	NBR

## Technical Data.

### Pump types

Curv no.	Pump type	Motor output P <sub>2</sub> (kW)	Speed (rpm)	Nominal current (A)	Weight (kg)
<b>Discharge DN 80</b>					
Spherical clearance 70 mm					
①	408 PE ... 9T	0,9	1450	2,6	40
②	408 PE ... 13T	1,3	1450	3,4	40
③	408 PE ... 19T	1,9	1450	5,5	66
④	408 PE ... 24T	2,4	1450	6,3	66
⑤	408 PE ... 29T	2,9	2900	6,3	56

<b>Discharge DN 100</b>					
Spherical clearance 80/100 mm					
⑥	410 PE ... 26TA	2,6	1450	6,2	71
⑦	410 PE ... 26T	2,6	1450	6,2	71
⑧	410 PE ... 50T	5,0	1450	9,9	113
⑨	410 PE ... 65TA	6,5	1450	13,1	118
⑩	410 PE ... 65T	6,5	1450	13,1	118
⑪	410 PE ... 95T	9,5	2900	18,8	105
⑫	410 PE ... 115TA	11,5	2900	22,2	110
⑬	410 PE ... 115T	11,5	2900	22,2	110

### Tank types

Type	Material	Total volume	Operating volume
PE E/D	Polyethylene	400 l	220 l
PE TD	Polyethylene	800 l*	440 l

\* 2 tanks in tandem installation

## Performance.

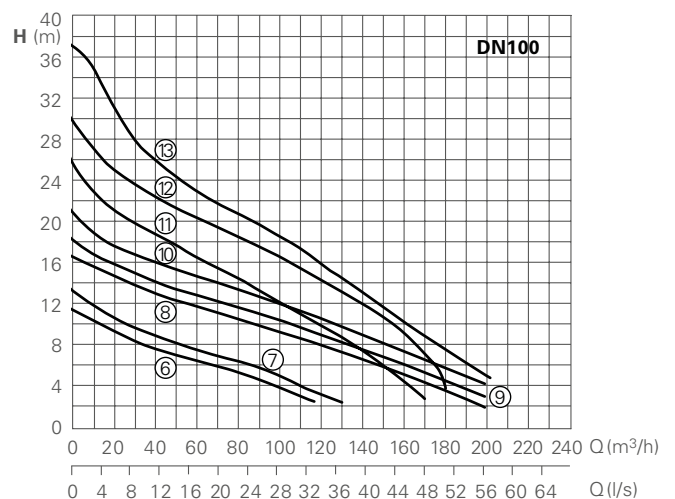
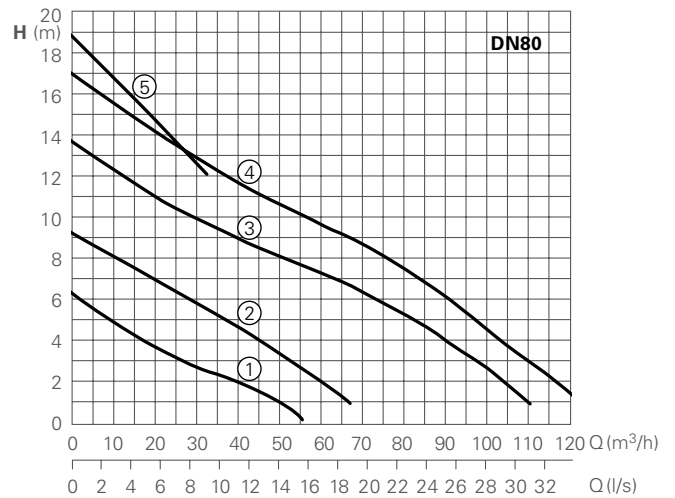

## Combinations of tanks and pumps

Pump types	available in combination with tank types:	
	400 liters	800 liters
408 PE ... 9T	E+D	-
408 PE ... 13T	E+D	-
408 PE ... 19T	E+D	-
408 PE ... 24T	E+D	-
408 PE ... 29T	E+D	-
410 PE ... 26TA	E+D	TD
410 PE ... 26T	E+D	TD
410 PE ... 50T	E+D	TD
410 PE ... 65TA	E+D	TD
410 PE ... 65T	E+D	TD
410 PE ... 95T	E+D	TD
410 PE ... 115TA	E+D	TD
410 PE ... 115T	E+D	TD

## Equipment supplied.

Tank with 1 pump or 2 pumps. Elastic hose connections with bands for tank inlet, connection tank-pump, air vent and diaphragm pump. 1 Elastic union piece DN 100 per pump for discharge connection (with flange DN 80 or DN 100 depending on the pump type). Pneumatic level control. Electronic control panel.

E+D: Available as single tank pump station with 1 pump (E) or with 2 pumps (D)

TD: Available as twin tanks (tandem) pump station with two pumps

## Controls.

Control panel  
Pneumatic level control with pressure operation. Available with float switch control on request. Electronic control box for control and monitoring of all main functions.

Tank types PE E / D / TD...

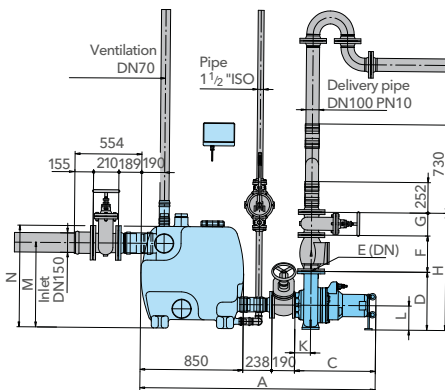

PE E ... / PE D ...

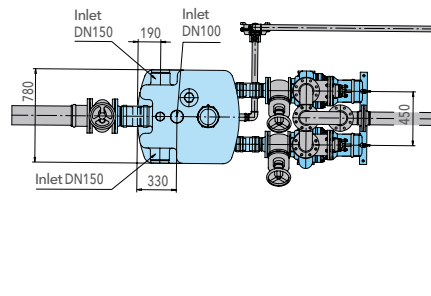

PE TD ...

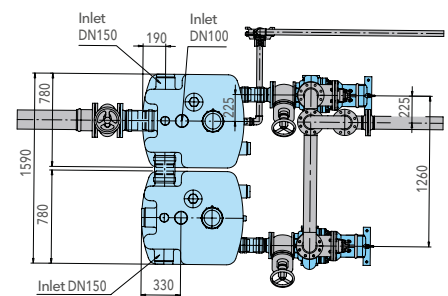

## Dimensions.

(all dimensions are in mm.)

Station type	Pump type	Dimensions												
		A	A1	B	C	D	E	F	G	H	K	L	M	N
PE E ... / PE D ...	9T - 13T	1713	-	-	435	369	80	260	180	809	90	200	700	840
	19T - 24T	1754	-	-	476	440	80	260	180	880	93	200	700	840
	29T	1750	-	-	472	369	80	260	180	809	90	200	700	840
	26TA - 26T	1769	-	-	491	400	100	300	190	890	93	200	700	840
	50T - 65TA - 65T	1946	-	-	668	480	100	300	190	970	130	200	700	840
	95T - 115TA - 115T	1896	-	-	618	400	100	300	190	890	93	200	700	840
PE TD ...	26TA - 26T	1769	-	-	491	400	100	300	190	890	93	200	700	840
	50T - 65TA - 65T	1946	-	-	668	480	100	300	190	970	130	200	700	840
	95T - 115TA - 115T	1896	-	-	618	400	100	300	190	890	93	200	700	840



# Installation.

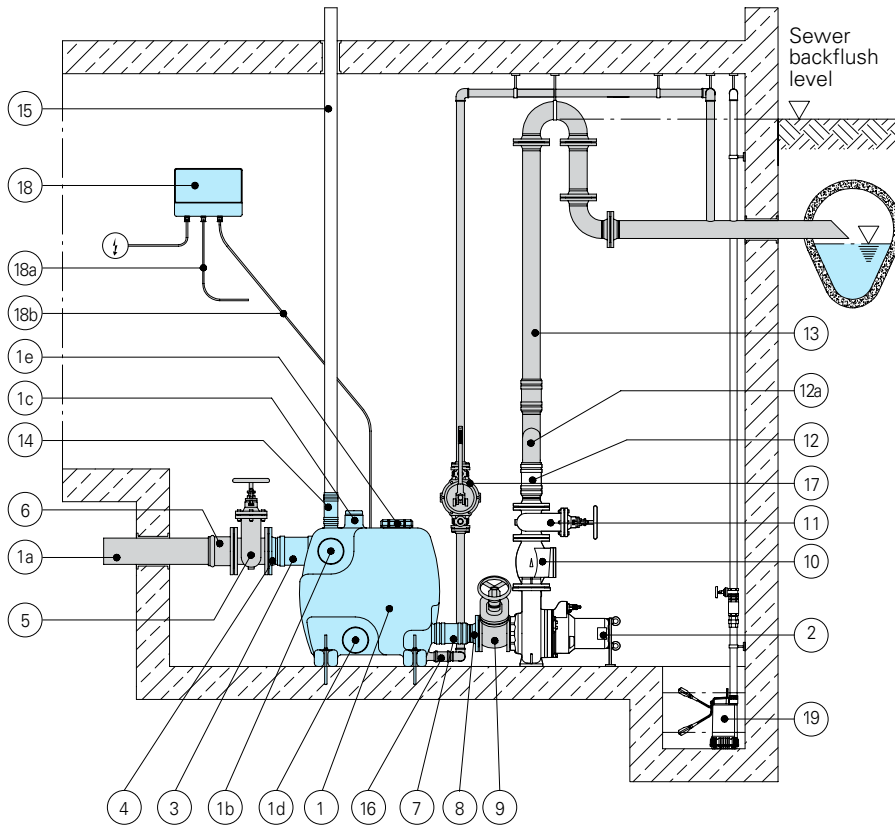

1. Collecting tank \*
- 1a. Horizontal inlet
- 1b. Alternative horizontal inlet/upper tank connection
- 1c. Vertical inlet
- 1d. Lower tank connection
- 1e. Cleaning cover
2. Sewage pump \*
3. Elastic hose connector, inlet \*
4. Flanged pipe socket
5. Flanged gate valve with gasket and fixing bolts, tank inlet
6. Flanged socket with gasket and fixing bolts
7. Elastic hose connector \*
8. Flanged pipe socket \*
9. Flanged gate valve with gasket and fixing bolts, pump inlet
10. Flanged swing check valve with gasket and screws, cleaning cover and aeration fixture
11. Flanged gate valve with gasket and fixing bolts, discharge pipe
12. Flanged elastic piece with gasket and screws \*\*
- 12a. Flanged union piece with gasket and screws for twin pump station PE 40 ditto for twin pump station PE 80
13. Flanged discharge pipe consisting of:
  - Flanged FF-piece, gasket and screws
  - additional m
  - 90° flanged elbow with gasket and screws
  - 180° flanged elbow with gasket and screws
14. Elastic union piece for air vent pipe \*
15. Air vent pipe
16. Elastic union piece for diaphragm pump \*
17. Diaphragm pump
18. Control panel with pneumatic or float switch level control\*
- 18a. Power cable for pump motor
- 18b. Pneumatic pressure hose \*
19. Submersible drainage pump

\* equipment supplied

\*\* equipment supplied depending on pump discharge size

# MINIBOX

## Specifications.

The station is equipped with:

- DOC submersible pump, with flow rate up to 230 l/min and head up to 11 m.
- Passes suspended solids up to 10 mm diameter.
- Equipped with float switch for automatic operation.
- 85 liters high density polyethylene tank.
- 1 1/4" flexible pipe equipped with a check valve; left or right hand connection.
- Power cord outlet.
- Three types of 40 mm diameter pipe inlets.
- Screens.
- Basin to be filled with sand or gravel to filter solid particles.

The Minibox station can be equipped with a DOC3 (0,25 kW rating) or a DOC7 (0,55 kW rating).

Installation is quick and easy: just connect the pipes and plug it in.

Minibox can be installed on the floor or buried in a suitable structure (to withstand vehicle or foot traffic).

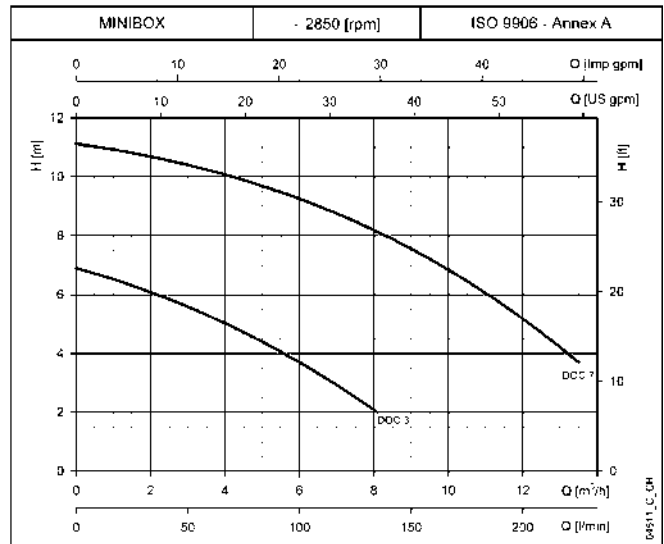

## Dimensions and weights.

(all dimensions are in mm.)

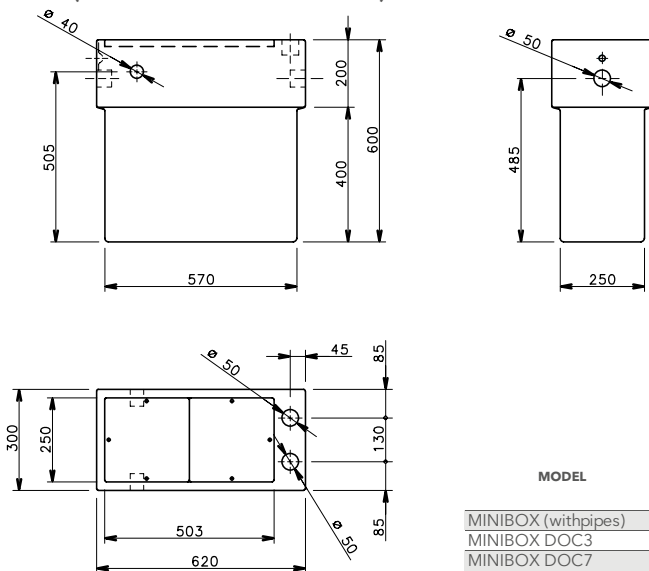

MODEL	WEIGHT kg
MINIBOX (withpipes)	13
MINIBOX DOC3	18
MINIBOX DOC7	20

minibox-en\_a\_td

# MIDIBOX

## Specifications.

The station is equipped with:

- Polyethylene basin with a capacity of 110 liters, equipped with a threaded cover.
- Cable glands for power supply cables (and floats).
- Rp 1 1/4 or Rp 1 1/2 delivery pipes with fast connection and ring nut for easy disassembly of the pump.
- 3 fast connections:  
1 x DN110 for inlet, 1 x DN50 for ventilation and 1 x DN65 for cable connection.
- 1 x DN50 fast connection for the manual pump.
- DOC or DOMO 7 submersible pump, vortex or channel impeller type.
- QDR control panel for three-phase versions.

Versions with vortex impeller suitable for:

- clean water, effluent, sewage containing suspended solids and fibres but non-faecal wastewater.

Versions with single or twin channel impeller suitable for:

- clean water, effluent, sewage not containing suspended fibres and faecal wastewater.

Midibox can be installed on the floor or buried in a suitable structure following instructions in the "Instructions and Operative Manual".

Easy installation:

- Installation is quick and easy: for the single-phase versions you just connect the pipes and the electrical cables; for the three-phase versions you also need to connect the control panel.
- The new Midibox is provided with side handles for ease of handling.
- Pre-installed delivery pump and unions.

Ecological solution:

- tank made from 100% recyclable polyethylene.

Easy maintenance and repair.

- Tried and tested pump technology.
- Pump quick and easy to remove thanks to the ring nut located near the cover.

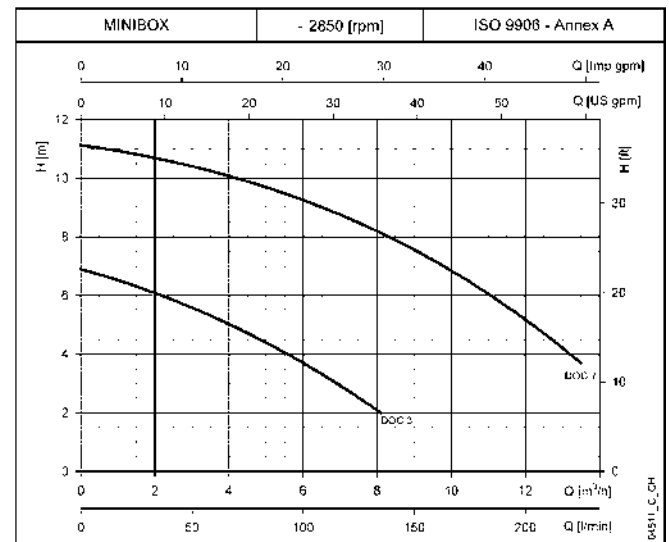

## Dimensions and weights.

(all dimensions are in mm.)

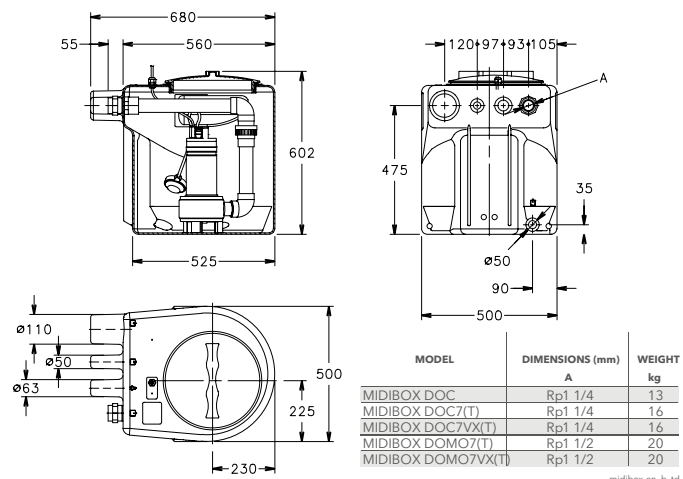

# SINGLEBOX PLUS

## Specifications.

The standard station is equipped with:

- polyethylene basin with a capacity of 270 liters, equipped with a threaded pedestrian cover (100 kg max).
- Cable glands for power supply cables (and floats).
- Rp 1 1/2 or Rp 2 delivery pipes with fast connection and ring nut for easy disassembly of the pump or with sliding device.
- 4 fast connections:  
2 x DN110 for inlet, 1 x DN50 for ventilation and 1 x DN65 for cable connection.
- 1 x DN50 fast connection for the manual pump.
- DOMO or DL submersible pump, vortex, channel impeller type or with grinder device.
- QDR control panel for three-phase versions.
- 3 rubber seal: 1 x DN110, 1 x DN50 and 1 x DN65 mm.

Versions with vortex impeller or with grinder device suitable for:

- clean water, effluent, sewage containing suspended solids and fibres.

Versions with single or twin channel impeller suitable for:

- clean water, effluent, sewage containing suspended solids but not containing fibres.

Special versions equipped with delivery pipes, ball check valve and gate valve.

Special versions equipped with sliding device and non-return ball valve.

Singlebox plus can be installed on the floor or buried in a suitable structure following instructions in the "Instructions and Operative Manual".



Easy installation:

- installation is quick and easy: for the single-phase versions you just connect the pipes and the electrical cables; for the three-phase versions you also need to connect the control panel.
- The new Singlebox plus is provided with side handles for ease of handling.
- Pre-installed delivery pump and unions.

Ecological solution:

- tank made from 100% recyclable polyethylene.
- Airtight anti-pollution tank, pursuant to European standard EN 12050.

Easy maintenance and repair.

- Tried and tested pump technology.
- Pump quick and easy to remove thanks to the ring nut located near the cover.

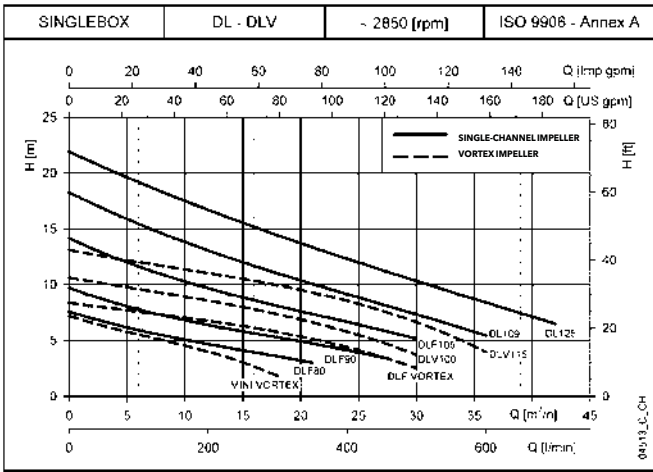
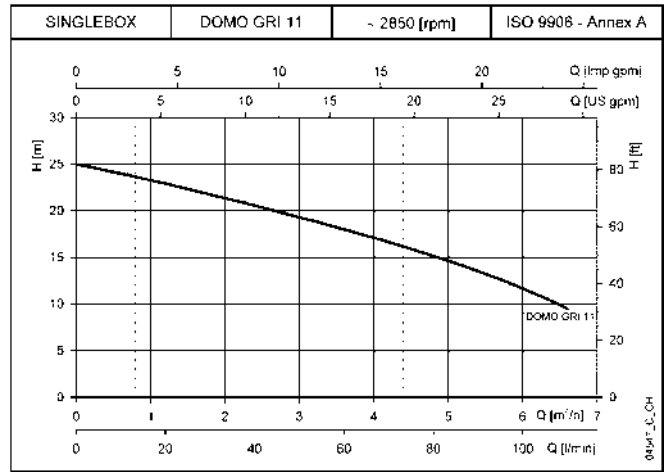
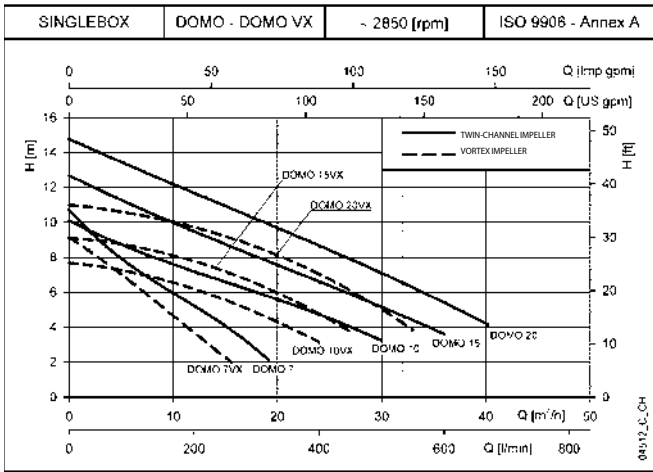

## Dimensions and weights.

(all dimensions are in mm.)

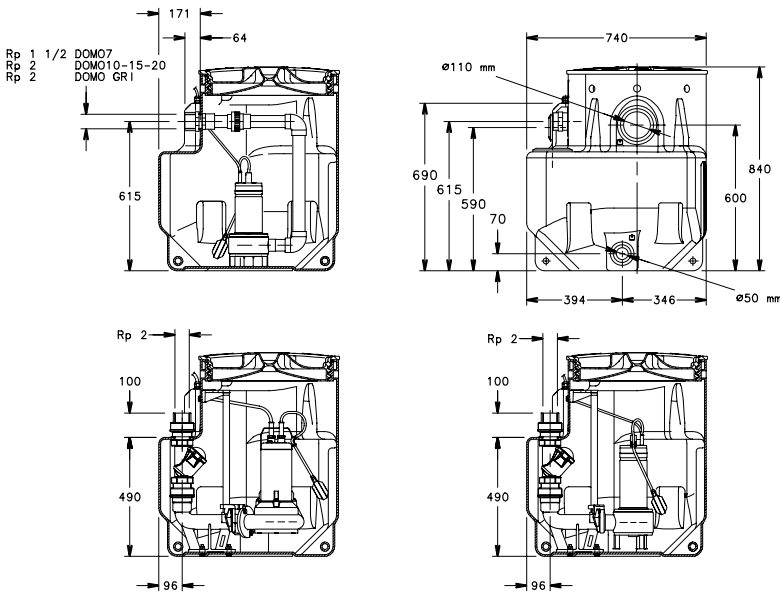

MODEL	WEIGHT (kg)			
	PVC	PVC BV	SL	SL BV
SINGLEBOX PLUS	23	27	32	36

# DOUBLEBOX PLUS

## Specifications.

The standard station is equipped with:

- polyethylene basin with a capacity of 550 liters, equipped with two threaded pedestrian covers (100 kg max).
- Cable glands for power supply cables (and floats).
- 2x Rp 1 1/2 or Rp 2 delivery pipes with fast connections and ring nuts for easy disassembly of the pumps or with sliding device.
- 8 fast connections:  
4 x DN110 for inlet, 2 x DN50 for ventilation and 2 x DN65 for cable connection.
- 1 x DN50 fast connection for the manual pump.
- 2x DOMO or DL submersible pumps, vortex, channel impeller type or with grinder device.
- QDR2 control panel for three-phase versions.
- 3 rubber seals:  
1 x DN110, 1 x DN50 and 1 x DN65 mm.

Versions with vortex impeller or with grinder device suitable for:

- clean water, effluent, sewage containing suspended solids and fibres.

Versions with single or twin channel impeller suitable for:

- clean water, effluent, sewage containing suspended solids but not containing fibres.

Special versions equipped with delivery pipes, ball check valve and gate valve.

Special versions equipped with sliding device and non-return ball valve.

Doublebox plus can be installed on the floor or buried in a suitable structure following instructions in the "Instructions and Operative Manual".



Easy installation:

- installation is quick and easy:  
for the single-phase versions you just connect the pipes and the electrical cables; for the three-phase versions you also need to connect the control panel.
- The new Doublebox plus is provided with side handles for ease of handling.
- Pre-installed delivery pump and unions.

Ecological solution:

- tank made from 100% recyclable polyethylene.
- Airtight anti-pollution tank, pursuant to European standard EN 12050.

Easy maintenance and repair.

- Tried and tested pump technology.
- Pump quick and easy to remove thanks to the ring nut located near the cover.

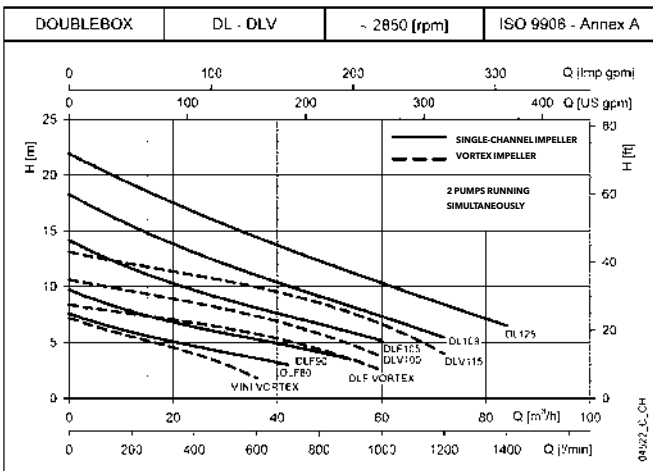
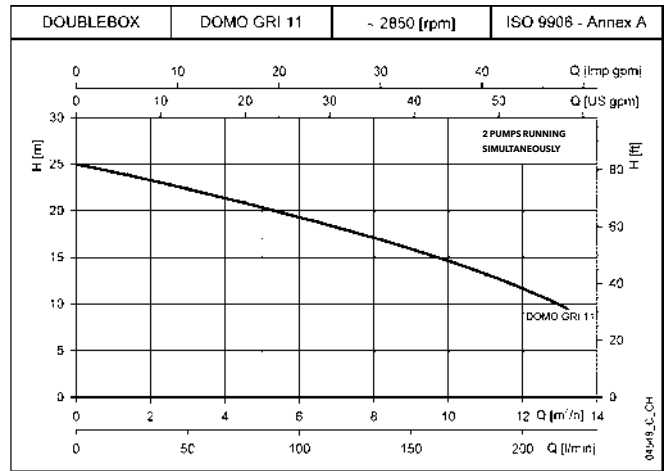
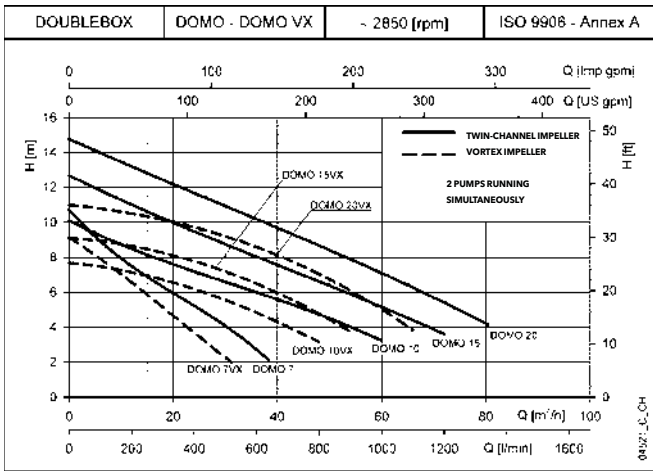

### Dimensions and weights. (all dimensions are in mm.)

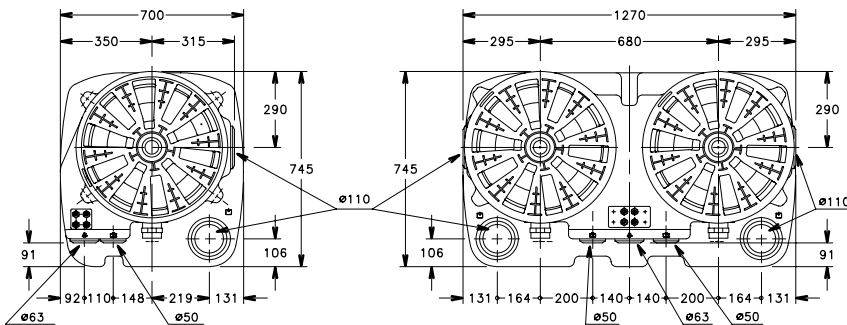

MODEL	WEIGHT (kg)			
	PVC	PVC BV	SL	SL BV
DOUBLEBOX PLUS	44	51	62	69

sbox-dbox-en\_a\_td

04514\_C\_DD



# MAXIBOX PLUS

## Specifications.

The standard tank is equipped with the following components, already assembled:

- polyethylene basin with a capacity of 1200 or 1900 liters.
- Threaded cover.
- 2 1/2" or 2" delivery pipes.
- 2 DN65 or DN50 sliding device systems.
- 2 ball check valves.
- 2 gate valves.
- Float switches bracket.

The supply also includes:

- Cable glands for power supply cables and floats.
- 1 rubber seal for DN160 inlet connection.

The standard tank doesn't include the pumps, so it must be completed with:

- 2 submersible pumps DOMO, DOMOGRI, DL.
- These have to be ordered separately.
- Lowering devices guideclaws.

Selecting the right pump:

- The pumps with Vortex or Grinder impellers are suitable for clean water, effluent and sewage handling that contain suspended solids and fiber materials.
- The pumps with single or twin channel impellers are suitable for clean water, effluent and sewage handling that contain suspended solids but not fibres.

Maxibox Plus must be installed buried outside the building according to the indications in the installation and operating instructions manual.

Ecological solution:

- tank made of 100% recyclable polyethylene.
- watertight anti-pollution tank, according to the EN 12050-1 European standard.

Easy maintenance and repair thanks to the sliding device systems.



# Dimensions and weights.

(all dimensions are in mm.)

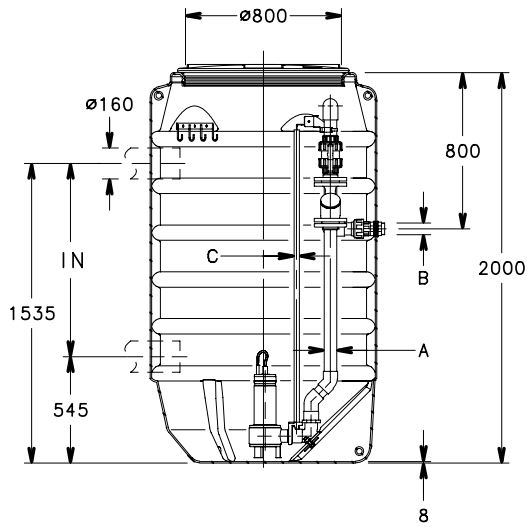
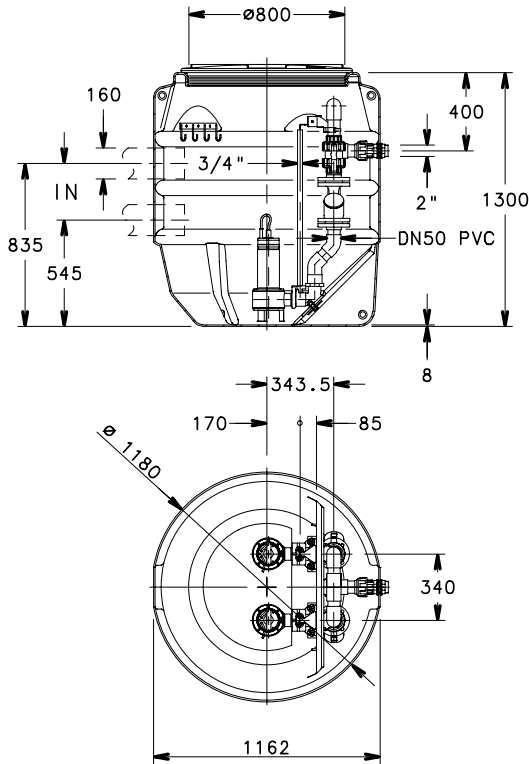

	A	B	C
DN50	DN50	2"	3/4"
DN65	DN65	2 1/2"	2"

04050\_B\_DD

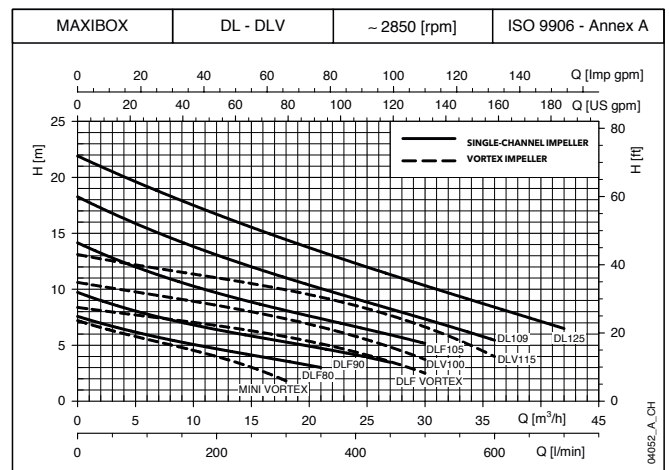
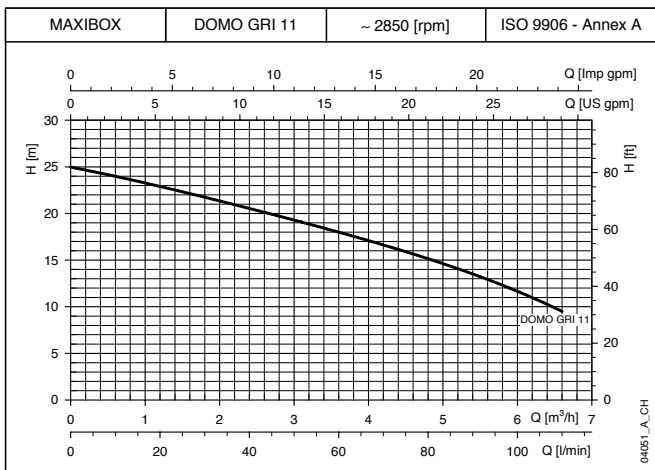
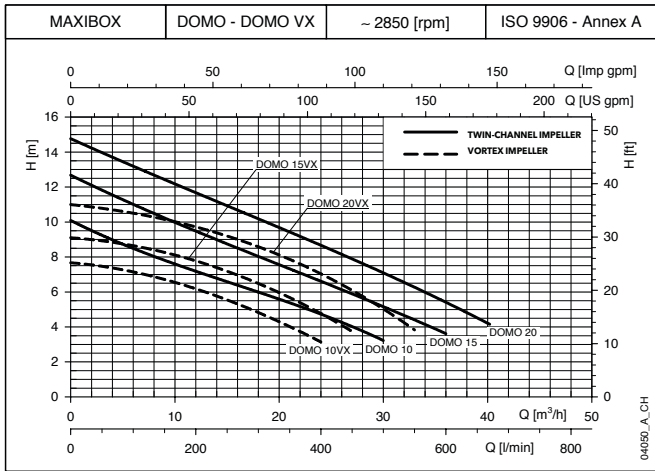

# Xylem |'zīləm|

- 1) The tissue in plants that brings water upward from the roots;
- 2) a leading global water technology company.

We're a global team unified in a common purpose: creating advanced technology solutions to the world's water challenges. Developing new technologies that will improve the way water is used, conserved, and re-used in the future is central to our work. Our products and services move, treat, analyze, monitor and return water to the environment, in public utility, industrial, residential and commercial building services, and agricultural settings. With its October 2016 acquisition of Sensus, Xylem added smart metering, network technologies and advanced data analytics for water, gas and electric utilities to its portfolio of solutions. In more than 150 countries, we have strong, long-standing relationships with customers who know us for our powerful combination of leading product brands and applications expertise with a strong focus on developing comprehensive, sustainable solutions.

**For more information on how Xylem can help you, go to [www.xylem.com](http://www.xylem.com)**



For information and technical support  
Xylem Service Italia Srl

Via Dottor Vittorio Lombardi 14  
36075 - Montecchio Maggiore (VI) - Italy  
Tel. (+39) 0444 707111  
Fax (+39) 0444 491043  
[www.lowara.com](http://www.lowara.com)  
[www.xylem.com](http://www.xylem.com)

Xylem reserves the right to make modification without prior notice.  
Lowara, Flygt and Xylem are trademarks of Xylem Inc. or one of its subsidiaries. © 2018 Xylem, Inc.