



# ISO 2858

## CANNED MOTOR PUMPS

- Compliant to ISO 2858 Standards
- Market Leading Efficiency
- Steadily Rising HQ Performance
- Low NPSH<sub>R</sub>
- Efficient Low Flow, High Head Performance



SAFE, EFFICIENT, COMPLIANT,  
AND STANDARD BY DESIGN.

**RAISING THE STANDARD  
FOR PROCESS PUMPS**

**TEIKOKU ELECTRIC MFG. CO., LTD.**



# FEATURES

1. 100% Compliant to ISO 2858 Requirements For Optimized Standardization
2. Optimized Volute/Impeller Design offers Market Leading Efficiency
3. Steadily Rising HQ Performance through Shutoff TDH
4. Enhanced Impeller Designs for Low  $NPSH_R$
5. Efficient Low Flow, High Head performance with ISO Centerline Discharge eliminates need for inefficient, Low  $N_s$ , Tangential Discharge pumps

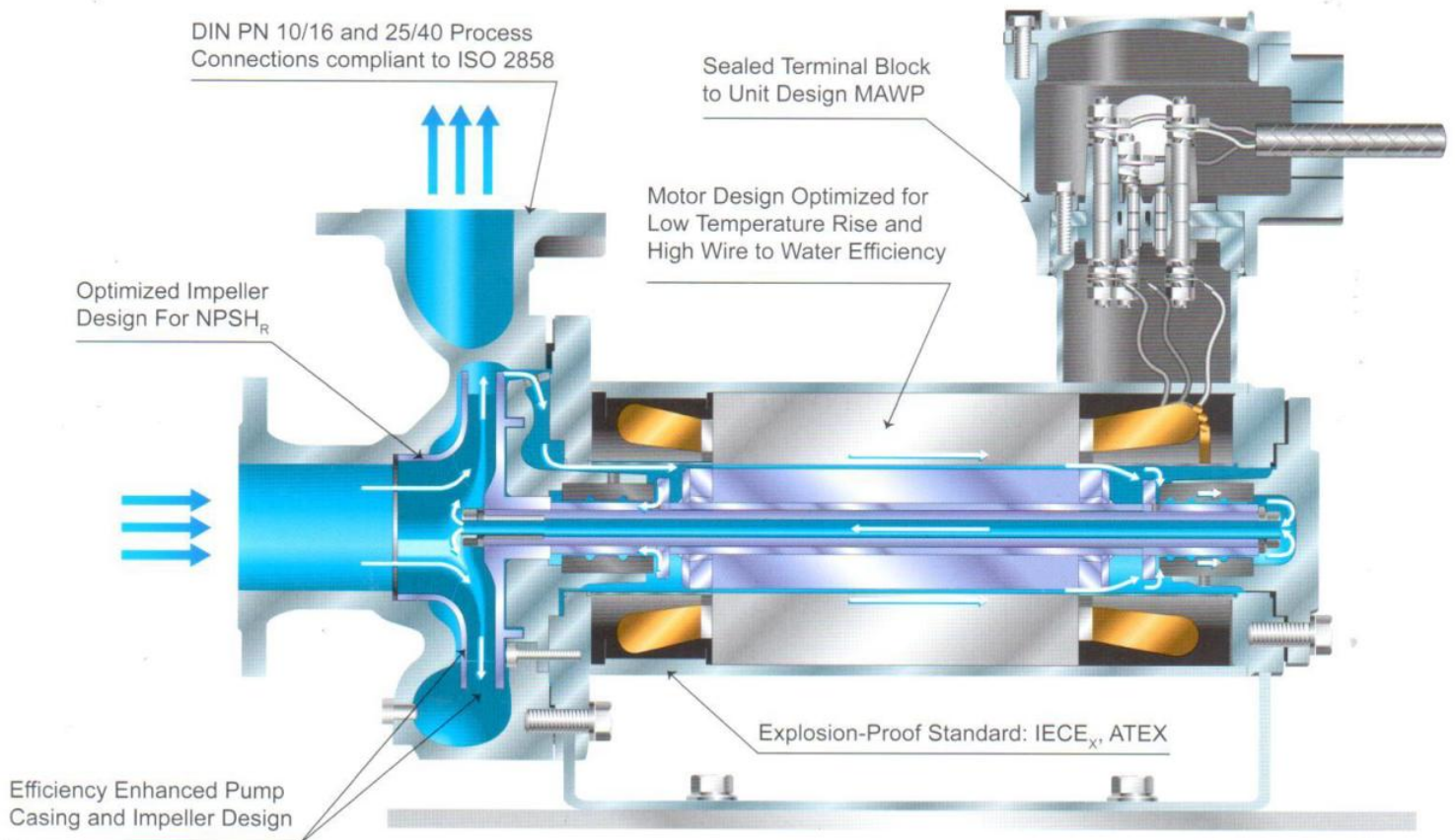

## COMPLIANT TO CURRENT INDUSTRY STANDARDIZED NORMS

*Working Group pumps in the Chemical Industry*

Third Guideline PiC-LF03 2014-03

“Centrifugal pump units - Guideline to DIN EN ISO 2858 - Applications, evaluation, strategies”

- $Q_{BEP}$ : Flow rate at best efficiency point for the specified impeller diameter
- $Q_{ISO}$ : Associated standard nominal duty point
- $SPII$ : Ratio between  $Q_{BEP}$  and  $Q_{ISO}$  ( $Q_{BEP}/Q_{ISO}$ )

TEIKOKU ISO 2858 pumps meet Guideline requirements of  $SPII$  Ratio 1 - 1.15

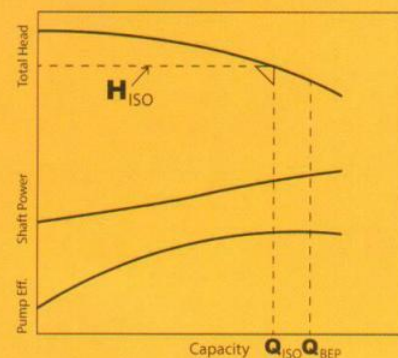



# DESIGNED FOR ZERO-LEAKAGE

TEIKOKU, the world's largest supplier of canned motor pumps, offers a 100 % ISO 2858 compliant sealless pump to drive market demands for standardization and long term sustainability in operations.

No newcomer to the field, TEIKOKU has provided customers with proven Canned Motor Pump solutions for more than 50 years. Over 700,000 units have been installed worldwide, covering every possible application.

TEIKOKU is unique in that it designs and manufactures both pumps and motors, thus ensuring users total quality control and matched hydraulic/driver performance.

The TEIKOKU Canned Motor Pump replaces conventional sealed pumps, providing safer, more economical operation through reduced long-term cost of ownership. This is especially advantageous when pumping hazardous, volatile, toxic, and hard to handle liquids.

TEIKOKU provides expertise in selecting a sealless solution best suited to a user's specific needs. TEIKOKU's experience encompasses horizontal standard pumps, vertical designs with either pump up or motor up configurations, pumps and motors jacketed for cooling or heating, self-priming volutes, submersible units, slurry designs, non-cooled, high temperature insulated motor pumps and more.

## TEIKOKU SOLVES THE SUSTAINABILITY EQUATION

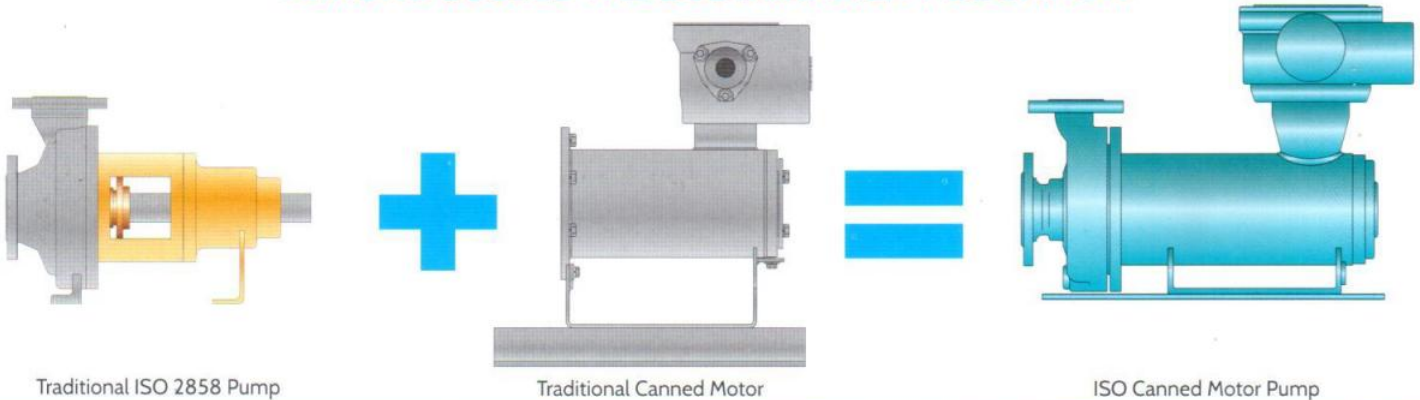

## TEIKOKU ISO PUMP

Designed according to ISO 2858. Teikoku offers a range of 22 ISO 2858 models .

Inlet [mm]	Outlet [mm]	Impeller (nominal) [mm]	1450 [rpm]		2900 [rpm]		TEIKOKU Pump type
			Q [m3/h]	H [m]	Q [m3/h]	H [m]	
50	32	125	6.3	5	12.5	20	0305RC1
50	32	160	6.3	8	12.5	32	0305SC1
50	32	200	6.3	12.5	12.5	50	0305TC1
50	32	250	6.3	20	12.5	80	0305UC1
65	40	160	12.5	8	25	32	0406SC1
65	40	200	12.5	12.5	25	50	0406TC1
65	40	250	12.5	20	25	80	0406UC1
65	40	315	12.5	32	25	125	0406VC1
80	50	160	25	8	50	32	0508SC1
80	50	200	25	12.5	50	50	0508TC1
80	50	250	25	20	50	80	0508UC1
80	50	315	25	32	50	125	0508VC1
100	65	160	50	8	100	32	0610SC1
100	65	200	50	12.5	100	50	0610TC1
100	65	250	50	20	100	80	0610UC1
100	65	315	50	32	100	125	0610VC1
125	80	200	80	12.5	160	50	0812TC1
125	80	250	80	20	160	80	0812UC1
125	80	315	80	32	160	125	0812VC1
125	100	200	125	12.5	250	50	1012TC1
125	100	250	125	20	250	80	1012UC1
125	100	315	125	32	250	125	1012VC1



# ISO 2858 PUMP DESIGN DETAILS

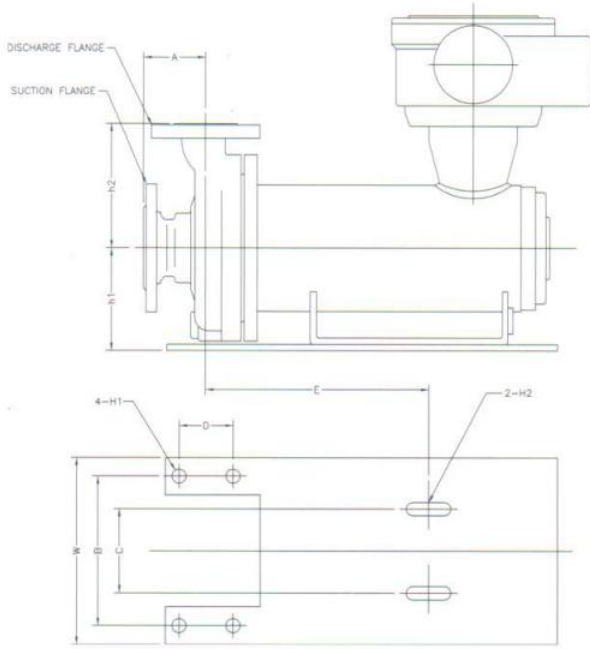

The rating of the applicable flanges is DIN PN 10/16 and DIN PN 25/40. The Flanges comply with DIN EN 1092-1. The pump types that can be combined with the ISO pump hydraulics are shown in the table below.

Teikoku Base Model	Type	API Plan
F, F-V	Basic	1-S
F-R	Pressurized circulation	1-SD
F-X-V	Super heat resistance	1-S
BA	High temperature isolation	23-S
DA	Slurry	53-S

The dimensions of the pump specified in ISO 2858 are shown in the table below.

PUMP SIZE [mm] (Suc.×Dis.×Imp.)	Dimensions [mm]									
	h1	h2	A	W	B	C	D	E	H1	H2
50×32×125	112	140	80	190	140	110	70	285	M12	M12
50×32×160	132	160	80	240	190	110	70	285	M12	M12
50×32×200	160	180	80	240	190	110	70	285	M12	M12
50×32×250	180	225	100	320	250	110	95	370	M12	M12
65×40×160	132	160	80	240	190	110	70	285	M12	M12
65×40×200	160	180	100	265	212	110	70	285	M12	M12
65×40×250	180	225	100	320	250	110	95	370	M12	M12
65×40×315	200	250	125	345	280	110	95	370	M12	M12
80×50×160	160	180	100	265	212	110	70	285	M12	M12
80×50×200	160	200	100	265	212	110	70	285	M12	M12
80×50×250	180	225	125	320	250	110	95	370	M12	M12
80×50×315	225	280	125	345	280	110	95	370	M12	M12
100×65×160	160	200	100	280	212	110	95	370	M12	M12
100×65×200	180	225	100	320	250	110	95	370	M12	M12
100×65×250	200	250	125	360	280	110	120	370	M16	M12
100×65×315	225	280	125	400	315	110	120	370	M16	M12
125×80×200	180	250	125	345	280	110	95	370	M12	M12
125×80×250	225	280	125	400	315	110	120	370	M16	M12
125×80×315	250	315	125	400	315	110	120	370	M16	M12
125×100×200	200	280	125	360	280	110	120	370	M16	M12
125×100×250	225	280	140	400	315	110	120	370	M16	M12
125×100×315	250	315	140	400	315	110	120	370	M16	M12

# RANGE & PERFORMANCE

ISO 2858 PUMPS		
	Standard Range	Extended Range
Capacity (max)	300 M <sup>3</sup> /HR at 60 Hz	
TDH (max)	200 Meters at 60 Hz	
Temperature	-100 to + 350°C	-200 to + 450°C
Viscosity	100 cp	350 cp
Design Pressure	3 MPa	55 MPa
Motor Kilowatts (max)	220 kW	440 kW
Wetted Materials	304SS, 316SS	304L & 316L SS, Duplex2205, Alloy C, Titanium & others by request

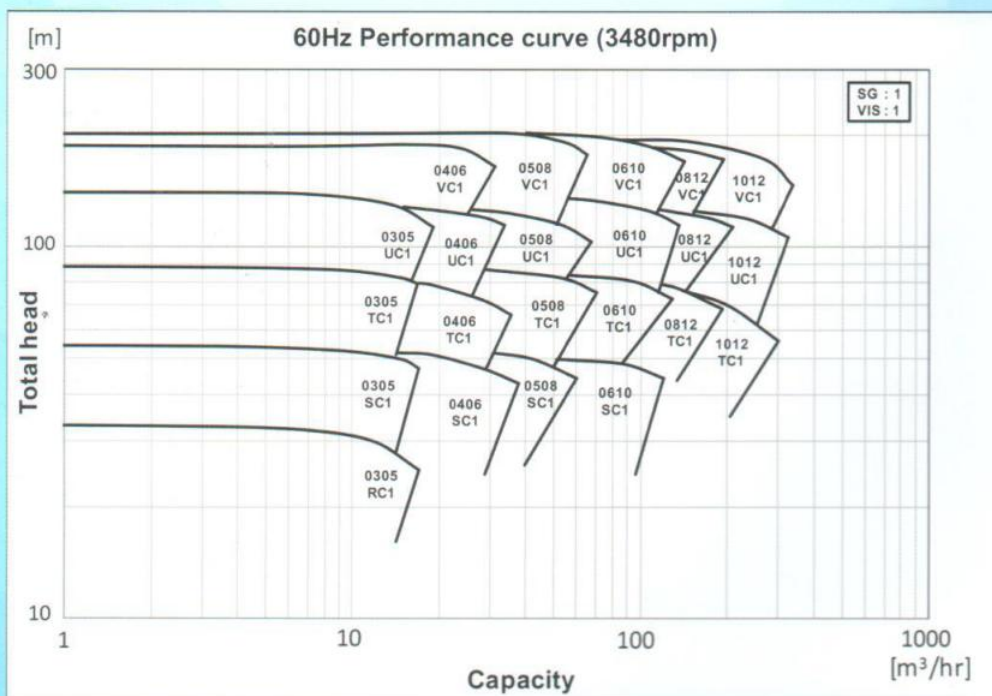
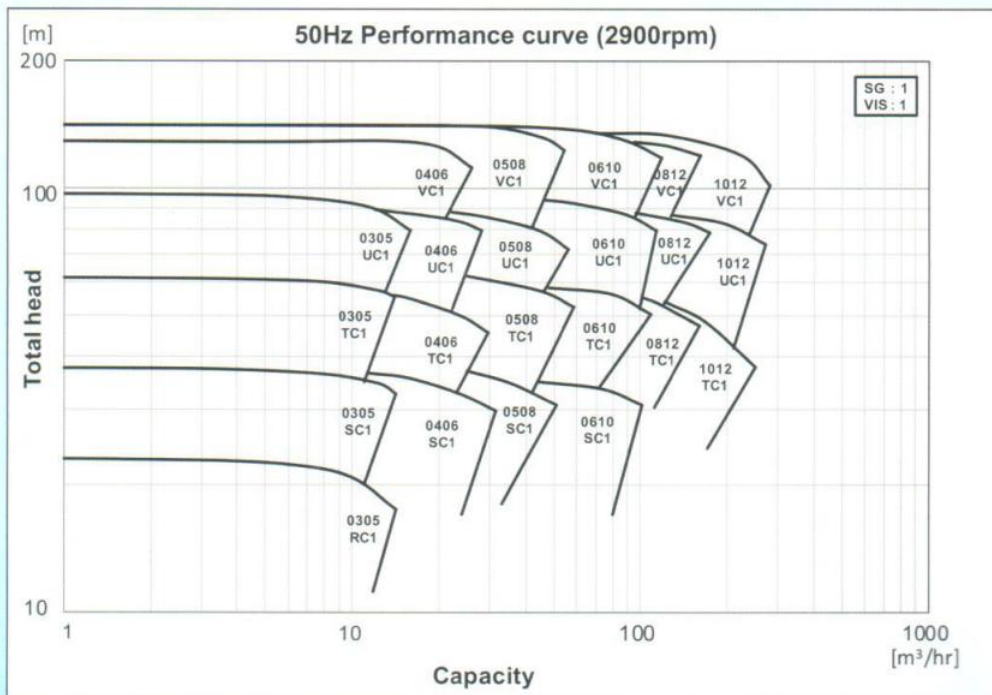



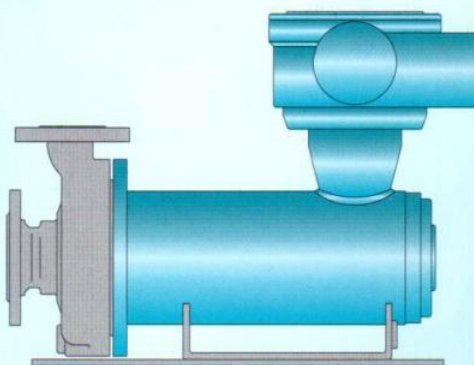
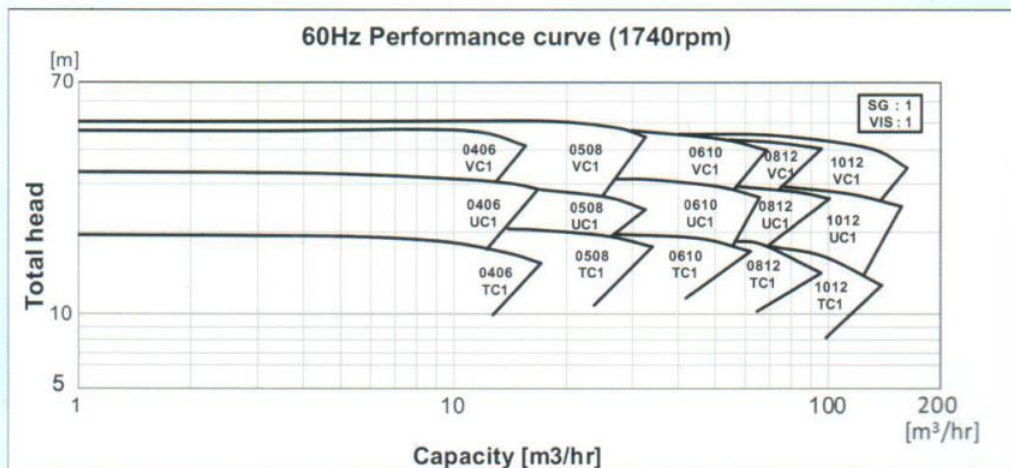
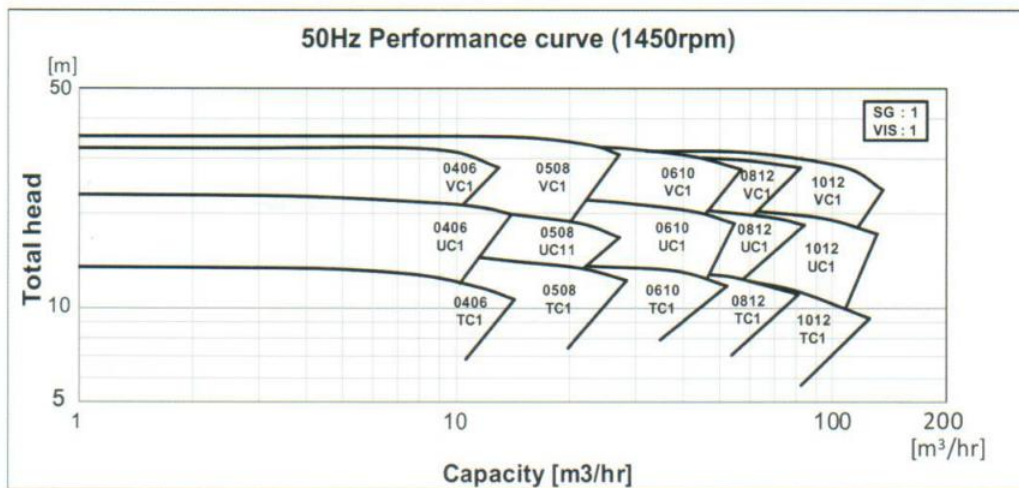

## MOTOR CHARACTERISTICS

Frequency	Dual - 50Hz & 60Hz	
Voltage	3 PH, 190~690VAC	
Power Inlet	M or NPT threaded - e or d IIC, Certified Cable Ground	
Enclosure	Totally Enclosed Liquid Cooled (TELC)	
Insulation Classes	Thermal Class 220, 300 & 400 available	
Safety	CE Mark	
Explosion Proof	IECEX, ATEX Ex db e IIC T1~T6 Gb	
Materials	<b>Stator Liner</b>	Alloy C
	<b>Rotor Liner</b>	316LSS
	<b>Sleeve Bearings</b>	Carbon Graphite Standard
		Silicon Carbide Coating Optional
	<b>Shaft Sleeve Journals</b>	Stellite Coating
		Tungsten Carbide Coating Optional
<b>Axial Thrust Collars</b>	Stellite Coating	
	Tungsten Carbide Coating Optional	

# BEARING WEAR & ROTOR POSITION MONITORS

## TEIKOKU RADIAL GUARDIAN (TRG™) RADIAL WEAR MONITOR

TRG™ creates a magnetic field from embedded coils in the motor winding to induce a controllable voltage output in conjunction with magnets sealed in the rotor. With the rotor centered, the two magnetic fields are balanced.

Upon bearing wear, the gap "B" between the rotor and stator decreases, creating an imbalance. The resulting magnetic flux generates an induced voltage in the TRG™ coils, indicating as wear on the TRG™ meter.

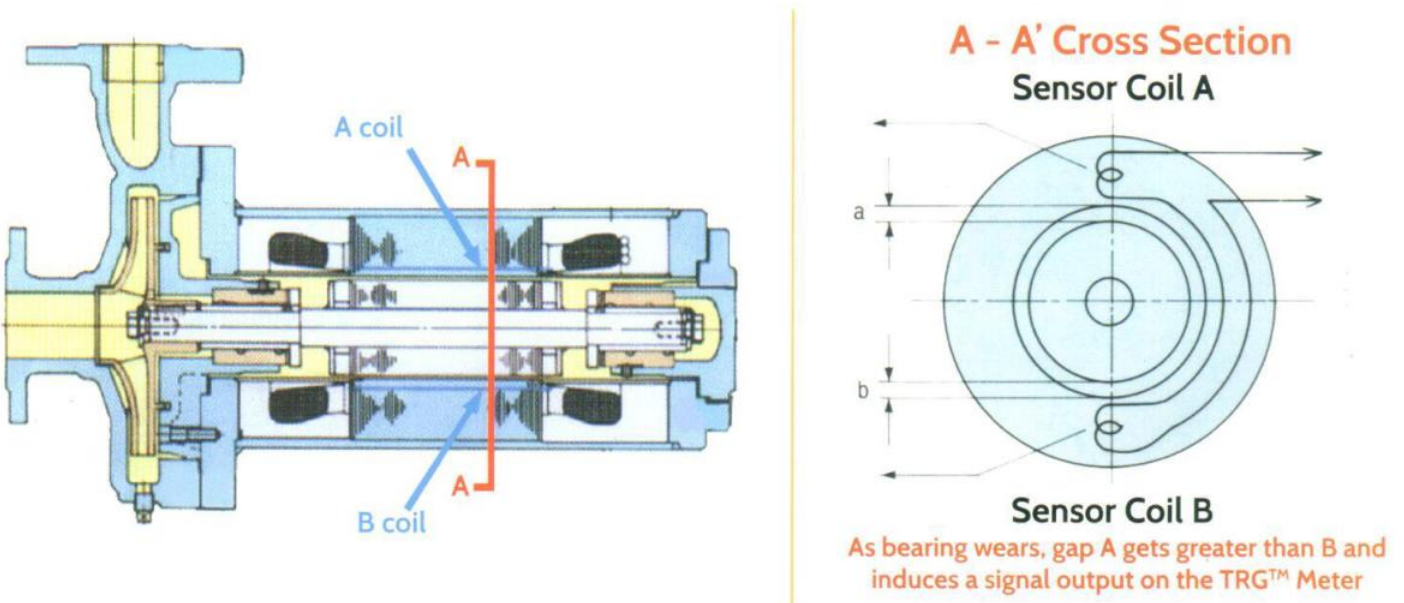

## TEIKOKU HYBRID GUARDIAN (THG™) - AXIAL & RADIAL MONITOR

An output voltage is generated from an embedded sensor that varies with axial rotor position changes. The voltage variation in the output signal is converted to the rotor position and indicated on the THG™ LED display.

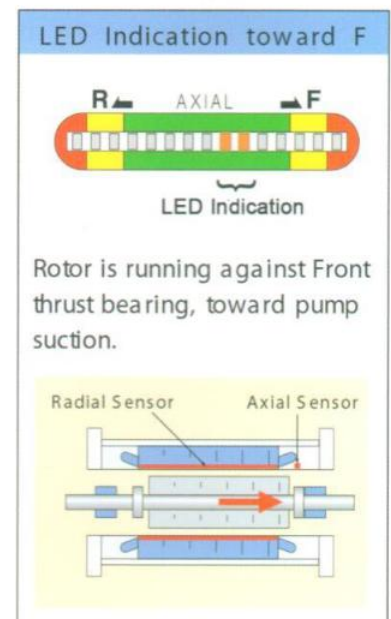
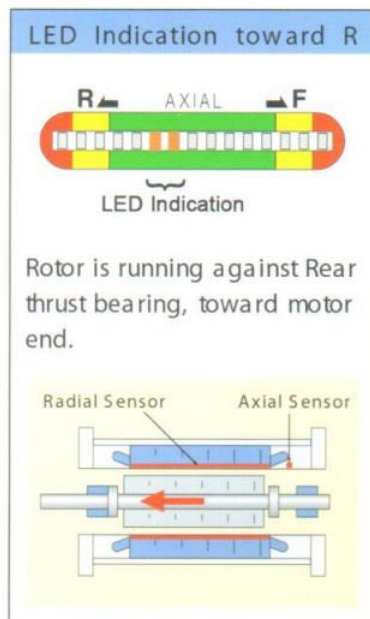
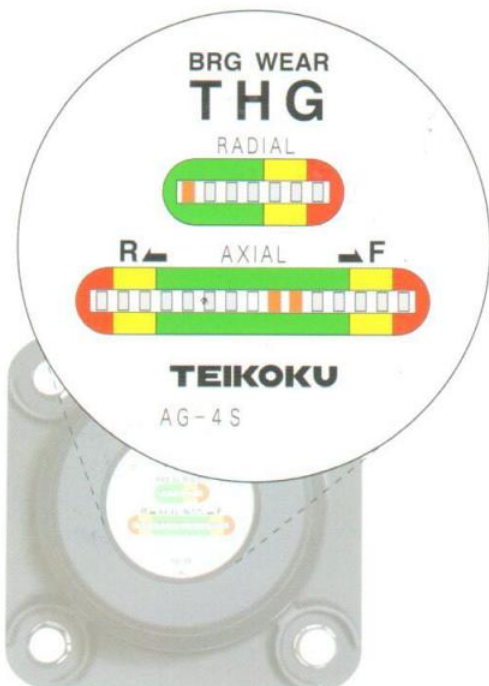



## **TEIKOKU Electric Mfg. Co., Ltd. (Japan)**

Plant & Business Headquarters  
Postcode 679-4395  
60 Hirano, Shingu-Cho, Tatsuno-Shi, Hyogo-Ken, Japan  
Phone: +81-791-75-0411  
[www.teikokudenki.co.jp](http://www.teikokudenki.co.jp)

## **International Business Division**

Postcode: 103-0022  
12F Sakura-Murmachi Bldg. 5-1, 4-Chome,  
Nihombashimuromachi, Chuo-ku, Tokyo, Japan  
Phone: +81-3-3275-3641 Fax: +81-3-3275-9776  
E-mail: [ibd-tokyo@teikokudenki.co.jp](mailto:ibd-tokyo@teikokudenki.co.jp)

## **TEIKOKU USA, Inc. (North & South America)**

959 Mearns Road  
Warminster, PA 18974 USA  
Phone: +1-215-343-6000  
[www.teikokupumps.com](http://www.teikokupumps.com)

## **TEIKOKU USA, Inc. (US Gulf Coast Sales & Service Center)**

5880 Bingle Road  
Houston, TX 77092 USA  
Phone: +1-713-9901  
[www.teikokupumps.com](http://www.teikokupumps.com)

## **Dalian TEIKOKU Canned Motor Pump Co., Ltd. (China)**

Sanjianpu Science & Technology Industry Area  
Dalian, China  
Phone: +86-411-8626-9657  
[www.teikokuchina.com](http://www.teikokuchina.com)

## **Taiwan Teikoku Pump Co., Ltd.**

9F-1 No. 5, Jinzhou St., Zhongshan District  
Taipei City 104, Taiwan, ROC  
Phone: +886-2-2567-9800

ПромХимТех - дистрибьютор и сервисный партнер Teikoku

[www.promhimtech.ru](http://www.promhimtech.ru)  
[zakaz@promhimtech.ru](mailto:zakaz@promhimtech.ru)

## **TEIKOKU Electric GmbH (Europe)**

Muendelheimer Weg 50, 40472  
Duesseldorf, Germany  
Phone: +49-211-700-6778  
[www.teikokupump.de](http://www.teikokupump.de)

## **TEIKOKU South Asia PTE, LTD. (Southeast Asia)**

No. 15 Joo Koon Crescent  
Singapore, 629015  
Phone: +65-6861-4121  
[www.teikokupumps.com](http://www.teikokupumps.com)

## **TEIKOKU Korea Co., Ltd. (Korea)**

5F HB Tower, 25 Nonhyun-ro 87 Gil,  
Gangnam-gu, Seoul, 06236, Korea  
Phone: +82-2-790-7014  
E-mail: [webmaster@TeikokuKorea.co.kr](mailto:webmaster@TeikokuKorea.co.kr)  
[www.teikokukorea.co.kr](http://www.teikokukorea.co.kr)

## **Hydrodyne (India) PVT. LTD.**

Survey No. 18, Hissa No. 3, 4, & 5 of Village Ghodbundar,  
Mira Bhayander Road, Near R.T.O. Office, Mira Road (East),  
Thane 401107, India  
Phone: +91-22-4064-7600  
Fax: +91-22-4064-7634

Visit us online at:  
[www.teikokudenki.co.jp](http://www.teikokudenki.co.jp)