

INTERNATIONAL STANDARD



2858

INTERNATIONAL ORGANIZATION FOR STANDARDIZATION • МЕЖДУНАРОДНАЯ ОРГАНИЗАЦИЯ ПО СТАНДАРТИЗАЦИИ • ORGANISATION INTERNATIONALE DE NORMALISATION

Стандарт ISO 28 58. Вторая редакция 02.15.1975. Центробежные насосы с односторонним всасыванием (16 бар). Обозначение, номинальная рабочая точка и размер.
Standard ISO 2858. Second edition 02.15.1975. End Suction Centrifugal Pumps (rating 16 bar) – designation, nominal duty point and dimension.

End-suction centrifugal pumps (rating 16 bar) – Designation, nominal duty point and dimensions

Pompes centrifuges à aspiration en bout (pression nominale 16 bar) – Désignation, point de fonctionnement nominal et dimensions

Second edition – 1975-02-15

ООО "ПромХимТех"
www.promhimtech.ru

UDC 621.671

Ref. No. ISO 2858-1975 (E)

Descriptors : pumps, centrifugal pumps, dimensions, specifications, designation.

FOREWORD

ISO (the International Organization for Standardization) is a worldwide federation of national standards institutes (ISO Member Bodies). The work of developing International Standards is carried out through ISO Technical Committees. Every Member Body interested in a subject for which a Technical Committee has been set up has the right to be represented on that Committee. International organizations, governmental and non-governmental, in liaison with ISO, also take part in the work.

Draft International Standards adopted by the Technical Committees are circulated to the Member Bodies for approval before their acceptance as International Standards by the ISO Council.

International Standard ISO 2858 (2nd Edition) was drawn up by Technical Committee ISO/TC 115, *Pumps*. It was submitted directly to the ISO Council, in accordance with clause 6.12.1 of the Directives for the technical work of ISO.

This International Standard cancels and replaces International Standard ISO 2858-1973, which had been approved by the Member Bodies of the following countries :

Austria	Israel	Spain
Belgium	Italy	Sweden
Egypt, Arab Rep. of	Netherlands	Switzerland
France	New Zealand	Thailand
Germany	Norway	Turkey
Hungary	Portugal	United Kingdom
India	Romania	U.S.S.R.
Ireland	South Africa, Rep. of	

The Member Bodies of the following countries had expressed disapproval of the document on technical grounds :

Australia
Czechoslovakia
Japan
U.S.A.

End-suction centrifugal pumps (rating 16 bar) – Designation, nominal duty point and dimensions

1 SCOPE AND FIELD OF APPLICATION¹⁾

This International Standard specifies the principal dimensions and nominal duty point of end-suction centrifugal pumps having a maximum operating rating of 16 bar.²⁾

2 REFERENCES

ISO/R 228, *Pipe threads where pressure-tight joints are not made on the threads (1/8 inch to 6 inches).*

ISO 496, *Driving and driven machines – Shaft heights.*

ISO/R 775, *Cylindrical and 1/10 conical shaft ends.*

ISO 3069, *End-suction centrifugal pumps – Dimensions of cavities for mechanical seals and for soft packing.* (Supplement to this International Standard.)

NOTE – ISO 2084 can be used for the dimensions of flanges.

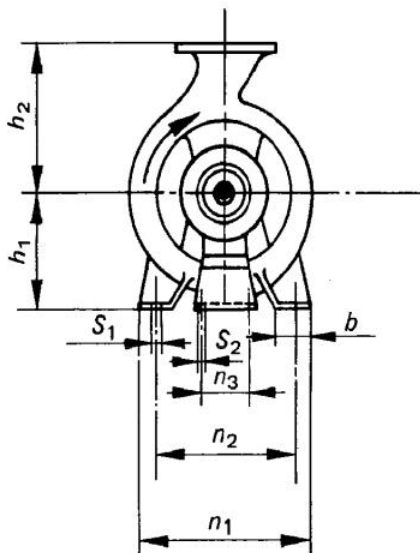

NOTE – Tapping points

All connections shall be in accordance with ISO/R 228.

A : Connection for cooling or heating supply to be 3/8 in.

B : Stuffing box tapping points to be as large as possible but not to exceed 1/2 in.

3 DESIGNATION

The pump designation comprises three numbers : the first corresponds to the inlet diameter, the second to the outlet diameter and the third to the nominal diameter of the impeller.

Example of designation

A centrifugal pump with an inlet diameter of 80 mm, an outlet diameter of 50 mm and a nominal impeller diameter of 250 mm is designated 80-50-250.

4 NOMINAL DUTY POINT AND DIMENSIONS

See figure below and table on page 2.

5 STATIC TEST PRESSURE

Static test pressure shall be 1,5 times the maximum discharge pressure but shall not exceed 24 bar. The relation between cold test pressure and hot operating pressure shall be the subject of agreement between manufacturer and user.

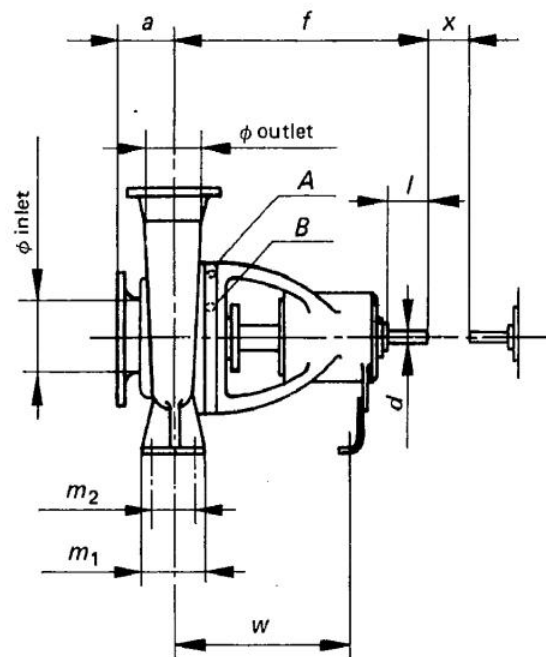

1) The manufacturer shall be consulted about the temperature limitation.

2) 1 bar = 0,1 MPa.

TABLE – Nominal duty point and dimensions

Size designation ²⁾			Nominal duty point				Dimensions in millimetres																							
φ inlet mm	φ outlet mm	φ impeller (nom- inal) mm	n 1 450 min ⁻¹		n 2 900 min ⁻¹		Pump				Support					Clearance holes for bolts		Shaft end												
			Q m ³ /h	H m	Q m ³ /h	H m	a	f	h ₁	h ₂	b	m ₁	m ₂	n ₁	n ₂	n ₃	w	S ₁	S ₂	d	l	x ¹⁾								
50	32	125	6,3	5	12,5	20	80	385	112	140	50	100	70	190	140	110	285	M 12	M 12	24	50	100								
50	32	160		8		32			132	160				240	190															
50	32	200		12,5		50			160	180				320	250															
50	32	250		20		80			100	500				180	225								65	125	95	320	250	370	32	80
65	50 (40) ³⁾	125	12,5	5	25	20	80	385	112	140	50	100	70	210	160	110	285	M 12	M 12	24	50	100								
65	50 (40) ³⁾	160		8		32			132	160				240	190															
65	40	200		12,5		50			100	160				180	265								212	320	250					
65	40	250		20		80			180	225				320	250								65	125	95	345	280	370	32	80
65	40	315		32		125			125	500				200	250								65	125	95	345	280	370	32	80
80	65 (50) ³⁾	125	25	5	50	20	100	385	132	160	50	100	70	240	190	110	285	M 12	M 12	24	50	100								
80	65 (50) ³⁾	160		8		32			160	180				265	212															
80	50	200		12,5		50			100	180				225	320								250							
80	50	250		20		80			125	500				225	280								65	125	95	345	280	370	32	80
80	50	315		32		125			125	500				225	280								65	125	95	345	280	370	32	80
100	80 (65) ³⁾	125	50	5	100	20	100	385	160	180	65	125	95	280	212	110	285	M 12	M 12	24	50	100								
100	80 (65) ³⁾	160		8		32			200	225				320	250															
100	65	200		12,5		50			500	180				225	360								280							
100	65	250		20		80			125	530				225	280								80	160	120	400	315	370	42	110
100	65	315		32		125			125	530				225	280								80	160	120	400	315	370	42	110
125	80	160	80	8	160	32	125	500	180	225	65	125	95	320	250	110	370	M 12	M 12	32	80	140								
125	80	200		12,5		50			250	315				400	315															
125	80	250		20		80			530	280				355	435								355							
125	80	315		32		125			530	280				355	435								355							
125	80	400		50		160			120	400				315	435								355							
125	100	200	100 ⁴⁾	12,5	200 ⁴⁾	50	125	500	200	280	80	160	120	360	280	110	370	M 16	M 12	42	110	140								
125	100	250		20		80			225	315				400	315															
125	100	315		32		125			140	530				250	315								100	200	150	500	400	370	42	110
125	100	400		50		160			120	400				315	435								355							
150	125	250	200	20	315 ⁴⁾	140	530	280	250	355	100	200	150	400	315	110	370	M 16	M 12	42	110	140								
150	125	315		32					125	315				400	435								355							
150	125	400		50					160	120				400	315								435	355						
200	150	250	315 ⁴⁾	20	400	160	530	280	375	450	100	200	150	500	400	110	370	M 20	M 12	42	110	180								
200	150	315		32					125	400				450																
200	150	400		50					160	120				400	450															

optional

NOTES

- a) The forms and dimensions not specified are left to the discretion of the manufacturer.
- b) Rotation is clockwise when viewed from the driven end.
- 1) Gap necessary for the withdrawal of the rotor toward the driven side.
- 2) Flange rating 16 bar.
- 3) Branch sizes in brackets to be valid for a limited period only.
- 4) These two values are alternatives.